



INDUSTRIAL Carbide Tipped **Saw Blades**

- ✓ Large European style micrograin carbide tips
- ✓ Laser-cut expansion slots to assure plate stability
- ✓ Unique technology for perfect straightening, balancing and tensioning
- ✓ H7 concentric bore enables tight fit to eliminate both circular run-out and vibration
- ✓ Copper plugs to reduce turbulent noise and vibration
- ✓ Large gullets for improved chip clearance

 **ELECTROBLU™**
ECO-Friendly Non-Stick Coating

- ✓ Reduces resin accumulation and heat build-up
- ✓ Tips stay sharper longer resulting in extended blade life
- ✓ Applied by using an electrostatic bonding process

⚠ Warning: Before use, read saw blade safety guidelines on pages 312-314.



PRESTIGE™

18° Hook Alternate Top Bevel (ATB) Grind

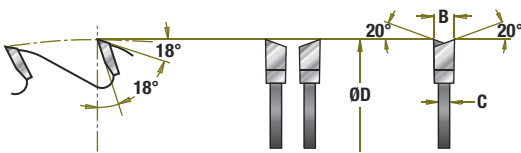

The Amana Tool® Prestige™ general purpose blade cuts smoother and stays sharper longer in solid wood, plywood, MDF and chipboard. It features a massive tool-steel plate (.102" thick!) with expansion slots and copper plugs that practically eliminate vibration. The 40 teeth are ground with a steep 20° bevel angle, alternating left and right, for crisp, clean cuts both across grain and with the grain. The 18° hook angle yields an effortless feed. The precision-ground carbide teeth are individually computer-verified to have minimal run-out.



- Massive (.102" thick!) tool-steel plate with copper plugs that practically eliminates vibration.
- Precision-ground carbide teeth (20° ATB, hook) are individually computer verified for run-out of less than 1/10,000" on all axis.

Prestige™ Rated "EXCELLENT" for

- ✓ Ripping solid wood
- ✓ Crosscutting solid wood
- ✓ Ripping plywood
- ✓ Crosscutting plywood



ØD		Teeth	Grind	'B' Kerf Inch	'C' Plate Inch	Bore	Tool No.
Inch	mm						
10	250	40	ATB	.134	.102	5/8	PR1040
10	250	40	ATB	.134	.102	5/8	PR1040C *
12	300	40	ATB	.134	.102	1	PR1240

* Electro Blu™ Non-Stick Coating.

'EURO-RIP' RIPPING

With Cooling Slots and Anti-Kickback Feature

20° Hook • Flat Top (FT) Grind

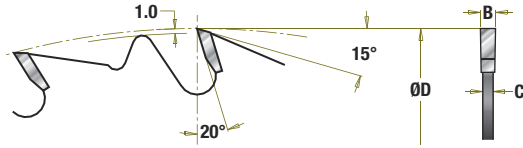

Soft/Hardwood Ripping

Designed for ripping hardwood and softwood, this exceptional blade cuts fast and smooth. The flat-top grind and the high positive hook angle reduce feed effort. The anti-kickback limits the thickness of chip; taken to offer a safer cut. Cooling slots in the body prevent excessive heat build-up.

ØD		Teeth	Grind	'B' Kerf	'C' Plate	Bore	*P.H.	Tool No.
Inch	mm							
10	250	20	FT	.126	.087	5/8	—	RB1020
10	250	20	FT	.126	.087	5/8	—	RB1020C*
10	250	20	FT	.126	.087	30mm	2/7/42, 2/9/46 & 2/10/60	RB1020-30
12	300	24	FT	.126	.087	1	—	RB1224
12	300	24	FT	.126	.087	30mm	2/7/42, 2/9/46 & 2/10/60	RB1224-30
14	350	28	FT	.126	.087	1	—	RB1428
14	350	28	FT	.126	.087	30mm	2/7/42, 2/9/46 & 2/10/60	RB1428-30
16	400	28	FT	.137	.098	1	—	RB1628

* Electro Blu™ Non-Stick Coating.

RIPPING STANDARD

18° to 20° Hook • Flat Top (FT) Grind

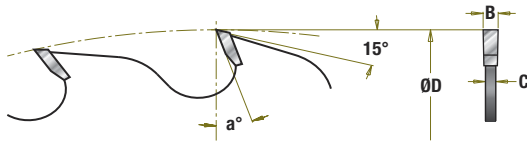

Soft/Hardwood Ripping

This blade is the classic ripper for both hardwood and softwood. It features the flat-top grind for cutting with the grain efficiently; ample gullets for fast chip-clearance; expansion slots and turbulence-reducing copper plugs. Available in 18° and 20° hook configurations. The blade with the 20° hook angle features a thicker plate and cuts a wider kerf. Use in single and gang-rip saws.

ØD		Teeth	Grind	a°	'B' Kerf	'C' Plate	Bore	*P.H.	Tool No.
Inch	mm								
10	250	24	FT	20°	.142	.095	5/8	—	610240
12	300	30	FT	20°	.160	.110	1	—	612300
12	300	30	FT	20°	.173	.110	30mm	2/7/42, 2/9/46 & 2/10/60	612300-30
16	400	36	FT	20°	.173	.118	30mm	2/7/42, 2/9/46 & 2/10/60	616360-30
18	450	32	FT	20°	.157	.110	1	—	618320
20	500	36	FT	20°	.173	.110	1	—	620360

ØD		Teeth	Grind	a°	'B' Kerf	'C' Plate	Bore	*P.H.	Tool No.
Inch	mm								
10	250	20	FT	18°	.126	.087	5/8	—	610200
12	300	24	FT	18°	.126	.087	1	—	612240
12	300	24	FT	18°	.126	.087	30mm	2/7/42, 2/9/46 & 2/10/60	612240-30
14	350	28	FT	18°	.137	.098	1	—	614280
16	400	32	FT	18°	.137	.098	1	—	616320
16	400	32	FT	18°	.137	.098	30mm	2/7/42, 2/9/46 & 2/10/60	616320-30

* P.H. = pin-hole configuration. Example: 2/10/60 = 2 @ 10mm dia. on 60mm circle.

▲ **Warning:** Before use, read saw blade safety guidelines on pages 312-314.

RIPPING HEAVY-DUTY

18° Hook • Flat Top (FT) Grind

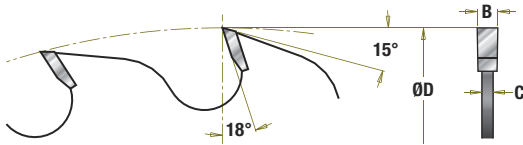

Heavy-duty production ripping is this blade's forte. It has all the features needed for use with power feeders and gang-ripping operations: a low tooth count, flat-top grind, deep gullets for efficient chip clearance and a thick plate for reduced vibration.



Soft/Hardwood Ripping

ØD		Teeth	Grind	'B' Kerf Inch	'C' Plate Inch	Bore	*P.H.	Tool No.
Inch	mm							
10	250	20	FT	.150	.095	5/8	—	710200
12	300	24	FT	.173	.110	1	—	712240
14	350	28	FT	.173	.110	1	—	714280
14	350	28	FT	.173	.110	30mm	2/7/42, 2/9/46 & 2/10/60	714280-30
16	400	32	FT	.173	.118	1	—	716320
16	400	32	FT	.173	.118	30mm	2/7/42, 2/9/46 & 2/10/60	716320-30

GLUE LINE RIPPING

22° Hook • Triple Chip (TC) Grind

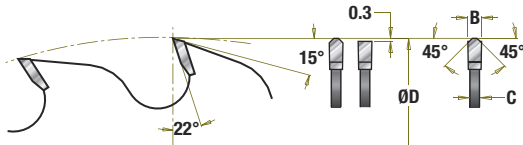

Rip then glue up. With this exceptional blade, there's no need for sanding or jointing after the cut. The precision triple-chip grind and extra-high hook angle allow aggressive feed rates, yet produces an extra-smooth cut finish. The thick plate minimizes vibration.

Use on table saws, sliding table saw, single and gang-rip operations.



Soft/Hardwood Ripping

ØD		Teeth	Grind	'B' Kerf Inch	'C' Plate Inch	Bore	Machine	Tool No.
Inch	mm							
10	250	30	TCG	.145	.095	5/8	—	610301
12	300	40	TCG	.160	.110	1	—	612401
12	300	40	TCG	.160	.110	70mm	SCM	612401-70 △
14	350	40	TCG	.169	.118	1	—	614401

△ 2 Keyways (20mm Centers x 5mm Dia.)

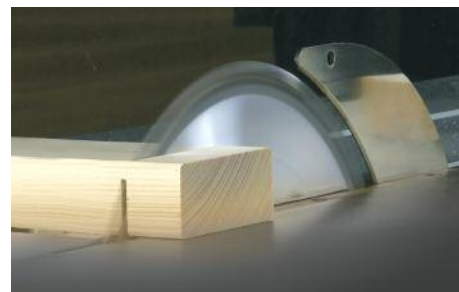

MULTI-USE RIPPING/GENERAL PURPOSE

15° Hook • Alternate Top Bevel (ATB) Grind

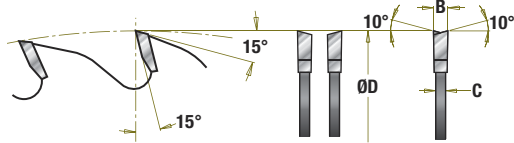

This is an excellent and popular general purpose configuration blade. Its low tooth count, high hook angle, and ample gullets make it an aggressive, fast-cutting ripping blade. But its ATB grind allows it to crosscut well. A good choice for all-around use.



ØD		Teeth	Grind	'B' Kerf	'C' Plate	Bore	*P.H.	Tool No.
Inch	mm							
10	250	30	ATB	.126	.087	5/8	—	610300
10	250	30	ATB	.126	.087	30mm	2/7/42, 2/9/46 & 2/10/60	610300-30
12	300	36	ATB	.126	.087	1	—	612360
12	300	36	ATB	.126	.087	30mm	2/7/42, 2/9/46 & 2/10/60	612360-30
14	350	42	ATB	.137	.098	1	—	614420
14	350	42	ATB	.137	.098	30mm	2/7/42, 2/9/46 & 2/10/60	614420-30
16	400	48	ATB	.137	.098	1	—	616480
16	400	48	ATB	.137	.098	30mm	2/7/42, 2/9/46 & 2/10/60	616480-30
18	450	54	ATB	.150	.110	1	—	618540
20	500	60	ATB	.173	.110	1	—	620600

GENERAL PURPOSE CUT-OFF

15° Hook • Alternate Top Bevel (ATB) Grind

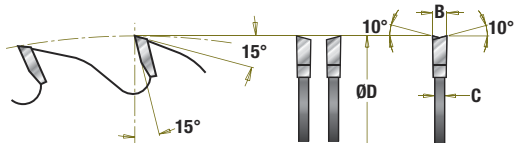

While similar in most aspects to the blade above, this one has a slightly lower hook angle. That lower angle improves the surface quality of the cut while increasing the feed pressure required. This blade is a good choice for general purpose ripping and crosscutting of hardwoods and softwoods in a range of thicknesses, with occasional cutting of plywood and other man-made materials mixed in.



ØD		Teeth	Grind	'B' Kerf	'C' Plate	Bore	*P.H.	Tool No.
Inch	mm							
8	200	34	ATB	.118	.079	5/8	—	683400
—	220	34	ATB	.118	.079	30mm	2/7/42	220T340†
9	230	24	ATB	.118	.079	5/8	—	692400
9	230	40	ATB	.118	.079	5/8	—	694000
10	250	40	ATB	.126	.087	5/8	—	610400
10	250	40	ATB	.126	.087	30mm	2/7/42, 2/9/46 & 2/10/60	610400-30
12	300	48	ATB	.126	.087	1	—	612480
12	300	48	ATB	.126	.087	30mm	2/7/42, 2/9/46 & 2/10/60	612480-30
14	350	54	ATB	.137	.098	1	—	614540
14	350	54	ATB	.137	.098	30mm	2/7/42, 2/9/46 & 2/10/60	614540-30
16	400	60	ATB	.137	.098	1	—	616600
16	400	60	ATB	.137	.098	30mm	2/7/42, 2/9/46 & 2/10/60	616600-30

† For Holz-Her® 220mm panel saws.

* P.H. = pin-hole configuration. Example: 2/10/60 = 2 @ 10mm dia. on 60mm circle.

▲ Warning: Before use, read saw blade safety guidelines on pages 312-314.

THIN KERF GENERAL PURPOSE

15° Hook • Alternate Top Bevel (ATB) Grind

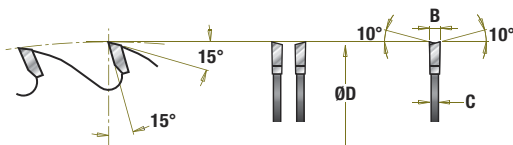

A thin-kerf blade has a slightly thinner plate and cutting tips. The benefits include reduced stress on the saw and its motor and reduced stock loss. Thin-kerf blades typically are used on saws powered by universal motors, including jobsite table saws and the various types of miter saws.

Not recommended for cutting stock thicker than 3/4" unless stabilizer(s) are used.



**THIN
KERF**



Soft/Hardwood Crosscut Combination Rip/Crosscut

ØD		Teeth	Grind	'B' Kerf	'C' Plate	Bore	Tool No.
Inch	mm						
8	200	34	ATB	.090	.062	5/8	TB83400
10	250	40	ATB	.090	.062	5/8	TB10400
12	300	48	ATB	.090	.062	1	TB12480
14	350	54	ATB	.090	.062	1	TB14540

COMBINATION RIPPING & CROSSCUT

15° Hook • Combination Grind 4 ATB & 1 Raker

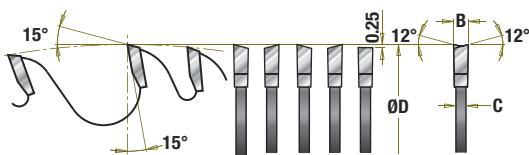

Where one blade must do almost everything – ripping and crosscutting hardwood and softwood, cutting plywood – this blade is a good choice. It is in the traditional combination-blade configuration, with a flat-top tooth and 4 alternate top bevel teeth in groupings of five. The large gullets at the raker tooth allow deep cuts with improved chip ejection.



Combination Rip/Crosscut

ØD		Teeth	Grind	'B' Kerf	'C' Plate	Bore	Tool No.
Inch	mm						
8	200	40	4 & 1	.126	.087	5/8	684004
9	230	40	4 & 1	.126	.087	5/8	694004
10	250	50	4 & 1	.135	.095	5/8	610504
10	250	50	4 & 1	.135	.095	5/8	610504C*
12	300	60	4 & 1	.150	.110	1	612604
14	350	70	4 & 1	.150	.110	1	614704
16	400	80	4 & 1	.158	.118	1	616804

* Electro Blu™ Non-Stick Coating.

CUT-OFF & CROSSCUT

10° Hook • Alternate Top Bevel (ATB) Grind

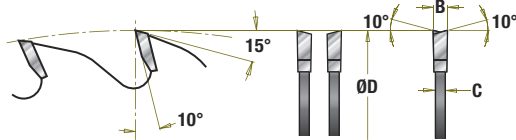

As our standard cut-off and crosscut blade, this is ideal for table saws and sliding table saws. Its combination of 10° hook and the alternate top bevel tooth grind provide good-quality cuts and a long cutting life.

Suitable for hardwood, softwood, even plywood and chipboard. Good choice for heavy production in any cabinet-making shop.



Soft/Hardwood Crosscut

ØD		Teeth	Grind	'B' Kerf	'C' Plate	Bore	*P.H.	Tool No.
Inch	mm							
8	200	48	ATB	.118	.079	5/8	—	684800
9	230	60	ATB	.118	.079	5/8	—	696000
10	250	60	ATB	.126	.087	5/8	—	610600
10	250	60	ATB	.126	.087	5/8	—	610600C*
10	250	60	ATB	.126	.087	30mm	2/7/42, 2/9/46 & 2/10/60	610600-30
12	300	60	ATB	.126	.087	1	—	612600
12	300	60	ATB	.126	.087	30mm	2/7/42, 2/9/46 & 2/10/60	612600-30
12	300	72	ATB	.126	.087	1	—	612720
12	300	72	ATB	.126	.087	1	—	612720C*
12	300	72	ATB	.126	.087	30mm	2/7/42, 2/9/46 & 2/10/60	612720-30 †
14	350	72	ATB	.137	.098	1	—	614720
14	350	72	ATB	.137	.098	30mm	2/7/42, 2/9/46 & 2/10/60	614720-30
14	350	84	ATB	.137	.098	1	—	614840
16	400	96	ATB	.137	.098	1	—	616960
18	450	108	ATB	.158	.110	1	—	618108
18	450	108	ATB	.158	.110	30mm	2/7/42, 2/9/46 & 2/10/60	618108-30
20	500	120	ATB	.173	.110	1	—	620120

† For Altendorf®, Omega, SCMI®, and Striebig® sliding table saws.

* Electro Blu™ Non-Stick Coating.

CUT-OFF & CROSSCUT HEAVY-DUTY

10° to 18° Hook • Alternate Top Bevel (ATB) Grind

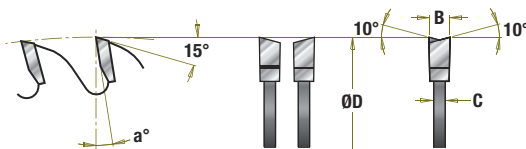

This is a heavy-duty production blade for general trimming and crosscutting of hardwood and softwood. It has an extra-thick plate and cuts a wide kerf. The hook angle is aggressive, varying from 10° to 18°, depending upon the tooth count and blade diameter. All blades feature the alternate top bevel grind for clean cuts.

Appropriate for use on table saws and radial arm saws.



Soft/Hardwood Crosscut

ØD		Teeth	Grind	a°	'B' Kerf	'C' Plate	Bore	Tool No.
Inch	mm							
12	300	96	ATB	10°	.173	.110	1	712960
16	400	60	ATB	18°	.173	.110	1	716600
16	400	96	ATB	10°	.173	.110	1	716960

* P.H. = pin-hole configuration. Example: 2/10/60 = 2 @ 10mm dia. on 60mm circle.

▲ Warning: Before use, read saw blade safety guidelines on pages 312-314.

CUT-OFF & CROSSCUT HEAVY-DUTY

10° to 18° Hook • Triple Chip (TC) Grind

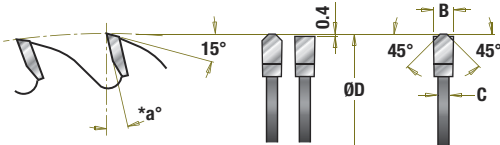

Heavy-duty production blade featuring increased thickness of plate and kerf and more aggressive hook angle. Good for cutting plastic laminated materials, composition board and plywood.



Plastic Laminate
Single & Double Sided



MDF/Fiberboard

ØD		Teeth	Grind	a°	'B' Kerf	'C' Plate	Bore	Tool No.
Inch	mm							
12	300	60	TCG	15°	.173	.095	1	712601
12	300	96	TCG	10°	.173	.098	1	712961
14	350	72	TCG	15°	.173	.110	1	714721
16	400	80	TCG	10°	.173	.118	1	716801
16	400	96	TCG	18°	.173	.118	1	716961

FINE CUT-OFF & CROSSCUT

10° Hook • Triple Chip (TC) Grind

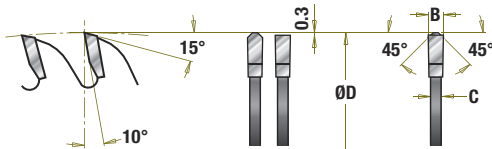

This blade is ideal for cutting materials with fragile surface layers, like veneers and laminates. High tooth counts yield smooth finishes. The 10° hook angle provides effortless feeding. The triple-chip tooth opens a narrow kerf, and the raker widens it.



Plastic Laminate
Single & Double Sided



MDF/Fiberboard

ØD		Teeth	Grind	'B' Kerf	'C' Plate	Bore	*P.H.	Tool No.
Inch	mm							
8	200	64	TCG	.118	.079	5/8	—	686401
8	200	64	TCG	.118	.079	30mm	—	686401-30
—	220	64	TCG	.118	.079	30mm	2/7/42	220T641 †
10	250	80	TCG	.126	.087	5/8	—	610801
10	250	80	TCG	.126	.087	5/8	—	610801C*
10	250	80	TCG	.126	.087	30mm	2/7/42, 2/9/46 & 2/10/60	610801-30
12	300	96	TCG	.126	.087	1	—	612961
12	300	96	TCG	.126	.087	30mm	2/7/42, 2/9/46 & 2/10/60	612961-30
14	350	108	TCG	.137	.098	1	—	614109
14	350	108	TCG	.137	.098	30mm	2/7/42, 2/9/46 & 2/10/60	614109-30
16	400	120	TCG	.137	.098	1	—	616129
18	450	132	TCG	.157	.110	1	—	618133

† For Holz-Her® 220mm Panel Saws.

* Electro Blu™ Non-Stick Coating.

DITEC™ EXTENDED TRIMMING FOR MDF

0° Hook • Triple Chip (TC) Grind

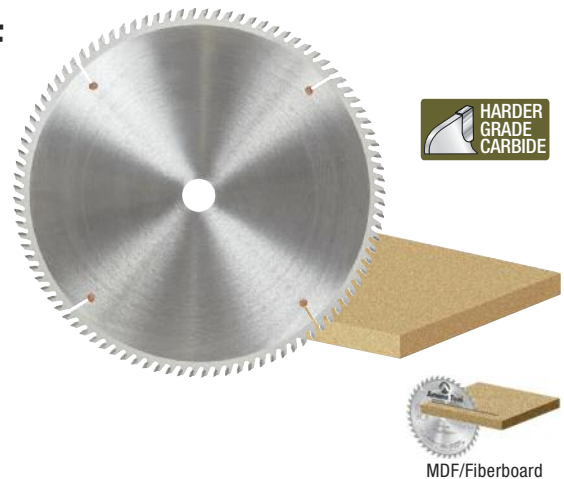
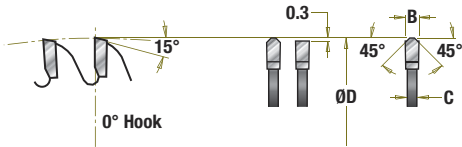

HARDER GRADE CARBIDE

MDF/Fiberboard

If you cut MDF on a regular basis, this is the blade you should use. It has the same features as our Fine Crosscut blades such as a thicker than standard plate, high tooth count, and the TCG grind, but this blade has the long-lasting DITEC™ carbide tips.

In addition, this blade cuts hard and abrasive composite materials such as: **carbon fiber**, **Trespa®**, etc.

ØD		Teeth	Grind	'B' Kerf	'C' Plate	Bore	Tool No.
Inch	mm						
12	300	96	TCG	.126	.094	1	DT12962
14	350	84	TCG	.130	.098	1	DT14842

GENERAL PURPOSE CUT-OFF

10° Hook • Triple Chip (TC) Grind

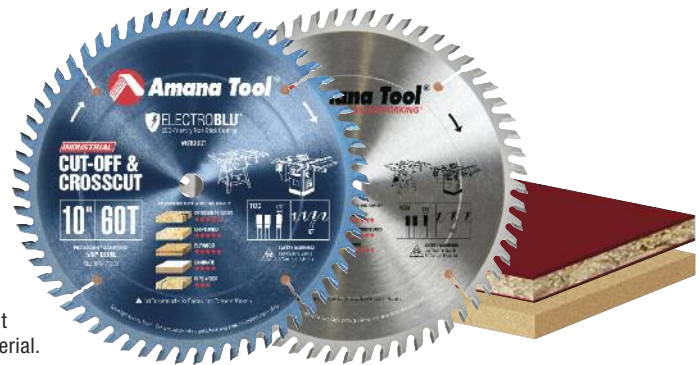
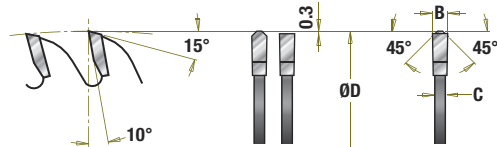

Plastic Laminate
Single & Double Sided

MDF/Fiberboard

While this blade handles general trimming and crosscutting of hardwood and softwood, plywood and composition materials, it excels at cutting single or double-sided plastic-laminated material. It leaves a smooth, clean, chip-free finish on the top and bottom edges. The blades in this series feature a high tooth count, the triple-chip grind and a 10° hook angle for a successful compromise between feed effort and cut finish.

ØD		Teeth	Grind	'B' Kerf	'C' Plate	Bore	*P.H.	Tool No.
Inch	mm							
8	200	48	TCG	.118	.079	5/8	—	684801
9	230	40	TCG	.118	.079	5/8	—	694001 ••
10	250	60	TCG	.126	.087	5/8	—	610601
10	250	60	TCG	.126	.087	5/8	—	610601C*
10	250	60	TCG	.126	.087	30mm	2/7/42, 2/9/46 & 2/10/60	610601-30
12	300	60	TCG	.126	.087	1	—	612601
12	300	60	TCG	.126	.087	30mm	2/7/42, 2/9/46 & 2/10/60	612601-30
12	300	72	TCG	.126	.087	1	—	612721
12	300	72	TCG	.126	.087	1	—	612721C*
12	300	72	TCG	.126	.087	30mm	2/7/42, 2/9/46 & 2/10/60	612721-30 †
12	300	72	TCG	.126	.087	30mm	2/7/42, 2/9/46 & 2/10/60	612721-30C†* New
14	350	54	TCG	.137	.106	1	—	614541
14	350	72	TCG	.137	.098	1	—	614721
14	350	72	TCG	.137	.098	30mm	2/7/42, 2/9/46 & 2/10/60	614721-30
14	350	84	TCG	.137	.098	1	—	614841
16	400	96	TCG	.137	.098	1	—	616961
18	450	108	TCG	.158	.110	1	—	618109
18	450	108	TCG	.158	.110	30mm	2/7/42, 2/9/46 & 2/10/60	618109-30
20	500	120	TCG	.173	.110	1	—	620121

•• 15° Hook Angle (Tool # 694001 Only)

† For Altendorf®, Omega, SCMI®, and Striebig® sliding table saws.

* Electro Blu™ Non-Stick Coating.

* P.H. = pin-hole configuration. Example: 2/10/60 = 2 @ 10mm dia. on 60mm circle.

▲ **Warning:** Before use, read saw blade safety guidelines on pages 312-314.

TRIM

10° Hook • Alternate Top Bevel (ATB) Grind

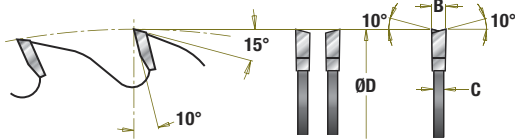

Our trim blade, suitable for use on table saws, sliding table saws, radial arms, and miter saws of all types, leaves a super-smooth finish when cutting hard or softwood. It is especially suited to trimming and sizing veneers and laminates in single sheets or in stacks. The alternate top grind and high tooth counts produce excellent, chip-free cuts. The 10° hook angle provides effortless feeding.



ØD		Teeth	Grind	'B' Kerf Inch	'C' Plate Inch	Bore	*P.H.	Tool No.
Inch	mm							
7	180	58	ATB	.118	.079	5/8	—	675600
8	200	64	ATB	.118	.079	5/8	—	686400
—	220	64	ATB	.118	.079	30mm	2/7/42	220T640+
10	250	80	ATB	.126	.087	5/8	—	610800
10	250	80	ATB	.126	.087	5/8	—	610800C*
10	250	80	ATB	.126	.087	30mm	2/7/42, 2/9/46 & 2/10/60	610800-30
12	300	96	ATB	.126	.087	1	—	612960
12	300	96	ATB	.126	.087	30mm	2/7/42, 2/9/46 & 2/10/60	612960-30
14	350	108	ATB	.137	.098	1	—	614108
14	350	108	ATB	.137	.098	30mm	2/7/42, 2/9/46 & 2/10/60	614108-30
16	400	120	ATB	.137	.098	1	—	616128
18	450	132	ATB	.157	.110	1	—	618132

+ For Holz-Her® 220mm Panel Saws.

* Electro Blu™ Non-Stick Coating.

THIN KERF TRIM

10° Hook • Alternate Top Bevel (ATB) and Triple Chip (TC) Grind

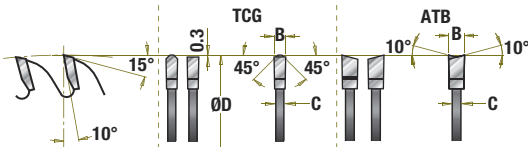

Thin-kerf blades require less power because they have thinner plates and narrower tips. This trim blade is ideal for jobsite table saws and various miter saws for that reason. Available in either alternate top bevel grind for cutting hardwood, softwood and plywood, or triple-chip grind for chipboard and laminate-covered material. Also suitable for cutting thin Plexiglas®, masonite and plastics.

Use of stabilizers is recommended when cutting stock over 3/4" thick.



ØD		Teeth	Grind	'B' Kerf Inch	'C' Plate Inch	Bore	Tool No.
Inch	mm						
8	200	64	ATB	.090	.062	5/8	TB86400
10	250	80	ATB	.090	.062	5/8	TB10800
10	250	100	ATB	.090	.062	5/8	TB10100
12	300	96	ATB	.090	.062	1	TB12960
14	350	108	ATB	.090	.062	1	TB14108
8	200	64	TCG	.090	.062	5/8	TB86401
10	250	80	TCG	.090	.062	5/8	TB10801
10	250	100	TCG	.090	.062	5/8	TB10101
12	300	96	TCG	.090	.062	1	TB12961

* P.H. = pin-hole configuration. Example: 2/10/60 = 2 @ 10mm dia. on 60mm circle.

⚠ Warning: Before use, read saw blade safety guidelines on pages 312-314.



THIN KERF FINE FINISHING

10° Hook • Alternate Top Bevel (ATB) Grind

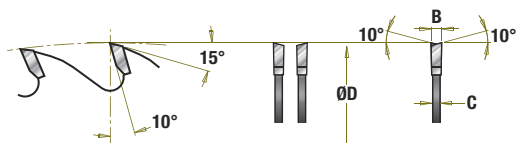

Thin kerf blades are designed for miter smooth cuts; less drag on bearings and brake and reduces stock loss on expensive woods and veneer plywoods. Not recommended to cut stock over 3/4" without the use of a stabilizer.



**THIN
KERF**

ØD		Teeth	Grind	'B' Kerf Inch	'C' Plate Inch	Bore	Tool No.
Inch	mm						
10	250	80	ATB	.090	.062	5/8	610800-TS
12	300	96	ATB	.090	.062	1	612960-TS
14	350	108	ATB	.090	.062	1	614108-TS
15	375	100	ATB	.104	.079	1	615100-TS

THIN KERF FINE FINISHING

10° Hook • Triple Chip (TC) Grind

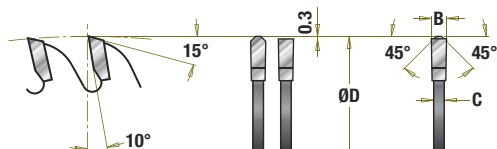

Thin kerf blades are designed for miter smooth cuts; less drag on bearings and brake and reduces stock loss on expensive woods and veneer plywoods. Not recommended to cut stock over 3/4" without the use of a stabilizer. TCG grind can also be used for cutting thin Plexiglas®, masonite and plastics.



**THIN
KERF**

ØD		Teeth	Grind	'B' Kerf Inch	'C' Plate Inch	Bore	Tool No.
Inch	mm						
10	250	80	TCG	.090	.062	5/8	610801-TS

*P.H. = pin-hole configuration. Example: 2/10/60 = 2 @ 10mm dia. on 60mm circle.

Warning: Before use, read saw blade safety guidelines on pages 312-314.

MITER/DOUBLE MITER

2° Negative Hook • 4 ATB & 1 Raker

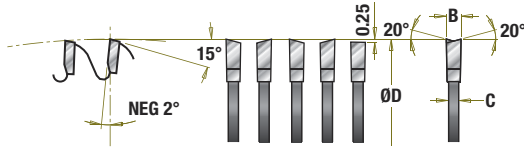

Designed especially for use on various styles of miter saws, as well as radial arm saws. This blade cuts crisp, chip-free miters in hardwood and softwood, in moldings and picture-frame stock. All these blades feature the alternate top bevel plus raker grind (4 ATB plus 1 raker), 2° negative hook angle, and a high tooth count to produce exactly what you want for tight miters – extremely smooth cuts.



Soft/Hardwood
Crosscut

Cabinet Plywood
Rip/Crosscut

ØD Inch	Teeth	Grind	'B' Kerf Inch	'C' Plate Inch	Bore	Machine Type	Tool No.
10	60	4&1	.115	.087	5/8	All Types	MS10600
12	100	4&1	.134	.110	5/8	Pistorius, CTD	MS12100-5/8
12	80	4&1	.122	.110	5/8	Pistorius, CTD	MS12800-5/8
12	80	4&1	.122	.110	1	Dewalt, Hitachi	MS12800
14	100	4&1	.150	.118	5/8	Pistorius, CTD	MS14100-5/8
14	100	4&1	.150	.118	1	Makita	MS14100
15	100	4&1	.118	.098	1	Hitachi	MS15100

Above blades are true "Imperial" sizes.

MITER/DOUBLE MITER

5° Negative Hook • California Triple Chip (C-TC) Grind

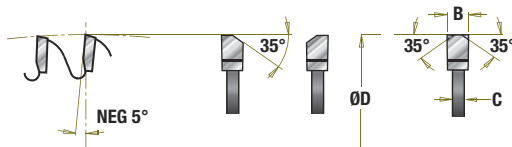

The California triple chip grind is the choice in the door and window manufacturing industry, and in framing shops everywhere. Its cuts are crisp and clean in wood, ACM (Aluminum Composite Materials) such as Alucobond®, Dibond®, Durabond etc., and burr-free in aluminum and other non-ferrous metals. This blade has a very high tooth count, a 5° negative hook, and a stout plate for smooth cuts and long tool life. It works in miter saws, compound miter saws, and sliding compound saws.



Soft/Hardwood Crosscut



Non-Ferrous Alloys

ØD Inch	Teeth	Grind	'B' Kerf Inch	'C' Plate Inch	Bore	Machine Type	Tool No.
10	96	C-TCG	.125	.100	5/8	Pistorius, CTD	CTC10963
12	90	C-TCG	.135	.110	5/8	Pistorius, CTD	CTC12903-5/8
12	108	C-TCG	.135	.110	1	Pistorius, CTD	CTC12108

Above blades are true "Imperial" sizes.

▲ WARNING: NEVER attempt to cut ferrous metals (steel, iron, etc.) with these saw blades. When cutting non-ferrous metals, a coolant or blade wax should be used and proper clamping devices employed.

HOLLOW GROUND

6° Negative Hook • Hollow Grind (HG)

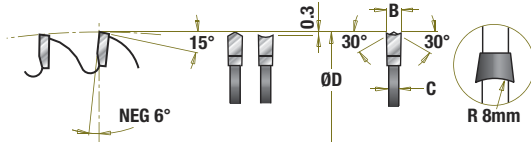

This specially designed saw blade makes exceptionally smooth cuts in melamine and other coated boards, without the need for scoring. The unique hollow grind, which pairs a triple-chip tooth with a raker tooth that's ground to a concave profile, produces crisp, clean cuts. The grind is commonly used in vertical panel saws, such as those made by Striebig® and Holz-Her®. The negative hook angle is particularly suitable for vertical panel saws.



Melamine
Single & Double Sided

ØD		Teeth	Grind	'B' Kerf Inch	'C' Plate Inch	Bore	*P.H.	Machines	Tool No.
Inch	mm								
—	220	42	HG	.126	.087	30mm	2/7/42	Holz-Her®	HG220T420 †
10	253	48	HG	.126	.087	5/8	—	—	HG10480
10	253	48	HG	.126	.087	30mm	2/7/42, 2/9/46 & 2/10/60	Holz-Her®	HG10480-30
12	303	60	HG	.126	.087	1	—	—	HG12600
12	305	60	HG	.126	.087	5/8	—	Pistorius	HG12600-5/8
12	303	60	HG	.126	.087	30mm	2/7/42, 2/9/46 & 2/10/60	Holz-Her®	HG12600-30

† For Holz-Her® 220mm panel saws.

HOLLOW GROUND

10° Positive Hook • Hollow Grind (HG)

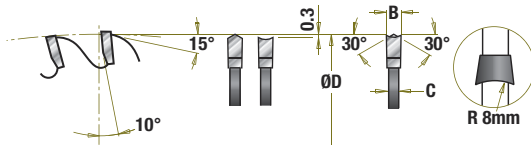

This specially designed saw blade makes exceptionally smooth cuts in melamine and other coated boards, without the need for scoring. The unique hollow grind, which pairs a triple-chip tooth with a raker tooth that's ground to a concave profile, produces crisp, clean cuts. The positive hook angle is particularly suitable for use on horizontal sliding table saws such as those made by Striebig®, Altendorf®, SCM and Holz-Her®.



Melamine
Single & Double Sided

ØD		Teeth	Grind	'B' Kerf Inch	'C' Plate Inch	Bore	*P.H.	Tool No.
Inch	mm							
10	253	48	HG	.126	.087	30mm	2/7/42, 2/9/46 & 2/10/60	HG10483-30
12	303	60	HG	.126	.087	30mm	2/7/42, 2/9/46 & 2/10/60	HG12603-30

* P.H. = pin-hole configuration. Example: 2/10/60 = 2 @ 10mm dia. on 60mm circle.

▲ Warning: Before use, read saw blade safety guidelines on pages 312-314.



DOUBLE-FACE MELAMINE & LAMINATE

6° Negative Hook • 25° 'High-ATB' Grind

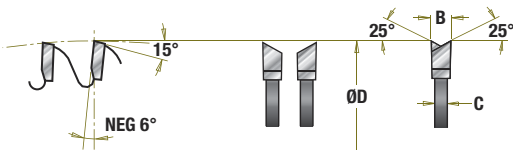

Designed specifically to cut melamine, this blade does just that without chipping on the top or bottom edges. (Your table saw must be properly tuned, of course.)

The special "High-ATB" grind (with 25° bevels) slices cleanly through fragile surface coatings like melamine and laminate. Coupled with a thick, heavy-duty plate for added stability, this blade produces extremely smooth cuts. It is easily resharpened.

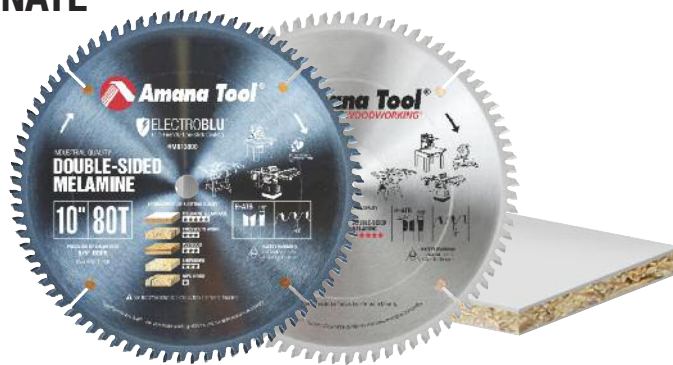

ØD		Teeth	Grind	'B' Kerf	'C' Plate	Bore	*P.H.	Tool No.
Inch	mm							
8	200	64	H-ATB	.110	.087	5/8	—	MB86400
—	220	42	H-ATB	.110	.087	30mm	2/7/42	MB220T420 †
10	250	80	H-ATB	.126	.102	5/8	—	MB10800
10	250	80	H-ATB	.126	.102	5/8	—	MB10800C*
10	250	80	H-ATB	.126	.102	30mm	2/7/42, 2/9/46 & 2/10/60	MB10800-30
12	300	96	H-ATB	.126	.102	1	—	MB12960
12	300	96	H-ATB	.126	.102	1	—	MB12960C*
12	300	96	H-ATB	.126	.102	30mm	2/7/42, 2/9/46 & 2/10/60	MB12960-30
14	350	108	H-ATB	.126	.102	1	—	MB14108
14	350	108	H-ATB	.126	.102	30mm	2/7/42, 2/9/46 & 2/10/60	MB14108-30
16	400	120	H-ATB	.150	.126	1	—	MB16120

Note: The 8" blade can be used on vertical type panel saws, such as 'Safety Speed Cut', etc.

† For 220mm Holz-Her® Panel Saws.

* Electro Blu™ Non-Stick Coating.

* P.H. denotes pin-hole configuration, if applicable.

Example: 2/10/60 = 2 @ 10mm dia. on 60mm circle.

▲ **Warning:** Before use, read saw blade safety guidelines on pages 312-314.

DOUBLE-FACE MELAMINE, KORTON & VENEERS

2° Negative Hook • 35° 'High-ATB' Grind

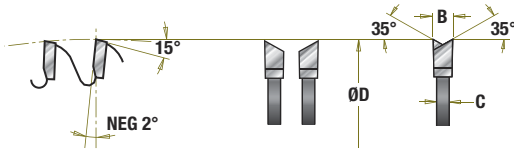

Alterations to the geometry and plate thickness provide improved results in certain melamine boards. The bevel angle of the ATB grind is far more acute (35°), and the plate is thinner than our standard melamine blades as seen on the previous page.

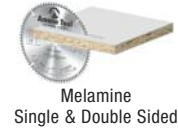

Melamine
Single & Double Sided

ØD		Teeth	Grind	'B' Kerf	'C' Plate	Bore	*P.H.	Tool No.
Inch	mm							
10	250	80	H-ATB	.118	.087	5/8	—	MSB1080
10	250	80	H-ATB	.118	.087	5/8	—	MSB1080C *
10	250	80	H-ATB	.118	.087	30mm	2/7/42, 2/9/46 & 2/10/60	MSB1080-30
12	300	96	H-ATB	.118	.087	1	—	MSB1296
12	300	96	H-ATB	.118	.087	30mm	2/7/42, 2/9/46 & 2/10/60	MSB1296-30

* Electro Blu™ Non-Stick Coating.

SOLID SURFACE

0° Hook • Modified Triple Chip (MTC) Grind

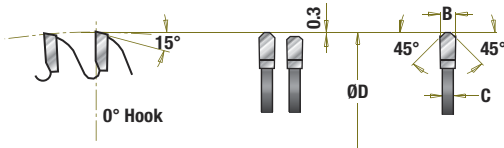

This blade is designed for cutting plastic laminate, Plexiglas®, and solid surface materials such as Dupont Corian®, Wilsonart®, Gibraltar® & Fountainhead®. The triple chip grind is especially configured to leave a swirl-free cut in solid surface materials. Thick, stable plate reduces vibration that degrades the cut and shortens tool life. The blade is suitable for a variety of saw configurations. The 0° hook angle virtually eliminates self-feeding when used with a radial arm saw.



Solid Surface



Plastic Laminate
Single & Double Sided

ØD		Teeth	Grind	'B' Kerf	'C' Plate	Bore	*P.H.	Tool No.
Inch	mm							
10	250	72	MTC	.126	.095	5/8	—	610721
10	250	72	MTC	.126	.095	5/8	—	610721C *
10	250	72	MTC	.126	.095	30mm	2/7/42, 2/9/46 & 2/10/60	610721-30
12	300	84	MTC	.126	.095	1	—	612841
12	300	84	MTC	.126	.095	30mm	2/7/42, 2/9/46 & 2/10/60	612841-30
14	350	96	MTC	.126	.102	1	—	614961
16	400	108	MTC	.126	.102	1	—	616109

* Electro Blu™ Non-Stick Coating.

* P.H. denotes pin-hole configuration, if applicable.

Example: 2/10/60 = 2 @ 10mm dia. on 60mm circle.

Warning: Before use, read saw blade safety guidelines on pages 312-314.

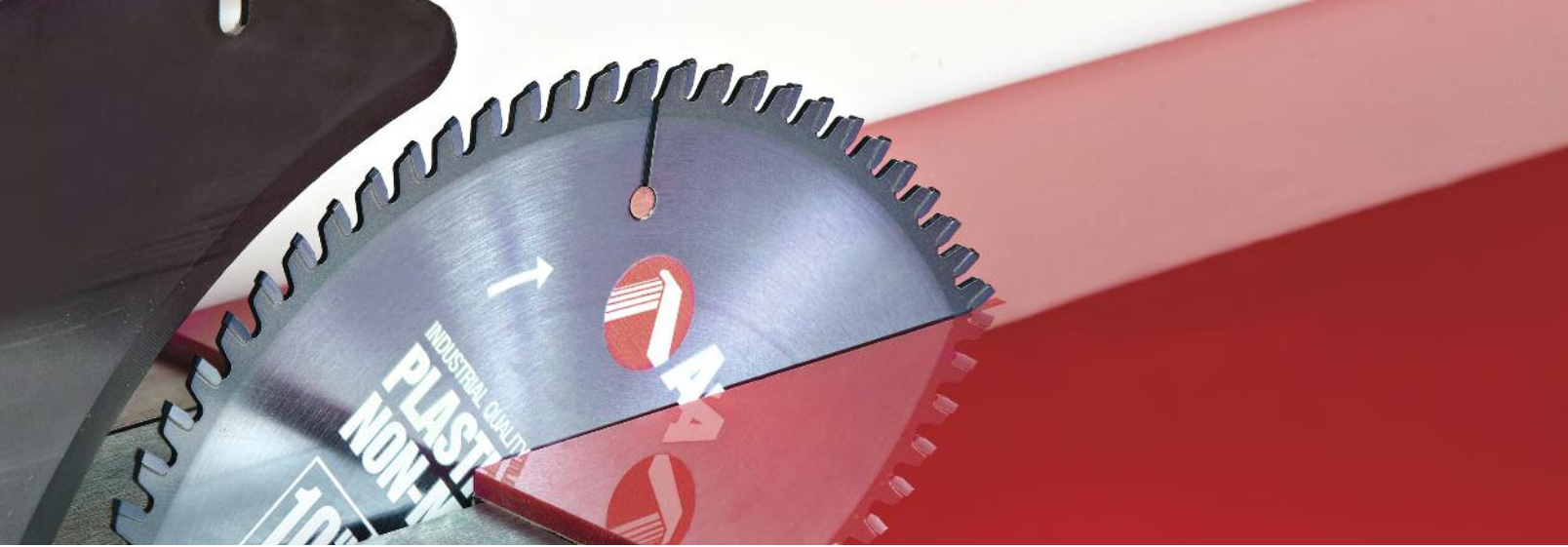

NON-MELT

2° Negative Hook • Modified Triple Chip (MTC) Grind

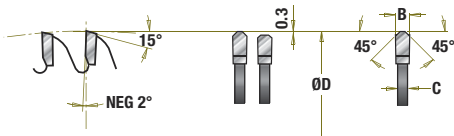

When cutting acrylics and plastics, “chip-welding” – a melting of the material – is a concern. But not with these Non-Melt blades. With a modified triple-chip grind and a 2° negative hook angle, they produce less heat than a standard blade, leaving a crisp and smooth edge in acrylic sheets, corrugated polypropylene, HDPE, Lexan® Plexiglas® polycarbonates, Teflon® Coroplast® High Impact Polystyrene (HIPS), Low Density Polyethylene (LDPE), Thermoplastic Polyolefin (TPO), Polyethylene Terephthalate Glycol (PETG) and other plastics.



Acrylic & Non-Melt Plastic

ØD		Teeth	Grind	'B' Kerf	'C' Plate	Bore	*P.H.	Tool No.
Inch	mm			Inch	Inch			
8	200	64	MTC	.098	.070	5/8	—	LB86401
8	200	64	MTC	.098	.070	5/8	—	LB86401C* <i>New</i>
—	220	64	MTC	.126	.079	30mm	2/7/42	LB220T641 †
10	250	80	MTC	.100	.070	5/8	—	LB10801
10	250	80	MTC	.100	.070	5/8	—	LB10801C*
10	250	80	MTC	.100	.070	30mm	2/7/42, 2/9/46 & 2/10/60	LB10801-30
12	300	96	MTC	.125	.102	1	—	LB12961
12	300	96	MTC	.125	.102	30mm	2/7/42, 2/9/46 & 2/10/60	LB12961-30
14	350	108	MTC	.145	.118	1	—	LB14108
16	400	120	MTC	.145	.118	1	—	LB16121

† For Holz-Her® 220mm panel saws.

* Electro Blu™ Non-Stick Coating.



* P.H. denotes pin-hole configuration, if applicable.

Example: 2/10/60 = 2 @ 10mm dia. on 60mm circle.

▲ **Warning:** Before use, read saw blade safety guidelines on pages 312-314.



NON-FERROUS METAL

6° Negative Hook • Triple Chip (TC) Grind

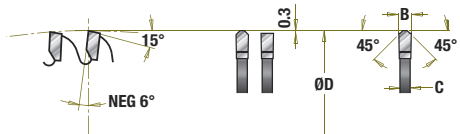

Ideal for cutting aluminum and non-ferrous metal bars such as copper, brass, bronze and lead. It also is good for cutting extrusions and profiles. The negative hook angle (-6°), triple-chip grind and thick plate combine to produce a superior finish. The blade can also be used to cut other “difficult” materials such as plastic, PVC tubing, fiberglass and ACM such as Alucobond®, Dibond® and Durabond®. Use a coolant or blade wax and clamp down the work-piece when cutting non-ferrous metals.



For Thick Aluminum (over 0.25")

ØD Inch	ØD mm	Teeth	Grind	'B' Kerf Inch	'C' Plate Inch	Bore	*P.H.	Tool No.
8	200	48	TCG	.110	.087	5/8	—	584801
10	250	60	TCG	.126	.102	5/8	—	510601
10	250	60	TCG	.126	.102	30mm	2/7/42, 2/9/46 & 2/10/60	510601-30
12	300	72	TCG	.126	.102	1	—	512721
12	300	72	TCG	.126	.102	30mm	2/7/42, 2/9/46 & 2/10/60	512721-30
14	350	84	TCG	.126	.102	1	—	514841
16	400	96	TCG	.150	.126	1	—	516961
18	450	108	TCG	.157	.134	1	—	518108

For Thin Material (under 0.25")

ØD Inch	ØD mm	Teeth	Grind	'B' Kerf Inch	'C' Plate Inch	Bore	*P.H.	Machines	Tool No.
7	180	58	TCG	.110	.087	5/8	—	—	575601
8	200	64	TCG	.110	.087	5/8	—	—	586401
9	230	60	TCG	.110	.087	5/8	—	—	596001
10	250	80	TCG	.126	.102	5/8	—	—	510801
10	250	80	TCG	.126	.102	5/8	—	—	510801C *
10	250	80	TCG	.126	.102	30mm	2/7/42, 2/9/46 & 2/10/60	—	510801-30
10	250	100	TCG	.126	.102	5/8	—	—	510101
12	300	96	TCG	.126	.102	1	—	—	512961
12	300	96	TCG	.126	.102	30mm	2/7/42, 2/9/46 & 2/10/60	—	512961-30
14	350	100	TCG	.146	.118	5/8	—	Pistorious	514101-5/8HD
14	350	108	TCG	.126	.102	1	—	—	514108
14	350	108	TCG	.126	.102	30mm	2/7/42, 2/9/46 & 2/10/60	—	514108-30
15	375	100	TCG	.120	.098	1	—	Hitachi	515101 †
16	400	120	TCG	.150	.126	1	—	—	516121
18	450	120	TCG	.150	.126	1	—	—	518121
20	500	120	TCG	.174	.140	1	—	—	520121
20	500	120	TCG	.174	.156	30mm	2/7/42, 2/9/46 & 2/10/60	—	520121-30

† For Hitachi Miter box (Thin Kerf).

* Electro Blu™ Non-Stick Coating.

WARNING: Never attempt to cut ferrous metals (steel, iron, etc.) with the saw blades on this page.

* P.H. denotes pin-hole configuration, if applicable. Example: 2/10/60 = 2 @ 10mm dia. on 60mm circle.

Warning: Before use, read saw blade safety guidelines on pages 312-314.

INDUSTRIAL SAW BLADES

RADIAL ARM

-2° & 0° Hook • 4 ATB & 1 Raker or ATB

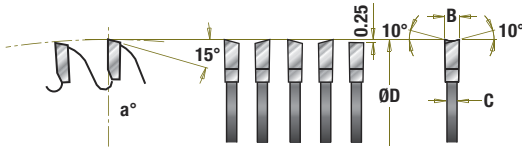

Designed especially for radial arm saws, sliding compound miter saws and others with the blade above the work-piece, these blades minimize the tendency to self-feed. They feature a low tooth count and an ATB plus raker grind (typically used on combination blades). Excellent choice for cutting hardwood and softwood. For plywood, use tool #610720, which has a high tooth count and an ATB grind.



Combination Rip/Crosscut



Cabinet Plywood Rip/Crosscut •

ØD		Teeth	Grind	a°	'B' Kerf Inch	'C' Plate Inch	Bore	Tool No.
Inch	mm							
10	250	24	ATB	-2°	.134	.095	5/8	RA1024
10	250	72	ATB	0°	.126	.095	5/8	610720 •
12	300	36	ATB	0°	.150	.110	1	RA1236
14	350	40	4&1	-2°	.165	.110	1	RA1440
14	350	42	ATB	0°	.165	.110	1	RA1442
16	400	40	4&1	-2°	.165	.118	1	RA1640
16	400	48	ATB	0°	.165	.118	1	RA1648

• For plywood use #610720.

HOLZ-HER® PANEL SAW

220mm

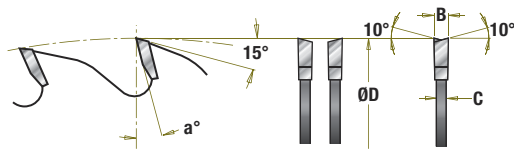

Designed specifically for the Holz-Her® 220mm panel saws. Blades are available for general purpose cutting, crosscutting and sawing laminates, melamine, acrylic and other plastics and solid surface materials. Blades with tips made of the high-performance DITEC™ carbide, an Amana Tool® exclusive, are also included in this line.

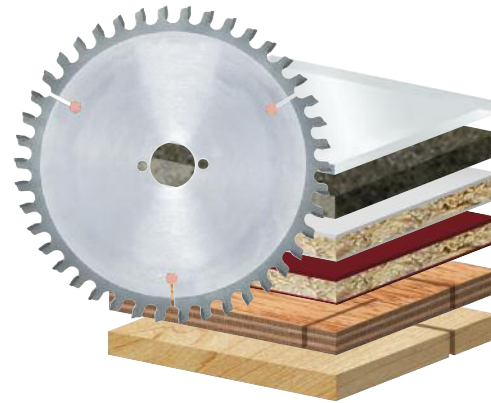

Soft/Hardwood Crosscut



Cabinet Plywood Rip/Crosscut



Plastic Laminate Single & Double Sided



Melamine Single & Double Sided



Solid Surface



Acrylic & Non-Melt Plastic

ØD mm	Teeth	Grind	a°	'B' Kerf Inch	'C' Plate Inch	Bore	*P.H.	Application	Tool No.
220	34	ATB	10°	.118	.079	30mm	2/7/42	General Purpose	220T340
220	64	ATB	10°	.118	.079	30mm	2/7/42	Crosscut Wood	220T640
220	64	TCG	10°	.118	.079	30mm	2/7/42	Laminate/MDF	220T641
220	64	TCG	-2°	.126	.079	30mm	2/7/42	Plastic Non-Melt	LB220T641
220	42	HG	-6°	.126	.087	30mm	2/7/42	Melamine	HG220T420
220	42	H-ATB	-6°	.110	.087	30mm	2/7/42	Melamine	MB220T420
220	64	H-ATB	0°	.126	.079	30mm	2/7/42	DITEC™ Melamine	DT220T640 †
220	64	TCG	10°	.126	.079	30mm	2/7/42	DITEC™ Laminate/MDF	DT220T641 †

† Denotes high-performance DITEC™ carbide.

* P.H. denotes pin-hole configuration, if applicable.

Example: 2/10/60 = 2 @ 10mm dia. on 60mm circle.

▲ Warning: Before use, read saw blade safety guidelines on pages 312-314.

DITEC™

EXTRA STRENGTH CARBIDE

- Exclusive carbide grade
- Long lasting
- Smooth cuts

Amana Tool®

Amana Tool

DITEC™ SAW BLADES

Exclusive DITEC™ Carbide Tips Provide At Least Twice The Output Of Conventional Grade Carbide

Unique, long-life saw blades made for cutting chipboard and plywood with/without coating. Teeth produced from special micro-grain quality, thus durable against wear while working with abrasive material. Intended for table saw and panel sizing machines. It's straightening maintained for a long period due to a unique method which does not harm the structure of the saw body steel. With the use of static balancing, increased stability is ensured to preserve the machine bearings.

DITEC™ MELAMINE

0° Hook • 'HIGH-ATB' GRIND

If you cut melamine on a regular basis, this is the blade you should use. It has the same features as our regular melamine blades – the MB series and MSB series (see page 282-283) – such as a thicker than standard plate, high tooth count, and the H-ATB grind, but this blade has long-lasting DITEC™ carbide tips.

- ✓ Exclusive DITEC™ Carbide Tips
- ✓ Higher Reliability & Lower Maintenance
- ✓ Low Noise Level
- ✓ Laser Cut Saw Bodies
- ✓ Excellent Cutting Quality

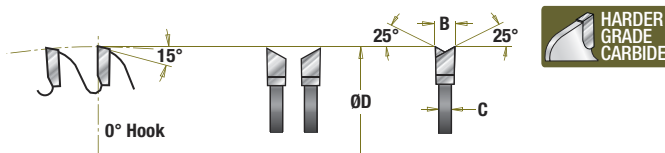

ØD		Teeth	Grind	'B' Kerf	'C' Plate	Bore	*P.H.	Tool No.
Inch	mm							
—	220	64	H-ATB	.126	.079	30mm	2/7/42	DT220T640 †
10	250	72	H-ATB	.126	.102	5/8	—	DT10720
10	250	72	H-ATB	.126	.102	30mm	2/7/42, 2/9/46 & 2/10/60	DT10720-30
12	300	84	H-ATB	.126	.102	1	—	DT12840
12	300	84	H-ATB	.126	.102	30mm	2/7/42, 2/9/46 & 2/10/60	DT12840-30

† For Holz-Her® 220mm panel saws.

* P.H. denotes pin-hole configuration, if applicable.
Example: 2/10/60 = 2 @ 10mm dia. on 60mm circle.

▲ **Warning:** Before use, read saw blade safety guidelines on pages 312-314.

DITEC™ SLIDING TABLE

10° Hook • ATB or TC Grind

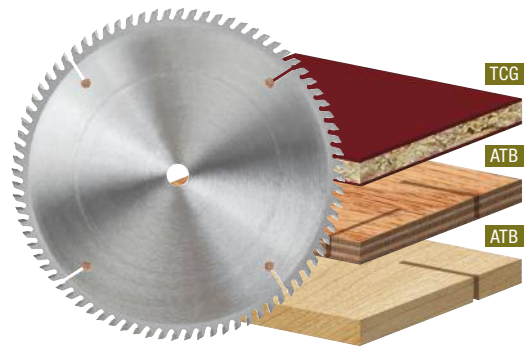
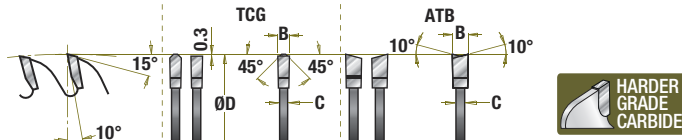

These high-performance crosscutting blades are designed primarily for use in sliding table saws, such as Striebig®, Altendorf®, SCMI® & Delta® models. They are also suitable for use in regular table saws. The blades incorporate an exceptional array of features: high tooth count, a choice of alternate top bevel or triple chip grind, expansion slots and turbulence-dampening copper plugs. The DITEC™ carbide tips add exceptional sharpness and long tool life to these features. Choose the ATB grind for solid wood or plywood, the TC grind for MDF, OSB, HDF, single or double-sided melamine and plastic laminated panels.

ØD		Teeth	Grind	'B' Kerf	'C' Plate	Bore	*P.H.	Tool No.
Inch	mm							
10	250	80	ATB	.126	.087	5/8	—	DT10800
12	300	72	ATB	.126	.087	1	—	DT12720
12	300	72	ATB	.126	.087	30mm	2/7/42, 2/9/46 & 2/10/60	DT12720-30 †
12	300	96	ATB	.126	.087	1	—	DT12960
12	300	96	ATB	.126	.087	30mm	2/7/42, 2/9/46 & 2/10/60	DT12960-30 †
14	350	84	ATB	.137	.098	1	—	DT14840
14	350	84	ATB	.137	.098	30mm	2/7/42, 2/9/46 & 2/10/60	DT14840-30
14	350	108	ATB	.137	.098	30mm	2/7/42, 2/9/46 & 2/10/60	DT14108-30
10	250	60	TCG	.126	.087	5/8	—	DT10601
10	250	80	TCG	.126	.087	5/8	—	DT10801
10	250	80	TCG	.126	.087	30mm	2/7/42, 2/9/46 & 2/10/60	DT10801-30
12	300	72	TCG	.126	.087	1	—	DT12721
12	300	72	TCG	.126	.087	30mm	2/7/42, 2/9/46 & 2/10/60	DT12721-30 †
12	300	96	TCG	.126	.087	1	—	DT12961
12	300	96	TCG	.126	.087	30mm	2/7/42, 2/9/46 & 2/10/60	DT12961-30 †
14	350	84	TCG	.137	.098	1	—	DT14841
14	350	84	TCG	.137	.098	30mm	2/7/42, 2/9/46 & 2/10/60	DT14841-30
14	350	108	TCG	.137	.098	1	—	DT14109
14	350	108	TCG	.137	.098	30mm	2/7/42, 2/9/46 & 2/10/60	DT14109-30

† Fits Striebig® vertical panel saw.

DITEC™ SOLID SURFACE

0° Hook • Special TC-22 Modified Grind

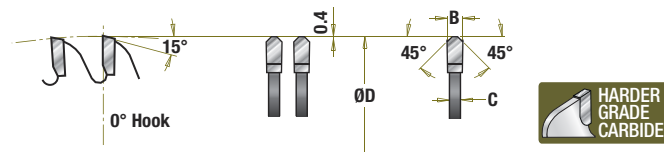

These blades are designed for cutting plastic laminate, Plexiglas® and solid surface materials such as Dupont Corian®, Wilsonart®, Gibraltar® and Fountainhead®. The DITEC™ carbide tips are ground in a triple chip geometry unique to this blade and leave a swirl-free cut in solid surface materials.

The thick, stable plate reduces vibration that degrades the cut and shortens tool life. The blade is suitable for a variety of saw configurations. Its 0° hook angle virtually eliminates self-feeding when used with a radial arm saw, miter saw and table saw.

ØD		Teeth	Grind	'B' Kerf	'C' Plate	Bore	*P.H.	Tool No.
Inch	mm							
10	250	72	S-TCG	.126	.102	5/8	—	DT10721
12	300	84	S-TCG	.126	.102	1	—	DT12841
12	300	84	S-TCG	.126	.102	30mm	2/7/42, 2/9/46 & 2/10/60	DT12841-30

* P.H. denotes pin-hole configuration, if applicable.

Example: 2/10/60 = 2 @ 10mm dia. on 60mm circle.

▲ **Warning:** Before use, read saw blade safety guidelines on pages 312-314.

DITEC™ ADJUSTABLE TYPE SCORING SETS

12° Hook • Alternate Top Bevel (ATB) Grind

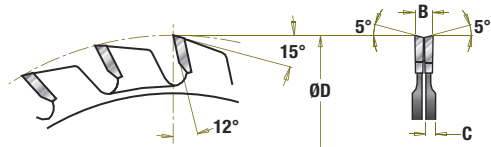

Scoring Particleboard & Double Sided Laminate

Used on panel saws or sliding table saws with separate scoring units for chip-free cuts on both sides of the material. Adjustable scoring sets consist of two 12-tooth saw blades with shims to adjust the kerf width (2.8mm to 3.6mm). Used in combination with our industrial saw blades with standard kerf (example #612721, #DT12721, etc.).

ØD	Teeth	Grind	'B' Kerf	'C' Plate	Bore	Machine Application	Tool No.
120mm	12 x 2	ATB	2.8mm to 3.6mm	2mm(x2)	20mm	Altendorf®, Martin, Mrozek	DT120T14-20
120mm	12 x 2	ATB	2.8mm to 3.6mm	2mm(x2)	22mm	Altendorf®, Martin, Mrozek	DT120T14

Note: Adjustable scoring sets with 22mm bore can be converted to either 3/4" bore by ordering two each #BU-130 bushings, or to 20mm bore by ordering two each #BU-140 bushings.

Replacement 5-piece shim set (0.6mm, .10mm, .20mm (2) and 2.8mm) order No. 'Shim Set'. Will fit 20mm or 22mm scoring sets.

DITEC™ CONICAL TYPE SCORING SETS

8° Hook • Conical Alternate Top Bevel (ATB) Grind

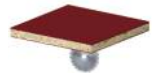
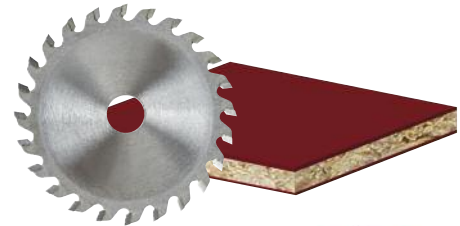
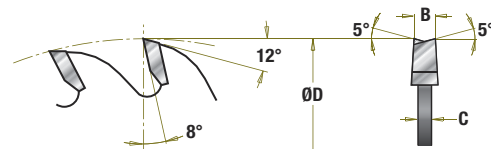

Scoring Particleboard & Double Sided Laminate

Used on panel saws with separate scoring units for chip-free cuts on both sides of the material. With conical type scoring blades, the kerf width changes with depth of penetration. Used in combination with our industrial saw blades '7' series only (#714721, etc.). Also used in combination with the DITEC™ series panel saw main blades. Kerf range should match the main blade.

ØD	Teeth	Grind	'B' Kerf	'C' Plate	Bore	Machine Application	Tool No.
120mm	24	Conical	3.2mm to 4.2mm	2.2mm	20mm	Altendorf®	DT120T20
120mm	24	Conical	4.4mm to 5.4mm	2.8mm	20mm	Altendorf®, Martin, SCMI®	DT120T24

EDGEBANDER TRIM SAW

10° Hook • Alternate Top Bevel (ATB) Grind

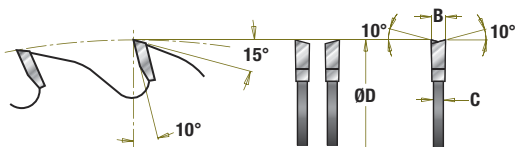

Soft/Hardwood Crosscut

Replacement trim saw blades for edgEBANDER machines feature alternate top bevel grind on the teeth, 10° hook angle, and standard thickness plates. Most machines require two blades.

ØD mm	Teeth	Grind	'B' Kerf Inch	'C' Plate Inch	Bore	Tool No.
150mm	30	ATB	.126	.087	30mm	663000
180mm	58	ATB	.126	.087	20mm	663010

#663000 is for IDM-137 and Ocmac Chica 290 edgEBANDERs, and others. 663010 is for Olimpic Nova-2 edgEBANDERs, and others.

* P.H. denotes pin-hole configuration, if applicable.

Example: 2/10/60 = 2 @ 10mm dia. on 60mm circle.

Warning: Before use, read saw blade safety guidelines on pages 312-314.

EZ-Dial™

Shim-Free

- Adjustable in increments of 0.1mm
- Fits most machines



EZ DIAL™ SCORING SET

Adjustments can easily be made while the scoring set is mounted on the machine! Adjusting the scoring set is quick and easy, simply turn the dial to adjust the width of the score. Eliminates the need for shims, endless measuring, reassembling, testing and adjusting to obtain the required width.

- Fully adjustable in increments of 0.1mm.
- Kerf adjusts from 2.8mm to 3.6mm.
- Available in 100mm and 120mm diameters with 15mm, 20mm, 22mm and 3/4" bores.
- Replacement blades available.
- Fits most machines including Altendorf® and SCM.

ØD	Kerf mm	Teeth	Bore	Repl. Dial Screw	Repl. Dial Key	Tool No.
100mm	2.8 to 3.6	12x2	22mm & 3/4"	67020	5011	EZ100-24-22*
120mm	2.8 to 3.6	12x2	20mm	67020	5011	EZ120-24-20
120mm	2.8 to 3.6	12x2	15mm, 22mm & 3/4"	67021	5011	EZ120-24-22**+

* Includes bushing part #BEZ-01 from 22mm to 3/4"

** Fits additional machines: Casolin Astra Top, Casadei Shark & Lazzari.

+ Chamfered dial for SCM machine. #BEZ-015 from 22mm to 15mm.

Replacement Parts:

Saw Blades

100mm	12x2	REZ100
120mm	12x2	REZ120
125mm	12x2	REZ125

Re-Sharpener Adapter

For 100mm	EZA-08
For 120mm and 125mm	EZA-10

Spring

For 100mm	EZA-12
For 120mm and 125mm	EZA-14

Replacement screws for blade hub #67022.

Replacement key for blade hub #5007.

Replacement pins #SSP-005.



Re-Sharpener Adapter
#EZA-08 for 100mm



Re-Sharpener Adapter
#EZA-10 for 120mm and 125mm



Panel Sizing/Scoring



Scoring Particleboard &
Double Sided Laminate



* P.H. denotes pin-hole configuration, if applicable.

Example: 2/10/60 = 2 @ 10mm dia. on 60mm circle.

▲ **Warning:** Before use, read saw blade safety guidelines on pages 312-314.

CONICAL TYPE SCORING

8° Hook • Conical ATB Grind

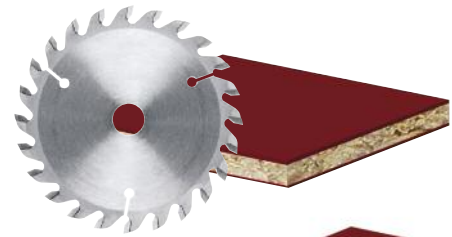
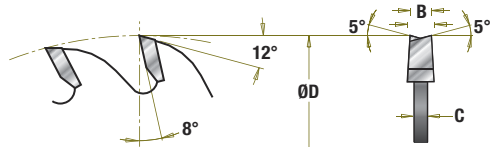

Scoring Particleboard & Double Sided Laminate

This conical-type scoring blade is similar to the DITEC™ scoring blade, but features our standard carbide tips. Match the kerf width of your main blade by adjusting the scoring blade's cutting depth. Range typically is 1mm (for example, from 4.4mm to 5.4mm). Select a scoring blade with a range matching your main blade's kerf width. Use in combination only with our '7' series industrial saw blades (#714721, #716961, etc.). Use also in combination with the new DITEC™ panel saw blades.

ØD mm	Teeth	Grind	'B' Kerf Range		'C' Plate		Bore mm	Machine Application	Tool No.
			mm	Inches	mm	Inches			
100	20	ATB	3.2 to 4.2	.125 to .165	2.2	.086	20	Various	SS100T20
120	24	ATB	3.2 to 4.2	.125 to .165	2.2	.086	20	Various	SS120T20
150	24	ATB	4.0 to 5.0	.157 to .196	2.8	.110	20	Various	SS150T24
200	36	ATB	4.4 to 5.4	.173 to .212	2.8	.110	20	Shelling, Holzma	SS200T36

Note: Due to many different scoring machine sizes (particularly arbor sizes), it is advisable to measure both the scoring and main blades that are presently on your machine (diameter, bore, kerf, etc.).

Note: Standard bore is 20mm. Other kerf sizes available, please inquire.

ADJUSTABLE TYPE SCORING SETS

12° Hook • ATB Grind

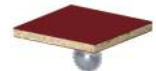
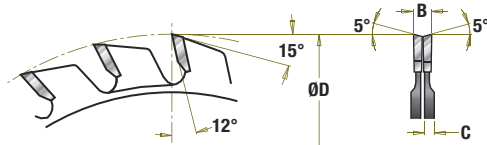

Scoring Particleboard & Double Sided Laminate

Used on panel saws and sliding table saws with separate scoring units for chip-free cuts on both sides of the material. Adjustable scoring sets consist of two 12-tooth saw blades with shims to adjust the kerf width (2.8mm to 3.6mm). Used in combination with our industrial saw blades '6' series only. (Example: #614721, #616961, etc.).

ØD mm	Teeth	Grind	'B' Kerf Range		'C' Plate		Bore mm	Machine Application	Tool No.
			mm	Inches	mm	Inches			
100	12x2	ATB	2.8 to 3.6	.110 to .142	2(x2)	.078(x2)	20	Shelling	SS100T12
100	12x2	ATB	2.8 to 3.6	.110 to .142	2(x2)	.078(x2)	*22	Altendorf,® Delta,® Martin, Mrozek, Panhans	SS100T14
120	12x2	ATB	2.8 to 3.6	.110 to .142	2(x2)	.078(x2)	20	SCMI®	SS120T12
120	12x2	ATB	2.8 to 3.6	.110 to .142	2(x2)	.078(x2)	*22	Altendorf,® Martin, Mrozek	SS120T14
125	12x2	ATB	2.8 to 3.6	.110 to .142	2(x2)	.078(x2)	20	Griggio	SS125T14

Note: Due to many different scoring machine sizes (particularly arbor sizes), it is advisable to measure both the scoring and main blades that are presently on your machine (diameter, bore, kerf, etc.).

* Adjustable scoring sets with 22mm bore can be converted to either 3/4" bore by ordering two each #BU-130 bushings, or to 20mm bore by ordering two each #BU-140 bushings.

8-piece shim set #SHIM-SET (3pcs 0.5mm, 2pcs 0.15mm and 3pcs 0.20mm). Will fit 20mm or 22mm scoring sets.

* P.H. denotes pin-hole configuration, if applicable.

Example: 2/10/60 = 2 @ 10mm dia. on 60mm circle.

Warning: Before use, read saw blade safety guidelines on pages 312-314.

DYNAMICALLY BALANCED SAW BLADES

Unique, long-life saw blades made for cutting chipboard and plywood with/without coating. Teeth are produced from special micro-grain quality, thus durable against wear while working with abrasive material. Intended for table saw and panel sizing machines. It's straightening maintained for a long period due to unique method which does not harm the structure of the saw body steel. With the use of static balancing, increased stability is ensured to preserve the machine bearings.

DITEC™ DYNAMIC PANEL SAWING

TCG (Triple Chip Grind) • Extended Life

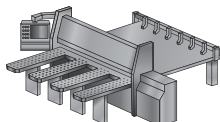

Manufacturing Technology:



Balanced
G 6.3



Dynamic
Straightness



Pressure

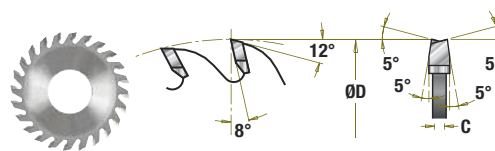
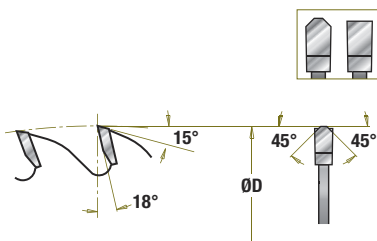

Main Saw for Panel Sizing Laminated Boards

Machine Style	ØD mm	Teeth Count	Kerf/Plate mm	Bore mm	*P.H.	Tool No.
Anthon LNA	400	72	4.4/3.2	60	2/11/85	DT400T721-60
Gabbiani	355	72	4.4/3.0	80	4/9/100, 2/7/110	DT355T721-80
	380	60	4.4/3.2	60	4/9/100	DT380T601-60
	400	60	4.4/3.2	80	4/9/100, 2/7/110	DT400T601-80
	400	72	4.4/3.2	80	—	DT400T721-80
	500	72	4.8/3.5	80	2/8/110 & 2/10/130	DT500T721-80A
Giben	450	72	4.4/3.2	75	—	DT450T721-75
Giben	500	72	5.0/3.5	75	—	DT500T721-75B
Giben	550	72	5.0/3.5	100	—	DT550T721-100B
Giben Junior	305	60	4.4/3.2	75	—	DT305T601-75
Giben Trend	355	72	4.4/3.2	75	—	DT355T721-75
Giben Trend	400	60	4.4/3.2	75	4/15/105	DT400T601-75
Holz-Her®	220	64	3.0/2.2	30	2/7/42	DT220T641
Holzma	355	72	4.4/3.2	60	2/14/100	DT355T721-60
	380	60	4.4/3.2	60	4/9/100, 2/14/100	DT380T601-60
	420	72	4.8/3.5	60	—	DT420T721-60A
	450	72	4.4/3.2	60	2/14/125, 2/10/80	DT450T721-60
	500	60	4.8/3.5	60	—	DT500T601-60A
	500	72	4.8/3.5	60	2/11/115	DT500T721-60A
	500	72	5.0/3.5	60	—	DT500T721-60B
	540	72	4.8/3.5	60	2/11/115, 2/19/120	DT540T721-60
	600	72	5.8/4.0	60	2/19/120, 2/11/115	DT600T721-60
Mayer	355	54	4.4/3.0	30	2/7/42, 2/10/60	DT355T541-30
	355	72	4.4/3.0	30	2/7/42, 2/10/60	DT355T721-30
	400	72	4.4/3.2	30	2/7/42, 2/10/60	DT400T721-30
New Sigma 115	400	72	4.4/3.2	80	—	DT400T721-80
New Sigma 90	355	54	4.4/3.2	30	2/7/42, 2/10/60	DT355T541-30
Panhans	305	48	4.4/3.2	30	—	DT305T481-30
	355	54	4.4/3.2	30	2/7/42, 2/10/60	DT355T541-30
	355	72	4.4/3.0	30	2/7/42, 2/10/60	DT355T721-30

Scorer for Panel Sizing

ØD mm	Teeth Count	Fits Main Saw Kerf	Bore mm	*P.H.	Tool No.
180	30	4.4/5.4	20	—	DT180T30-20
200	36	4.4/5.4	65	4/9/110	DT200T36-65
160	36	4.4/5.4	55	3/7/66	DT160T36-55
200	36	4.8/5.8	65	2/9/100	DT200T36-65A
200	36	4.8/5.8	65	2/9/100	DT200T36-65A
160	36	4.4/5.4	55	3/7/66	DT160T36-55
125	24	4.4/5.4	45	—	DT125T24-45
125	24	4.4/5.4	45	—	DT125T24-45
125	24	4.4/5.4	45	—	DT125T24-45
180	30	4.4/5.4	45	—	DT180T30-45
200	36	4.4/5.4	65	4/9/110	DT200T36-65
200	36	4.8/5.8	45	—	DT200T36-45A
200	36	4.4/5.4	45	—	DT200T36-45
200	36	4.8/5.8	45	—	DT200T36-45A
200	36	4.8/5.8	45	—	DT200T36-45A
200	36	4.8/5.8	45	—	DT200T36-45A
200	36	4.4/5.4	45	—	DT200T36-45
200	36	5.8/6.8	45	—	DT200T36-45B
160	36	4.4/5.4	55	3/7/66	DT160T36-55
180	30	4.4/5.4	30	—	DT180T30-30
180	30	4.4/5.4	30	—	DT180T30-30
180	30	4.4/5.4	30	—	DT180T30-30

* P.H. denotes pin-hole configuration, if applicable.

Example: 2/10/60 = 2 @ 10mm dia. on 60mm circle.

▲ **Warning:** Before use, read saw blade safety guidelines on pages 312-314.

DITEC™ DYNAMIC PANEL SAWING

TCG (Triple Chip Grind) • Extended Life

Dynamically balanced saw blades ensures saw blade stability for a clean cut.

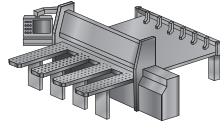

Manufacturing Technology:



Balanced
G 6.3



Dynamic
Straightness



Pressure

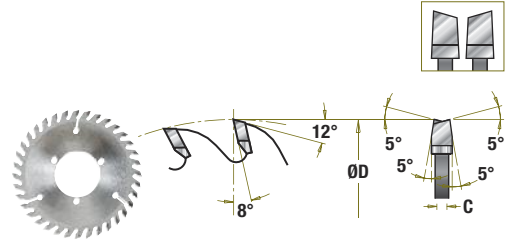
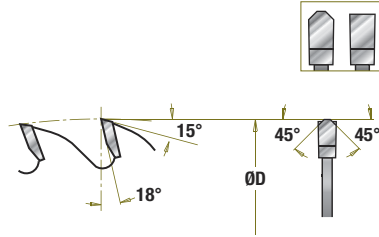

Main Saw for Panel Sizing Laminated Boards

Machine Style	ØD mm	Teeth Count	Kerf/Plate mm	Bore mm	*P.H.	Tool No.
Prismatic No.1	400	72	4.4/3.2	75	4/15/105	DT400T721-75
Prismatic No.2	430	96	4.4/3.2	75	4/15/105	DT430T961-75
Prismatic No.2	430	96	4.4/3.2	50	3/15/80	DT430T961-50
Prismatic No.3	470	96	4.4/3.2	75	4/15/105	DT470T961-75
Prismatic No.3	500	72	4.4/3.2	75	—	DT500T721-75
Prismatic No.3	500	72	4.8/3.5	75	—	DT500T721-75A
Prismatic No.3	550	72	5.0/3.5	100	—	DT550T721-100B
Schelling	350	72	4.4/3.2	30	2/7/42, 2/10/60	DT350T721-30
	355	72	4.4/3.2	30	2/7/42, 2/10/60	DT355T721-30
	370	72	4.4/3.2	30	2/10/60	DT370T721-30
	400	72	4.4/3.2	30	2/7/42, 2/10/60	DT400T721-30
	450	72	4.4/3.2	30	2/12/94	DT450T721-30
	550	72	5.0/3.5	40	—	DT550T721-40
Selco	355	72	4.4/3.2	80	4/9/100	DT355T721-80
					2/14/110, 2/7/110	
	400	72	4.4/3.2	80	—	DT400T721-80
	400	72	4.4/3.2	80	2/9/130	DT400T721-2PH
	430	72	4.4/3.2	80	4/19/120, 2/9/130	DT430T721-80
	450	72	4.4/3.2	80	4/19/120, 2/9/130	DT450T721-80
	450	72	4.8/3.5	80	4/19/120, 2/9/130	DT450T721-80A
Sigma65K	305	72	4.4/3.2	80	4/9/100	DT305T721-80
					2/14/110, 2/7/110	
Sigma65K	380	72	4.4/3.5	80	4/9/120, 2/9/130	DT380T721-80
Sigma90	355	72	4.4/3.0	30	2/7/42, 2/10/60	DT355T721-30
Various	305	60	4.4/3.2	30	—	DT305T601-30
Various	380	72	4.4/3.2	75	—	DT380T721-75
Various	380	72	4.8/3.5	60	—	DT380T721-60A
Various	450	72	4.8/3.5	80	—	DT450T721-80A
Various	480	72	4.8/3.5	80	4/19/120	DT480T721-80A
Various	550	72	5.0/3.5	40	—	DT550T721-40

Scorer for Panel Sizing

ØD mm	Teeth Count	Fits Main Saw Kerf mm	Bore mm	*P.H.	Tool No.
160	36	4.4/5.4	45	3/15/70	DT160T36-45
215	42	4.4/5.4	50	3/15/80	DT215T42-50
215	42	4.4/5.4	50	3/15/80	DT215T42-50
125	24	4.4/5.4	45	—	DT125T24-45
125	24	4.8/5.8	45	—	DT125T24-45A
180	30	5.0/6.0	55	—	DT180T30-55
200	36	4.4/5.4	20	—	DT200T36-20
200	36	4.4/5.4	20	—	DT200T36-20
200	36	4.4/5.4	20	—	DT200T36-20
200	36	4.4/5.4	20	—	DT200T36-20
200	36	5.0/6.0	20	—	DT200T36-20A
200	36	4.4/5.4	65	4/9/110	DT200T36-65
200	36	4.4/5.4	65	4/9/110	DT200T36-65
200	36	4.4/5.4	65	4/9/110	DT200T36-65
200	36	4.4/5.4	65	4/9/110	DT200T36-65
200	36	4.8/5.8	65	4/9/110	DT200T36-65A
160	36	4.4/5.4	55	3/7/66	DT160T36-55
160	36	4.4/5.4	55	3/7/66	DT160T36-55
160	36	4.4/5.4	55	3/7/66	DT160T36-55

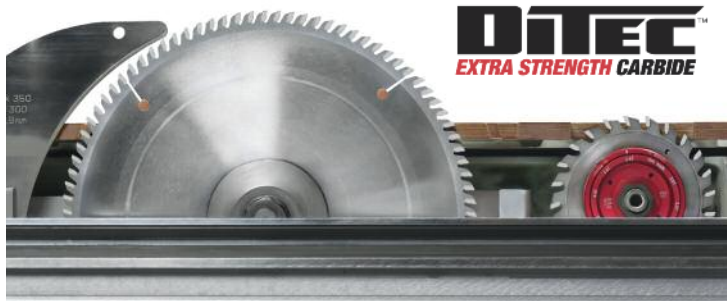

* P.H. denotes pin-hole configuration, if applicable.

Example: 2/10/60 = 2 @ 10mm dia. on 60mm circle.

Warning: Before use, read saw blade safety guidelines on pages 312-314.

DITEC™ DYNAMIC PANEL SAWING

ATB (Alternate Top Bevel) • Extended Life

Dynamically balanced saw blades ensures saw blade stability for a clean cut.

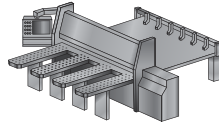

Manufacturing Technology:



Balanced
G 6.3



Dynamic
Straightness



Pressure

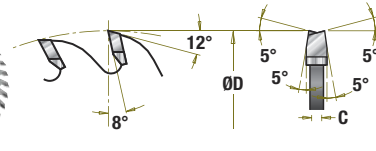
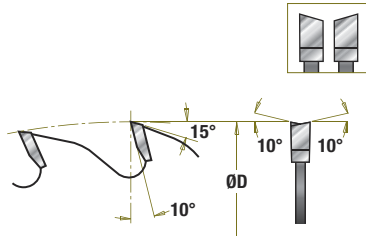

Main Saw for Panel Sizing Laminated Boards

Machine Style	ØD mm	Teeth Count	Kerf/Plate mm	Bore mm	*P.H.	Tool No.
Gabbiani	355	72	4.4/3.0	80	4/9/100 & 2/7/110	DT355T720-80
	400	72	4.4/3.2	80	4/9/100 2/7/110 & 2/14/110	DT400T720-80
Giben	355	72	4.4/3.0	75	—	DT355T720-75
	400	60	4.4/3.2	75	—	DT400T600-75
	400	72	4.4/3.2	75	4/15/115	DT400T720-75
Giben Trend	355	54	4.4/3.0	75	—	DT355T540-75
Panhans	305	60	4.4/3.0	30	2/7/42, 2/10/60	DT305T600-30
	450	72	4.4/3.2	30	2/7/42, 2/10/60	DT450T720-30
Schelling	400	60	4.4/3.2	30	2/10/60	DT400T600-30
Various	430	72	4.4/3.2	30	—	DT430T720-30

Scorer for Panel Sizing

ØD mm	Teeth Count	Fits Main Saw Kerf mm	Bore mm	*P.H.	Tool No.
160	36	4.4/5.4	55	3/7/66	DT160T36-55
160	36	4.4/5.4	55	3/7/66	DT160T36-55
125	24	4.4/5.4	45	—	DT125T24-45
125	24	4.4/5.4	45	—	DT125T24-45
125	24	4.4/5.4	45	—	DT125T24-45
200	36	4.4/5.4	20	—	DT200T36-20

* P.H. denotes pin-hole configuration, if applicable.

Example: 2/10/60 = 2 @ 10mm dia. on 60mm circle.

Warning: Before use, read saw blade safety guidelines on pages 312-314.

DITEC™ DYNAMIC CONICAL TYPE SCORING SAW

8° Hook Conical ATB Grind

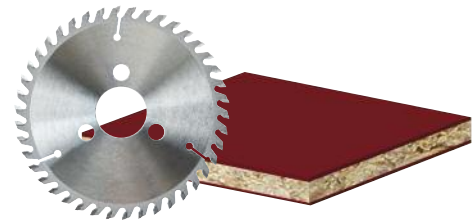
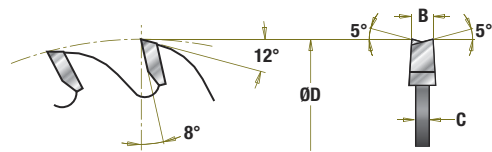

Dynamically balanced saw blades ensure saw blade stability for a clean cut. Used on panel saws with separate scoring units for chip-free cuts on both sides of the material. With conical type scoring blades, the kerf width changes with depth of penetration. Used in combination with our industrial saw blades '7' series only (#714721, etc.). Also used in combination with the new DITEC™ series panel saw main blades on pages 292 & 293. Kerf range should match the main blade.

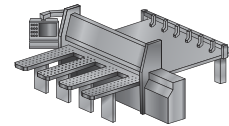

Machine Style	ØD mm	Teeth Count	'B' Kerf mm	'C' Plate mm	Bore	*P.H.	Tool No.
Giben	125	24	4.4 to 5.4	3.2	45mm	—	DT125T24-45
	125	24	4.8 to 5.8	3.2	45mm	—	DT125T24-45A
	180	30	5.2 to 6.2	3.5	55mm	—	DT180T30-55
	300	48	4.4 to 5.4	3.2	50mm	3/15/80	DT300T48-50
Giben Prismatic	160	36	4.4 to 5.4	3.2	45mm	3/15/70	DT160T36-45
	215	42	4.4 to 5.4	3.2	50mm	3/15/80	DT215T42-50
Holzma	175	28	4.4 to 5.4	3.2	45mm	—	DT175T28-45
	175	28	4.8 to 5.8	3.2	45mm	—	DT175T28-45A
	180	30	4.4 to 5.4	3.2	45mm	—	DT180T30-45
	200	36	4.4 to 5.4	3.2	45mm	—	DT200T36-45
	200	36	4.8 to 5.8	3.5	45mm	—	DT200T36-45A
Martin	125	24	4.4 to 5.4	3.2	22mm	—	DT125T24-22
Mayer	150	24	4.4 to 5.4	3.2	30mm	—	DT150T24-30
Panhans	180	30	4.4 to 5.4	3.2	30mm	—	DT180T30-30
Schelling	180	30	4.4 to 5.4	3.2	20mm	—	DT180T30-20
	200	36	4.4 to 5.4	3.2	20mm	—	DT200T36-20
	200	36	5.0 to 6.0	3.5	20mm	—	DT200T36-20A
	300	48	4.4 to 5.4	3.2	30mm	—	DT300T48-30
SCMI®	150	24	4.4 to 5.4	3.2	1-1/4"	—	DT150T24-32
Selco	200	36	4.4 to 5.4	3.5	65mm	2/8/110 & 2/10/110	DT200T36-65
Various	150	36	4.4 to 5.4	2.8	20mm	—	DT150T36
	160	36	4.4 to 5.4	3.5	55mm	—	DT160T36-55
	180	30	4.8 to 5.8	3.5	45mm	—	DT180T30-45A
	200	36	5.8 to 6.6	3.5	45mm	—	DT200T36-45B
	200	36	4.8 to 5.8	3.5	65mm	—	DT200T36-65A

Note: Please specify if your application requires 22mm, 30mm, 45mm bore, etc. Due to many different scoring machine sizes (particularly arbor sizes), it is advisable to measure both the scoring and main blades that are presently on your machine (diameter, bore, kerf, etc.).

BUSHINGS & STABILIZERS available, see page 303.

RE-BORING Services, see page 303.

* P.H. denotes pin-hole configuration, if applicable.

Example: 2/10/60 = 2 @ 10mm dia. on 60mm circle.

Warning: Before use, read saw blade safety guidelines on pages 312-314.

INDUSTRIAL

Super Fine

Chip-Free Dado Cuts



Veneered Plywood (Along & Across the Grain) Hardwood Melamine & Laminate



ELECTROBLU™
ECO-Friendly Non-Stick Coating
658060C

PRESTIGE™ SUPER FINE DADO SETS

With Six 4-Wing Chippers 1/4" to 29/32" • High ATB Grind

Our Prestige™ Dado Set cuts perfectly smooth edges, flat-bottom cuts and grooves both along and across the grain that are free of splinters or rough edges. This dado set is part of the renowned Prestige™ line of superior performance blades.

Features the latest in cutting tool technology including massive tool-steel plates and precision ground carbide teeth. The 8" diameter, 24-tooth outside plates are hollow ground for proper clearance and feature high ATB grind geometry with every sixth tooth flat ground for efficient chip removal. Each tooth body also features anti-kickback design to help prevent overfeeding.

Set accommodates today's undersized plywoods.

Packed In A Handy Black Molded Carrying Case.

Each of the six interior chippers features four teeth and the standard width capacity is 1/4" through 29/32". Adjustments can be easily made in 1/32" increments and even finer adjustments, as small as .002", can be made by using the supplied shim set. A 46-tooth dado set (see page 297) is also available for use with plywood and melamine.

A stacking dado set is an ideal tool for cutting dadoes, grooves and tenons for strong mortise-and-tenon joinery.

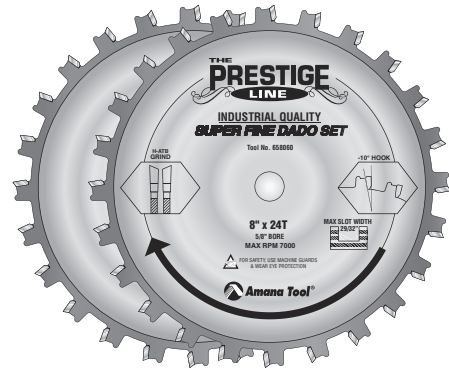

2 Outside 8" x 24T Blades

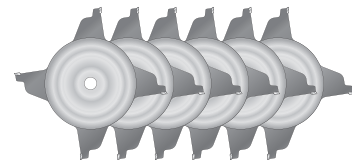

6 Carbide Tipped Four-Wing Chippers

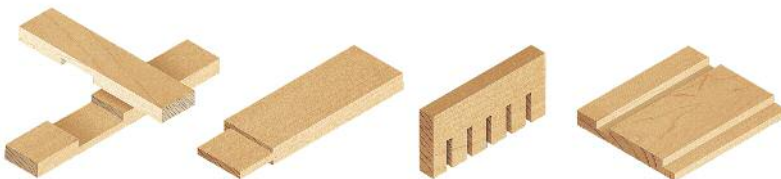

Half Lap Tenons Dentil Groove & Rabbets

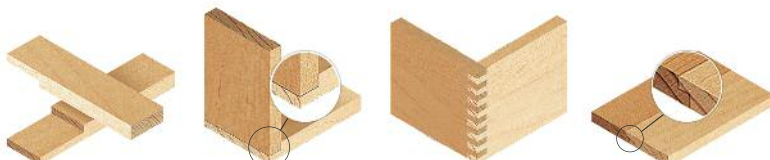

Corner Lap End Lap Box Joints Ship Lap

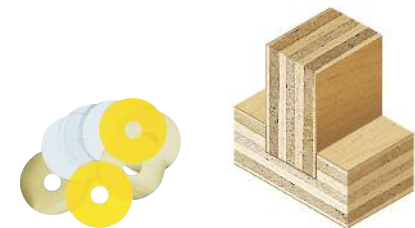

Set Includes Shim Set for Fine Adjustments

Set Accommodates Undersized Plywood

ØD	Hook Angle	†Teeth	Chippers	Grind	Kerf Range	Bore	Tool No.
8	-10°	24	1/8(x4), 3/32(x1), 1/16(x1)	H-ATB	1/4 to 29/32	5/8	658060
8	-10°	24	1/8(x4), 3/32(x1), 1/16(x1)	H-ATB	1/4 to 29/32	5/8	658060C *
8	-10°	24	1/8(x4), 3/32(x1), 1/16(x1)	H-ATB	1/4 to 29/32	30mm	658060-30 ‡
8	-10°	24	1/8(x4), 3/32(x1), 1/16(x1)	H-ATB	1/4 to 29/32	1	658060-1

† Teeth refers to the number of teeth for each outside saw blade.

* Electro Blu™ Non-Stick Coating.

Note: Always use the outside blades. Never attempt to use the chippers without the outside blades.

‡ No Pin-holes

* P.H. denotes pin-hole configuration, if applicable.

Example: 2/10/60 = 2 @ 10mm dia. on 60mm circle.

▲ Warning: Before use, read saw blade safety guidelines on pages 312-314.

DADO SETS

With Five 2-Wing Chippers 1/4" to 13/16" Groove ATB and FT Grind

Dadoes (cross-grain cuts) and grooves (cuts with the grain) are cut efficiently on the table saw with a dado stack set. Unlike a "wobbler," a stack set produces a flat-bottom cut with chip-free edges. Amana Tool® makes dado stack sets for every machine and every type of woodworking material. The standard width capacity ranges from 1/4" to 13/16". Additional chippers may be purchased separately to expand the capacity beyond 13/16". The standard set, regardless of diameter or tooth count, consists of two outside saw blades and four inside chippers. The outside blades feature hollow-ground plates for proper clearance, and alternate top bevel (ATB) grind with every sixth tooth flat ground (FT). See charts below for additional components.

For plywood and melamine, the sets with 46-tooth outside blades are recommended.

Rated excellent by:



Melamine
Single & Double Sided



Cabinet Plywood
Rip/Crosscut



Soft/Hardwood
Crosscut

46 Teeth
Only

18, 24 &
36 Teeth

ØD	Hook Angle	*Teeth	Chippers	Grind	Kerf Range	Bore	Plastic Molded Case	Tool No.
6	+15°	18	1/8(x4), 1/16(x1)	ATB/FT	1/4 to 13/16	5/8	Yes	656030
8	-5°	24	1/8(x4), 1/16(x1)	ATB/FT	1/4 to 13/16	5/8	Yes	658030
8	-5°	24	1/8(x4), 1/16(x1)	ATB/FT	1/4 to 13/16	30mm	Yes	658030-30 ‡
8	-5°	24	1/8(x4), 1/16(x1)	ATB/FT	1/4 to 13/16	1	Yes	658030-1
8	+15°	24	1/8(x4), 1/16(x1)	ATB/FT	1/4 to 13/16	5/8	Yes	658030-AK ▼
8	-5°	46	1/8(x4), 1/16(x1)	ATB/FT	1/4 to 13/16	5/8	Yes	658040 †
8	-5°	46	1/8(x4), 1/16(x1)	ATB/FT	1/4 to 13/16	30mm	Yes	658040-30 ‡†
8	-5°	46	1/8(x4), 1/16(x1)	ATB/FT	1/4 to 13/16	1	Yes	658040-1 †
10	+15°	24	1/8(x4), 1/16(x1)	ATB/FT	1/4 to 13/16	5/8	No	651030
10	+15°	24	1/8(x4), 1/16(x1)	ATB/FT	1/4 to 13/16	1	No	651030-1
12	+15°	24	1/8(x4), 1/16(x1)	ATB/FT	1/4 to 13/16	1	No	651230

† 8" x 46T set for super smooth cuts in cabinet grade plywoods and melamine.

▼ 'Anti-Kickback' design.

* Teeth refers to the number of teeth for each outside saw blade.

‡ No Pin-holes

Dado Combinations

Max. Width of Groove	Number of Chippers required	
	1/16	1/8
13/16	1	4
1-1/16	1	6
1-9/16	1	10
2-1/16	1	14
3-1/16	1	22
4-1/16	1	30



Handheld reusable plastic molded case and shim set included in all 6" & 8" diameter dado sets

* P.H. denotes pin-hole configuration, if applicable.

Example: 2/10/60 = 2 @ 10mm dia. on 60mm circle.

▲ **Warning:** Before use, read saw blade safety guidelines on pages 312-314.

DADO SHIM SETS

The perfect accessory for any dado set. Each set includes 14 color-coded plastic shims in various thicknesses for precise adjustment of your dado set. Especially useful when cutting plywood and other materials that are slightly under or oversized.



14 Piece Shim Set
DSS-100 Shown

Bore	Tool No.
5/8	DSS-100
1	DSS-101
30mm	DSS-102
1-1/4	DSS-103
5/8	DSS-106 *

* #DSS-106 includes 10 shims.

Each set includes the following:

Quantity Shims	Thickness		Color	ØD
	Inch	mm		
5	0.002	0.05mm	Gold	60mm
1	0.005	0.15mm	Violet/Orange	60mm
4	0.010	0.25mm	Clear	60mm
4	0.020	0.50mm	White	60mm

DSS-106 includes the following:

Quantity Shims	Thickness		Color	ØD
	Inch	mm		
2	0.002	0.05mm	Silver	60mm
1	0.005	0.15mm	Violet	60mm
1	0.010	0.25mm	Clear	60mm
6	0.020	0.50mm	White	60mm

INDIVIDUAL DADO SET COMPONENTS: DADO CHIPPERS

Flat Top (FT) Grind • Two Teeth Per Chipper

Amana Tool® has a full range of replacement parts for our dado sets, including chippers and outside blades. This allows you to replace damaged cutters and to expand the range of a standard set. These parts are manufactured to the same exacting standards as the full sets.

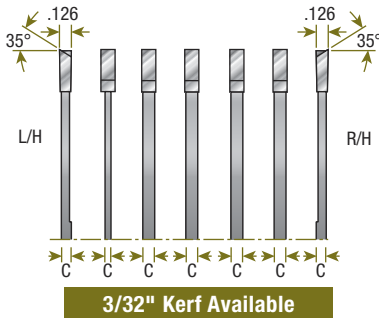

Order Number Chipper Thickness:

ØD	Bore	'C' 1/16	'C' 1/8	'C' 3/32
6	5/8	651660	651860	—
8	5/8	651680	651880	651280
8	5/8	▼ 651680-AK	▼ 651880-AK	—
8	1	651680-1	651880-1	—
10	5/8	651610	651810	—
10	1	651610-1	651810-1	—
12	1	651612	651812	—

▼ 8" 'Anti-Kickback' chippers.

DADO OUTSIDE BLADES

ATB Grind



ØD	Bore	Teeth	Kerf	Order No.	Order No.
				L/H	R/H
6	5/8	18	.126	656010	656010-R
8	5/8	24	.126	658010	658010-R
8	5/8	24	.126	▼ 658010-AK	▼ 658010-AK-R
8	1	24	.126	658010-1	658010-1-R
8	5/8	46	.126	658020	658020-R
8	1	46	.126	658020-1	658020-1-R
10	5/8	24	.126	651010	651010-R
10	1	24	.126	651010-1	651010-1-R
12	1	24	.126	651210	651210-R

▼ 8" 'Anti-kickback' outside blades.

Note: Specify left or right hand blades. Although each outside saw blade is sold separately, it is recommended to buy one set of both blades so the O.D. matches.

ADJUSTABLE WIDTH THIN KERF DADO SET

Carbide Tipped • 8" • 1/16" to 1/4" Groove • ATB Grind



Our 24 tooth adjustable width thin kerf dado set allows the user to cut precise dadoses from 1/16" to 1/4" wide. Set contains one split steel hub with a 5/8" bore and two different saw blades that when shims are added, enables you to achieve a variety of dado widths. The 1/16" blade #61381 will give you a minimum kerf of 1/16" (0.062") to a maximum of 1/8" (0.125") using shims, while the 1/8" blade #61382 will give you a minimum kerf of 1/8" (0.125") to a maximum of 1/4" (0.250") using shims.

System allows you to make thinner grooves on a table saw that previously could not be achieved with standard kerf dado sets.

Maximum groove depth (T) is 1-1/8".

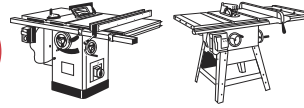
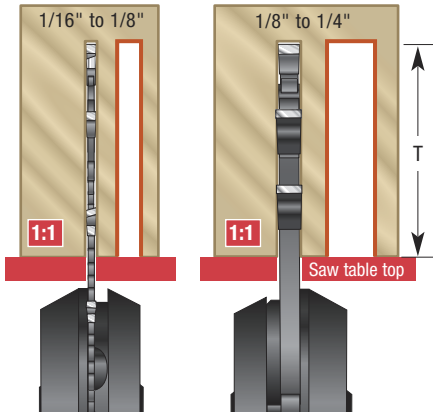

For 1/16" to 1/8" kerf use blade #61381 (included).



For 1/8" to 1/4" kerf use blade #61382 (included).



Excellent for:

- Hardwood
- Softwood
- Plywood
- MDF
- Chipboard

Very good for:

- Melamine



Shim set #DSS-106 & instruction booklet included.

ØD	Hook Angle	Teeth	ATB Angle	Grind	Kerf Range	Bore	T	Repl. Blade 1/16" Kerf	Repl. Blade 1/8" Kerf	Tool No.
8	-10°	24	15°	ATB	1/16 to 1/4	5/8	1-1/8	61381	61382	61380

Replacement parts: Flange #61387; Shim set #DSS-106; Screw #67157 (8); Hex key #5020 (included).

▲ Warning: This set requires a custom zero clearance throat plate.

▲ Warning: Not to be used with portable saws.

GROOVERS

Flat Top (FT) Grind • 12° Hook Angle

Designed to cut 1/4" grooves in solid wood and plywood on table saws and sliding table saws.

ØD	Teeth		'B' Kerf		'C' Plate		Max		Tool No.
	Inches	mm	Inches	mm	Inches	mm	RPM	Bore	
8	200	24	.250	6.35	.180	4.57	9,000	5/8	61365
10	250	24	.250	6.35	.180	4.57	7,600	5/8	61368



PLATE JOINTER

100mm

Designed with anti-kickback "fingers" that limit chip thickness to provide a safer cut without loss of cutting speed or quality. The blade fits most brands and models of plate jointers, including Lamello, Virutex, Freud, Kaiser, Elu, and DeWalt and other makes of plate-jointer machines. Packaged in a re-usable protective foam sleeve.

ØD	Teeth	Kerf	Bore	Tool No.
100mm	6	4mm	22mm	LAM400T6*

* Not for Porter Cable® 557



SPECIAL 'FACE-FRAME' PLATE JOINTER

Cut blind right-angle biscuit joints in stock as narrow as 1-3/4" with this smaller diameter blade that fits most biscuit jointers, including Lamello, Virutex, Freud, Kaiser, and DeWalt. A simple depth adjustment on your machine allows the use of this blade.

ØD	Description	Teeth	Kerf	Bore	Tool No.
3-1/16	Standard 'Face-Frame'	4	3mm	22mm	LAM300T4†

† LAM300T4 (22mm bore) will fit Lamello, Virutex, Freud, Kaiser, Elu, DeWalt and others.



▲ Warning: Before use, read saw blade safety guidelines on pages 312-314.

INDUSTRIAL



ACM ADJUSTABLE WIDTH DOUBLE EDGE V-SCORING SAW BLADE SET

Carbide Tipped • V-Groove with 2.0 (0.080") - 3.0mm (0.118") V-Flat Bottom

For 60°, 90°, 108° & 135° Folds

Designed for scoring Aluminum Composite (sandwich) Materials with 60°, 90°, 108° and 135° angle V-grooves with flat bottom. Set contains two saw blades and a shim set. Add the shims between the blades to achieve your desired flat bottom cut width. Widely used for cladding many diverse exterior and interior applications. The long lasting durability of the material makes it an excellent choice for buildings, signage, displays, etc.

ACM

Aluminum Composite Material
Saw Blades

Excellent for Scoring:

- Aluminum, Clay, Zinc & Wood Composite Panels
- Aluminum Composite Material (ACM)
- Aluminum Composite Panel (ACP)
- ALPOLIC® Copper Composite Material (CCM)
- Alucobond®
- Alupanel®
- Dibond®
- Durabond
- e-panel™
- Etalbond®
- TCM
- Trespa®

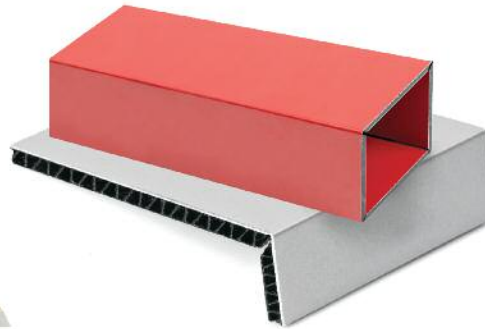
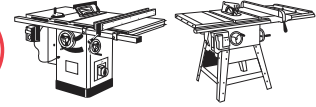

No Shim With Shims (included)

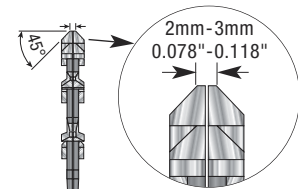
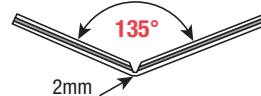
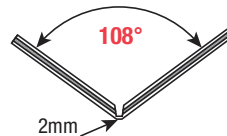
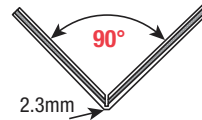
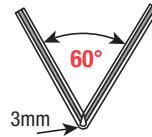

Flat Bottom Range

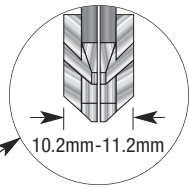
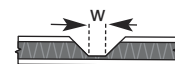

Kerf Range

ØD	Teeth	Hook Angle	Angle	B1	Grind	B=Kerf Range	W=Flat Bottom Range	Bore	Tool No.
8	2x20	18°	45°	0.161"	ACM	10.2-11.2mm	2.0-3.0mm / 0.078-0.118"	5/8	508400
8	2x20	18°	45°	0.161"	ACM	10.2-11.2mm	2.0-3.0mm / 0.078-0.118"	1	508400-1

Shim set #DSS-108 & instruction booklet included.

▲ **Warning:** This set requires a custom zero clearance throat plate.

▲ **Warning:** Not to be used with portable saws.



ACM Router Bits
See pages 6-7



ACM 90° DOUBLE EDGE V-SCORING SAW BLADE

With Replaceable Carbide Insert Knives

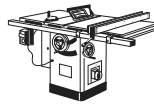

For 90°, 108° & 135° Folds

Designed for scoring Aluminum Composite (sandwich) Materials with 90° angle V-groove with flat bottom. Widely used for cladding many diverse exterior and interior applications. The long lasting durability of the material makes it an excellent choice for buildings, signage, displays, etc. Utilizes 4-sided carbide inserts.

For Scoring Aluminum Composite Materials Including:

- Aluminum, Clay, Zinc & Wood Composite Panels
- Aluminum Composite Material (ACM)
- Aluminum Composite Panel (ACP)
- ALPOLIC® Copper Composite Material (CCM)
- Alucobond®
- Alupanel®
- Dibond®
- Durabond
- e-panel™
- Etalbond®
- Phenolics
- Plastic/Acrylic
- Plexiglas®
- TCM
- Wood

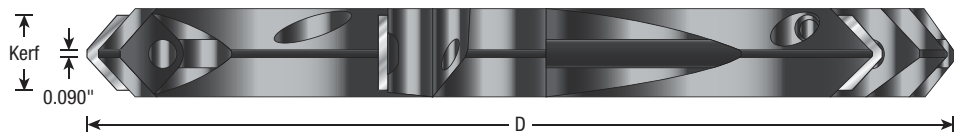
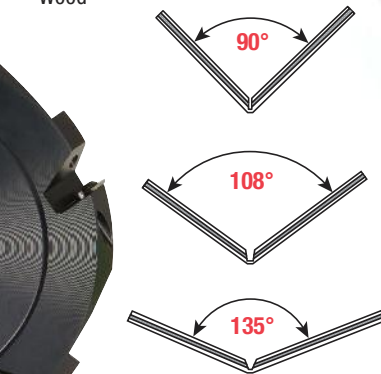
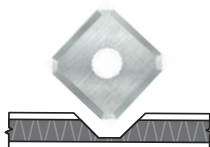

ØD	Teeth	Angle	Kerf	Flat Bottom Width	Bore	Repl. Knife	Repl. Knife	Tool No.
6	5	90°	25/64	0.090"	5/8	—	RCK-48	RC-4304 <i>New</i>
7-1/4	5	90°	37/64	0.090"	5/8	RCK-47	—	RC-4300

Replacement parts: Screw #67115 (5); Torx® key #5005 (included).

Warning: This set requires a custom zero clearance throat plate. Not to be used with portable saws.

Warning: Before use, read saw blade safety guidelines on pages 312-314.



Combination
Rip/Crosscut

GENERAL PURPOSE

Alternate Top Bevel (ATB) Grind • Positive Hook

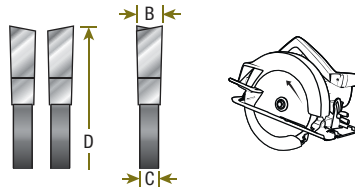

This carbide-tipped trim-saw blade is the ideal upgrade (or replacement blade) for Makita and other brands of portable trim saws. The alternate top bevel grind ensures high-quality crosscuts in solid wood and sizing cuts in plywood.

ØD	Teeth	'B' Kerf	'C' Plate	Bore	Tool No.
5-3/8 / 5-1/2	30	.072	.052	5/8 **	RM-550

** Fits Makita 5-1/2" saw and others.

Comes with two adapter bushings, one for 1/2" arbor and one for 10mm arbor.

Replacement bushing: #BU-110 (5/8 x 1/2), #BU-125 (5/8 x 10mm).

BUSHINGS & STABILIZERS available, see next page.



Acrylic & Non-Melt Plastic

PLYWOOD & PLASTIC CUTTING

Triple Chip (TC) Grind • Positive Hook

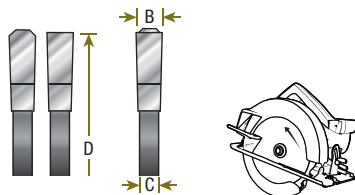

This blade produces quality cuts when sizing plywood and other sheet goods with a portable circular saw. The blade can also be used for cutting plastics.

ØD	Teeth	'B' Kerf	'C' Plate	Bore	Tool No.
7-1/4	40	.120	.078	5/8♦	PC-620

♦ Denotes 5/8" arbor with diamond knock-out.



Demolition
Emergency

NAIL-CUTTING & DEMOLITION

Flat Top (FT) Grind • 5° Negative Hook

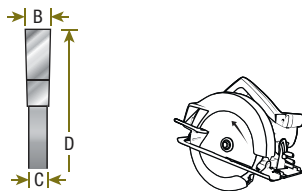

This blade is designed especially for renovation and demolition work, where contact with nails, screws, and similar debris has to be expected. The blade is configured – low tooth count and flat-top grind – for ripping. A negative hook angle and strong shoulder design to help prevent the blade's carbide tips of breaking off upon impact against a hidden nail.

ØD	Teeth	'B' Kerf	'C' Plate	Bore	Tool No.
7-1/4	14	.120	.078	5/8♦	NC-820

♦ Denotes 5/8" arbor with diamond knock-out.

HIGH PRECISION SAW BLADE BORE REDUCTION BUSHINGS

Made in Germany

ØD	Ød	B	Tool No.
5/8	10mm	.053	BU-125
5/8	1/2	.060	BU-110
3/4	5/8	.062	BU-150
20mm	3/8	.060	BU-120
20mm	1/2	.062	BU-123
20mm	5/8	.062	BU-124
22mm	3/4	.062	BU-130
22mm	20mm	.070	BU-140
1	5/8	.086	BU-100
1	7/8	.097	BU-225
1	7/8	.110	BU-250
1	3/4	.075	BU-200
1	20mm	.097	BU-122
1-1/8	1	.086	BU-300
1-1/4	1	.086	BU-400
1-1/4	1-1/8	.075	BU-500
1-1/4	30mm	.086	BU-450
30mm	5/8	.070	BU-515
30mm	3/4	.070	BU-520
30mm	25mm	.070	BU-530
30mm	1	.070	BU-525

Note: Most saw blade bushings have serrations on the outside diameter edge to provide a better grip and fit.

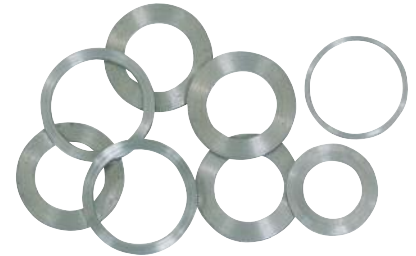
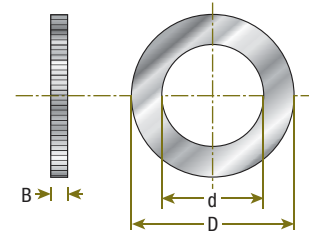

SAW BLADE STABILIZER / STIFFENER

The purpose of blade stabilizers is to increase the overall stiffness of the saw blade, thus reducing vibration. Reduction in vibration improves cut quality and dampens noise. Stabilizers are particularly beneficial when used with thin-kerf blades. Amana Tool® stabilizers are made from the steel used for our Industrial Series saw blades. The steel is ground (not stamped), and it is extremely flat on both sides to reduce run-out and vibration. Please note that depth of cut will be reduced slightly and interference between the stabilizers and the table insert may occur. You may use one or two stabilizers, depending on the application and arbor length.

Each order number consists of one pair.

ØD	Ød	B	Use With Saw Blade		Tool No.
			Diameter(s)		
4	5/8	.098 (x2)	8 to 12		STF-4
4	30mm	.100 (x2)	8 to 12		STF-4-30
6	1	.100 (x2)	14 to 20		STF-6

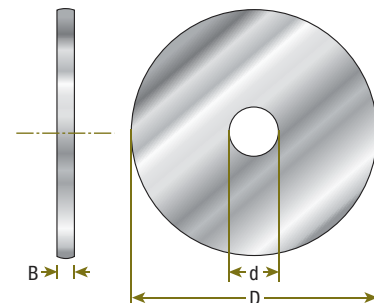
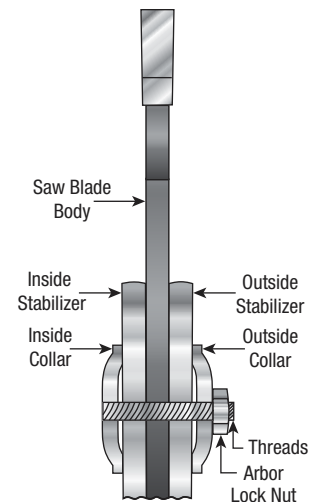

RE-BORING SERVICE

Most Amana Tool® saw blades, scoring saws and dado sets can be re-bored to fit special size arbors.

Note: For special boring requests (pin-holes, keyways, etc.) please visit www.amanatool.com/reboring.pdf for a detailed drawing to show bore specifications and arrangement.

Guarantee: Blades carry the same Amana Tool® quality guarantee. However, blades are not returnable once re-bored except for defects in material or workmanship.

Important Note: Due to the many different size scoring saw arbors on the market, please order carefully.

For example: If you were to assume that the arbor hole needed was 1-3/16" (1.187") and it was actually 30mm (1.181"), the difference of only .006" (6/1000th of one inch) is enough that the blade would not fit onto the arbor properly. (1-3/16" is too large to fit on 30mm arbors and will have excessive vibration and run-out and will not run concentrically.) Conversely, if the arbor hole is **too small**, you could do damage to the arbor, blade and tensioning if you attempt to **force** the blade onto the arbor.

GENERAL INFORMATION

1. TOOTH CONFIGURATIONS

Flat Top (FT)

Used on saw blades for cutting soft and hardwood along the grain (ripping).



Alternate Top Bevel (ATB)

Alternate right top bevel and left top bevel. Used on saw blades for general purpose and crosscutting natural wood and veneered plywood.



Alternate Top Bevel Modified (H-ATB)

Higher top bevel grind and longer tooth than our standard alternate top bevel. Used on 'MB' and 'MSB' Series blades and are specifically designed for cutting melamine chip-free on table saws without the aid of scoring units.

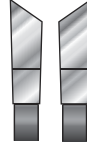

Combination Tooth (4 + 1)

Groups of four alternate top bevel and one flat ground tooth, divided by large gullets in the saw plate. Used on combination blades for general purpose wood applications.

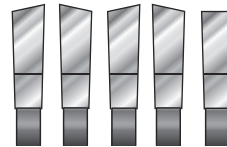

Triple Chip (TCG)

Alternate flat raker tooth and higher trapeze tooth divides the chips to achieve cuts in hard materials, MDF, OSB and plastics. Also used on blades for cutting non-ferrous materials.

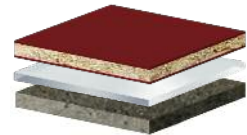
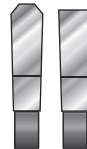

California Triple Chip (C-TCG)

For use in miter saws in picture frame shops, window and door manufacturers or anywhere that miter machines are used.

Produces burr-free cuts in non-ferrous materials as well as splinter-free cuts in wood and wood-based products.

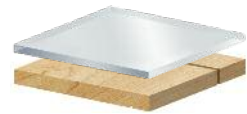
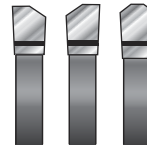

Cone Form (Conical)

Used on conical tooth scoring blades.

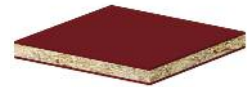

Hollow Ground (HG)

Hollow face grind is used for cutting melamine and other difficult to machine materials. Generally used on vertical panel saws (Striebig, etc.).



GENERAL INFORMATION

2. TOOTH ANGLES

Hook (Rake) Angle 6° to 22°

Soft materials or rip blades require an angle of about 18° to 22°, hard materials about 6°. Saw blades for cutting aluminum and melamine have a negative hook angle.

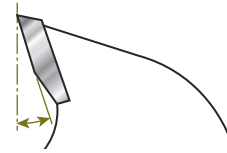

Top Clearance Angle 12° to 15°

This angle changes according to the hardness of material; 12° for hard and 15° for softer materials.

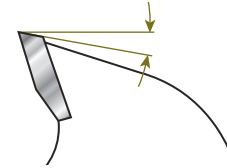

1. Top Bevel Angle 8° to 12°

Normally 10°, enabling gradual penetration into material.

2. Radial Side angle 1° to 2°

Allows clearance along the sides of the tooth.

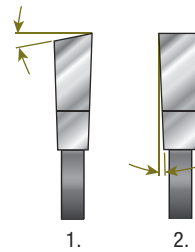

3. GENERAL

Kerf ('B')

Refers to the largest width of the saw tooth and is represented in decimals and/or millimeters.

Plate ('C')

Refers to the thickness of the steel saw body, on to which the carbide teeth are brazed. This dimension is represented in decimals and/or millimeters.

Note: Most industrial series saw plates are laser cut.

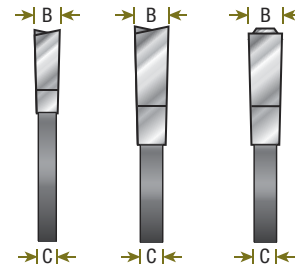

Expansion Slots

Allows the saw body to expand and contract under load and heat and to prevent twisting or warpage.

Copper Plugs

Reduces the turbulent noise created by the saw blade while it is being operated.

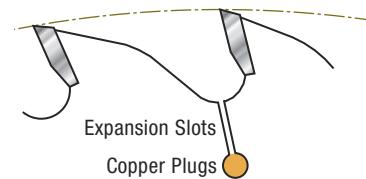

Bore, Pin-Holes, Keyways

Refers to the diameter of the arbor hole, pin-holes, keyways, etc., and is represented in fractions or millimeters.

Note: P.H. denotes pin-hole configuration, if applicable.
Example: 2/10/60 = 2 @ 10mm dia. on 60mm circle.

Note: A special re-boring service and bushings are available for non-standard sizes.
Please see page 309.

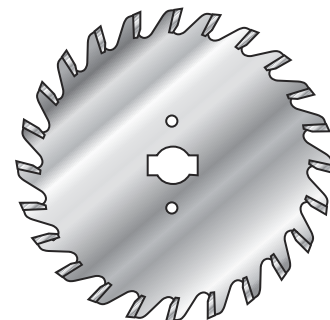

Safety Guidelines for saw blades



1. Always refer to your power tool owner's manual.



2. Always wear eye and ear protection during operation of power tools.



3. Disconnect the power tool from the power source before changing the saw blade.



4. Never cut stock freehand. Always use the fence or miter gauge to support the work-piece.



5. Keep your hands out of path of the saw blade.



6. Always feed the stock against the direction of the power tool rotation.

SAFETY GUIDELINES *For Saw Blades*



- 7.** Do not use a blade that is cracked or broken, has a chipped or missing tooth, or has been dropped or damaged.



- 8.** When mounting the saw blade, saw teeth must face the direction of power tool rotation.



- 9.** Make certain that the arbor nut is secure before starting the saw.



- 10.** Never exceed maximum RPM of the saw blade. Each blade may differ; please see blade stencil.



- 11.** Do not attempt to cut screws, nails, staples, concrete or other foreign materials. Use saw blade only for which it was intended.



- 12.** Never make adjustments to the saw while the blade is spinning.



- 13.** Use a splitter or riving knife to prevent kickback.



- 14.** Before starting the saw, adjust the saw blade height 1/8" above the work-piece.





15. Always use the guard that came with the saw.

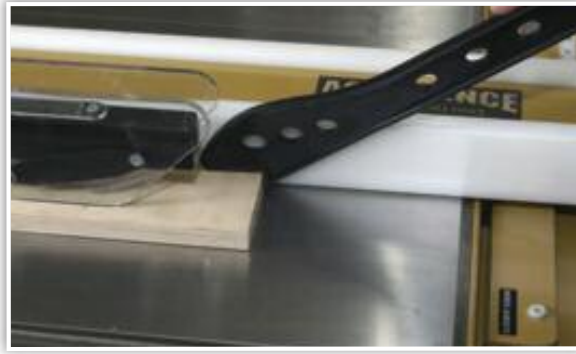

16. Use a push stick to distance your hands from the blade when ripping narrow stock.



17. Allow saw to reach maximum RPM before starting the cut.



18. Make certain the work-piece is supported before starting the saw.

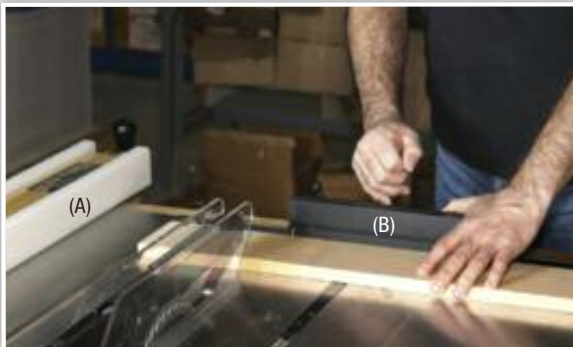

19. Never use fence(A) and the guide(B) at the same time. Do not force the blade into the cut. Use a feed rate that does not bog down the saw.



20. Use roller stands to support the large work-piece.



21. Have your saw blade professionally sharpened and inspected.



22. Keep the saw blade sharp and clean.