

REVISIONS	
DATE	DESCRIPTION

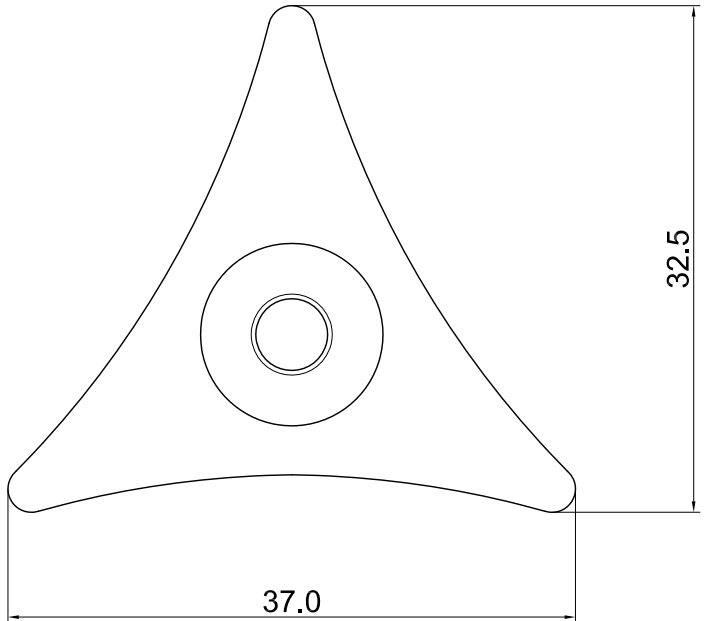
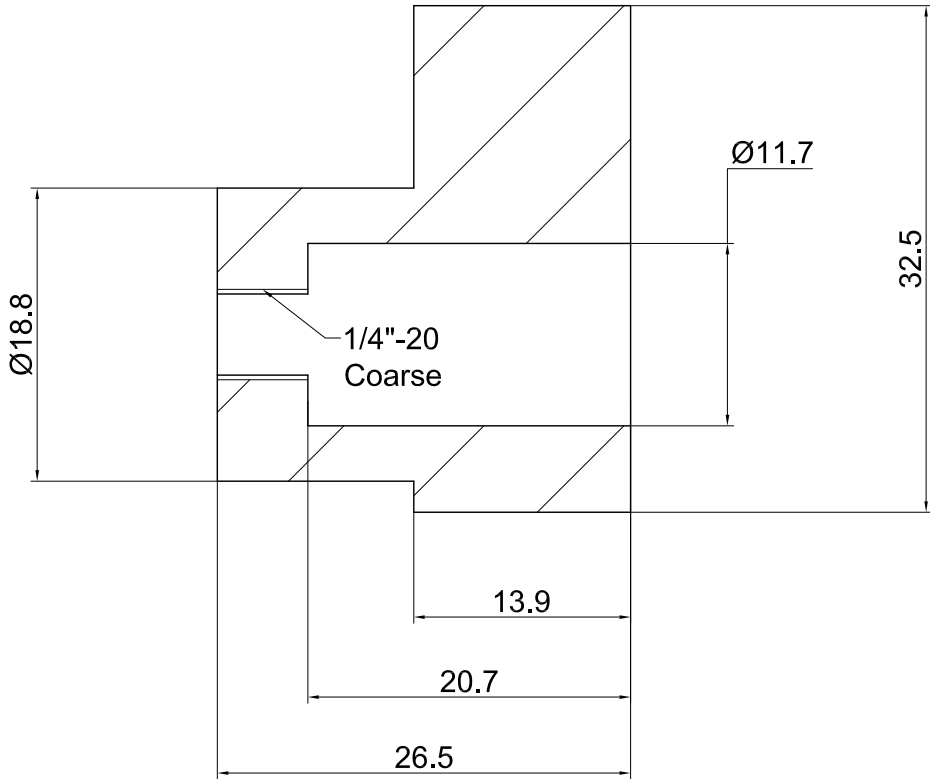

DIMENSIONS ARE IN mm

TOLERANCES

- FRACTIONAL ±
- ANGULAR: MACH BEND ±
- ONE PLACE DECIMAL ±
- TWO PLACE DECIMAL ±

MATERIAL:
 FINISH:
 WEIGHT (GR):

RICHELIEU HARDWARE

ITEM # KN00112
 1-1/2" 3-star Insert Knob

SIZE A	DWG. NO.
------------------	----------

DATE 2021.01.19	REV.	SHEET 1 OF 1
--------------------	------	--------------