

	"A"	"B"
MIN	11.875 [301.6]	4.00 [101.6]
MAX	18.500 [469.9]	9.875 [250.8]

PART NUMBER	FINISH
VR12-CR	CHROME
VR12-SN	SATIN NICKEL
VR12-ORB	OIL RUBBED BRONZE

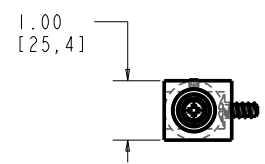
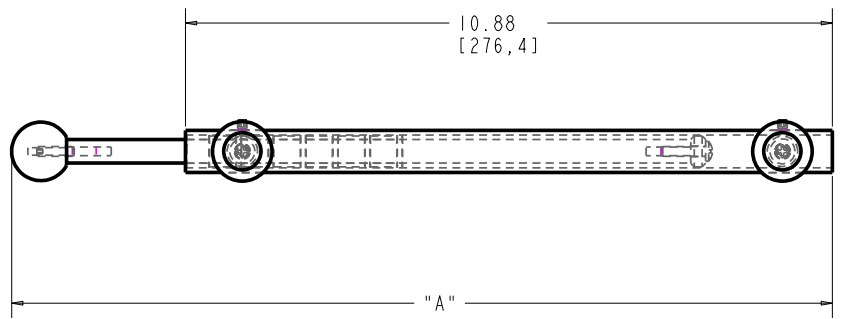
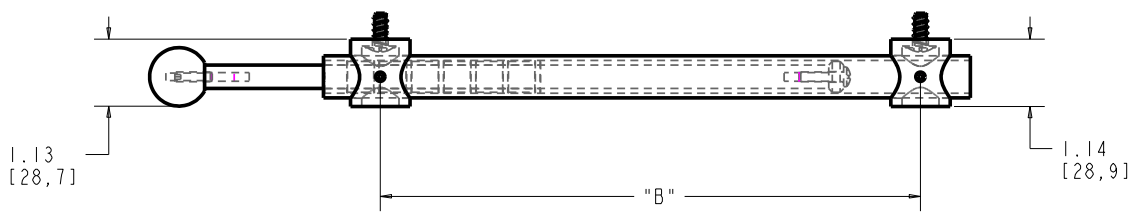

CUSTOMER DRAWING

This drawing is the property of Rev-A-Shelf (RAS) and is disclosed in confidence to the extent its subject matter is original to RAS. Any vendor receiving this drawing from RAS shall hold and use this drawing for the sole benefit of RAS and shall not disclose it to, or use or reproduce it for any third party, or perform any act adverse to the interest of RAS with respect to this drawing without the express written permission of RAS. Vendors shall not revise any physical, dimensional or performance characteristic unless authorized by Rev-A-Shelf Engineering.

REV.	DATE	BY	DESCRIPTION OF CHANGE

INCH [MM]	AMERICAN PROJECTION	BY	DATE	REV-A-SHELF, Inc.
		DRAWN	PFC 9/5/08	
TOLERANCES				SIZE
DECIMALS .XX ±.02 [.5mm]				B
ANGLES ±1/2°				MATERIAL
.XXX ±.005 [.13 mm]				WILD STEEL
FRACTIONS ±1/32 [.8 mm]				FINISH
SEE NOTES				DRAWING NO.
				VR-12-CUSTOMER
				SCALE
				1:2
				PART NO.
				VR-12-XX
				SHEET
				1 OF 2