

CABINET DIMENSIONS

CABINET DIMENSIONS

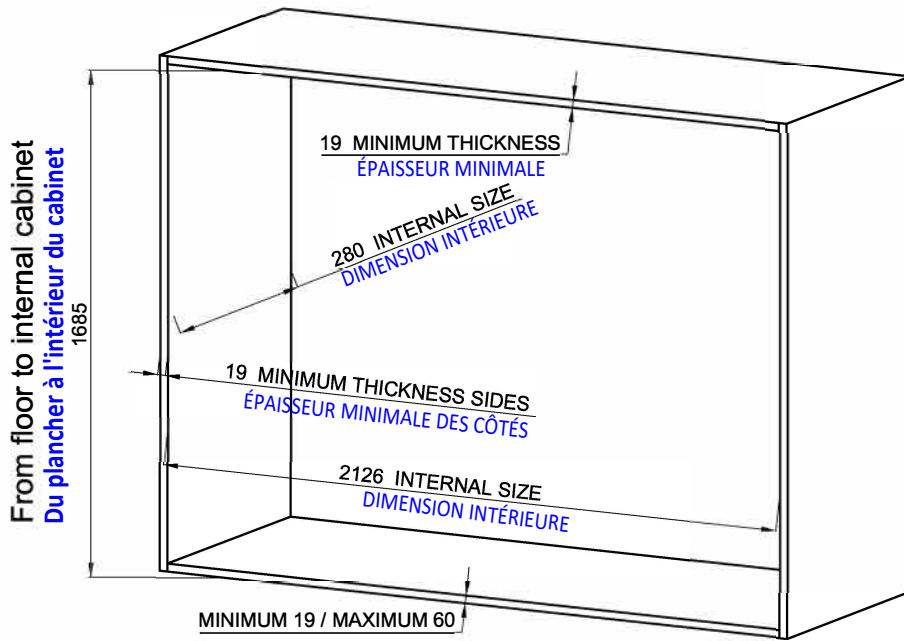

EXEMPLE AVEC MATELAS 180 MM D'ÉPAISSEUR

Si l'épaisseur du matelas diffère de l'exemple:
 - X (hauteur de votre matelas) - 180 mm = Y
 - Nouvelle profondeur du cabinet = 280 mm + Y
 - Si l'épaisseur du matelas > 305 mm SVP contacter le service à la clientèle

EXAMPLE with mattress 180mm

if change the mattress thickness:

- X (your mattress height) - 180mm = Y
- new depth cabinet = 280mm + Y
- if mattress thickness > 305mm contact customer service

HOLES ON SIDE PANEL FOR METAL PLATES

TROUS SUR LE PANNEAU LATÉRAL POUR LES PLAQUES EN MÉTAL

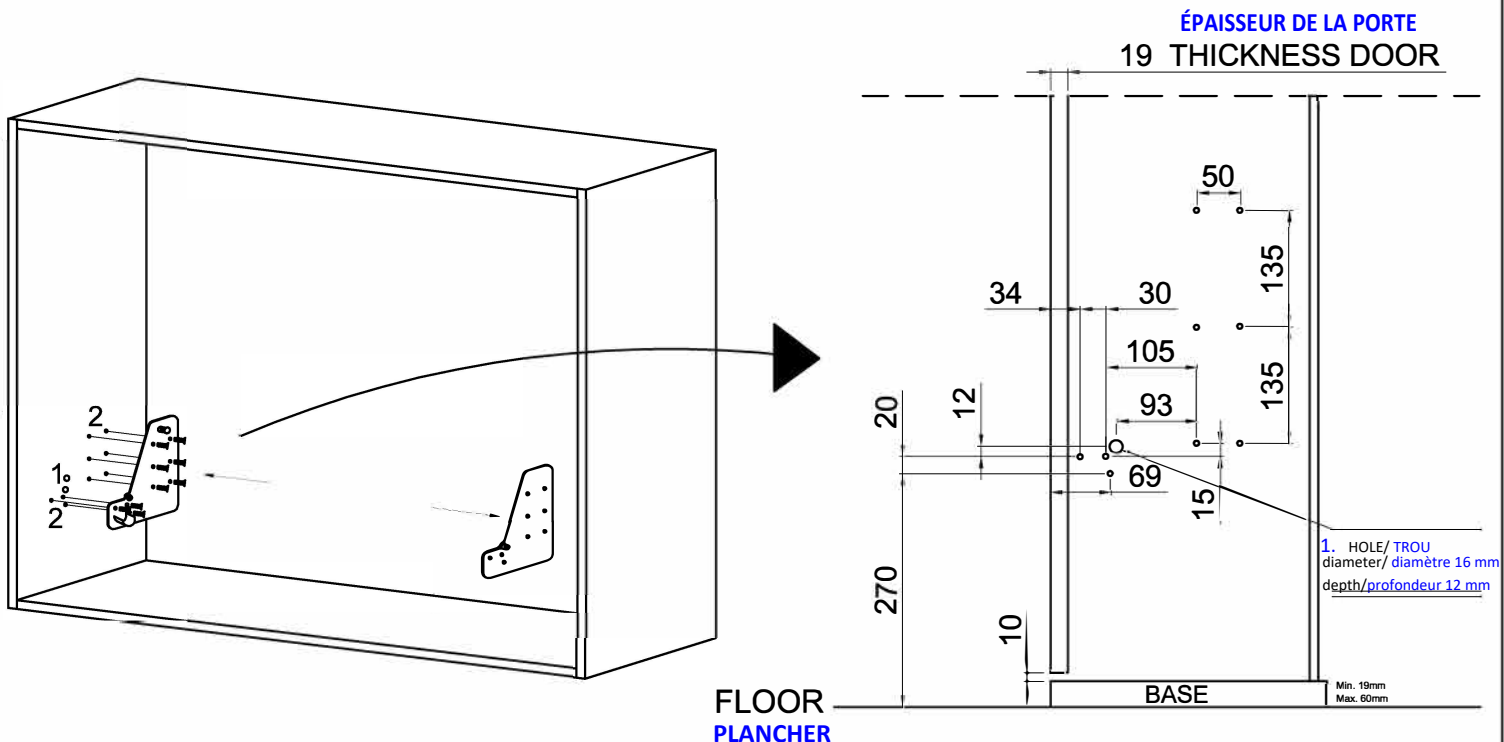

- 1 HOLE/TROU Ø 16 MM DEPTH/PROFONDEUR 12 MM
 - 2 COMPASS 6MA
- HOLES/ TROU Ø8mm DEPTH/ PROFONDEUR 17mm

Page	Page 1 of 3	Sizes	mm	Date
Article		ART. 8410016		

HOLES AND DIMENSIONS OF FRONT PANEL

TROUS ET DIMENSIONS DU PANNEAU AVANT

SIDE VIEW
VUE DE CÔTÉ

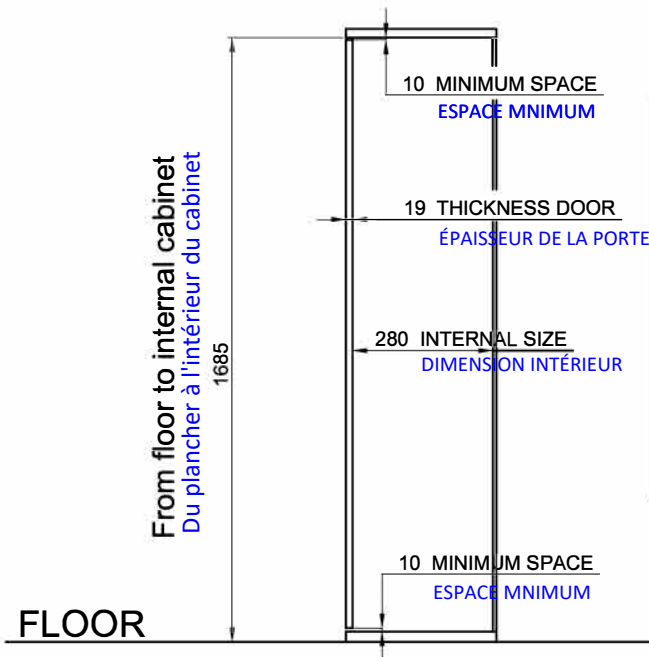

FRONT PANEL DIMENSION

As the thickness of base of cabinet can be from 19mm to 60mm, YOU NEED TO DETERMINATE the door dimension as follow:

1685 minus 10, minus 10 (minimum space) minus thickness of your cabinet base

DIMENSION DU PANNEAU AVANT

Comme l'épaisseur de la base du cabinet peut varier de 19 mm à 60 mm, VOUS DEVEZ DÉTERMINER la dimension de la porte comme suit:

1685 moins 10, moins 10 (espace minimum) moins l'épaisseur de la base de votre cabinet

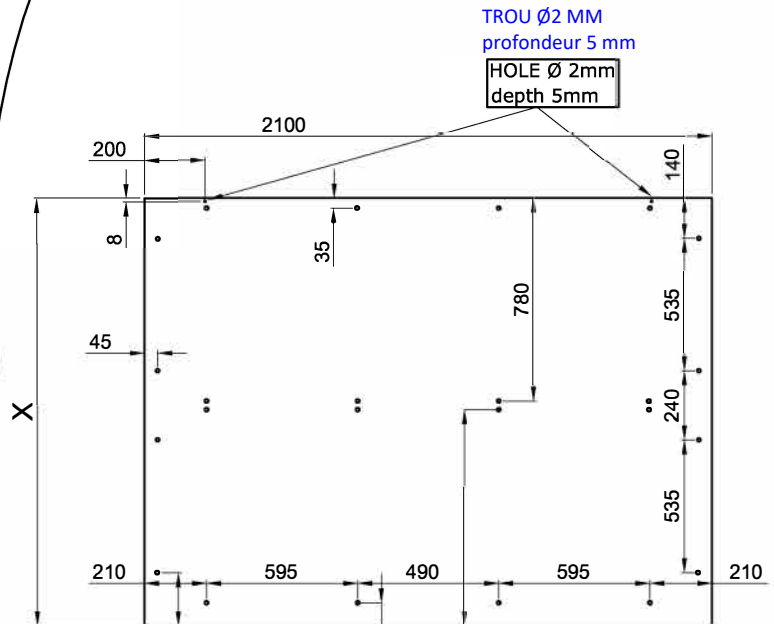
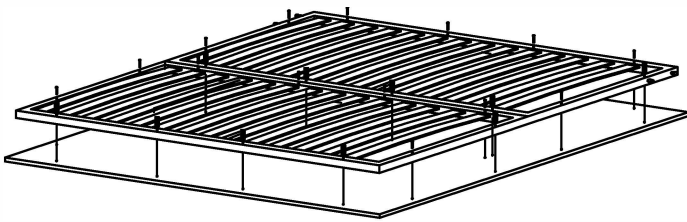

215 DETRACT DIMENSION BASE CABINET

DIMINUER LA DIMENSION DE LA BASE DU CABINET

110 DETRACT DIMENSION BASE CABINET

DIMINUER LA DIMENSION DE LA BASE DU CABINET

855 DETRACT DIMENSION BASE CABINET

DIMINUER LA DIMENSION DE LA BASE DU CABINET

COMPASS 6MA

TROU/ HOLE Ø 8mm

profondeur/depth 17mm

Page	Sizes	Date
Page 2 of 3	mm	
Article	ARTG. 8410016	

TUBE 20x20 and MAGNETS
TUBE 20 X 20 ET AIMANTS

