

# COCKTAIL

**ART. 4119312010**



# COCKTAIL - WHAT'S IN THE BOX?/ COMPOSANTES



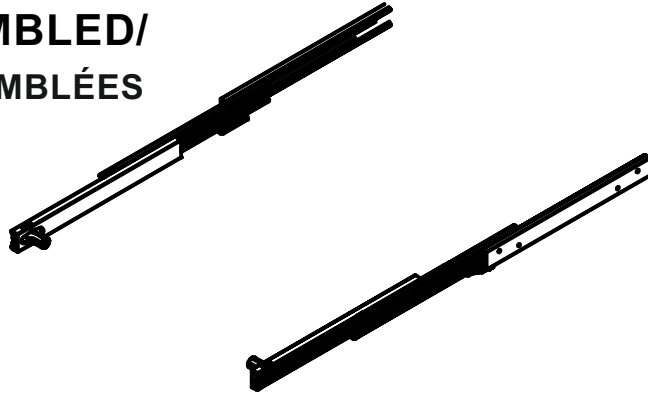

**(2x) SLIDES ASSEMBLED/  
COULISSES ASSEMBLÉES**



**(1x) FRONTBAR  
BARRE FRONTALE**

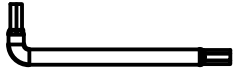

## HARDWARE SET/ QUINCAILLERIE

- A -**  **#5 ALLEN KEY (1x)**
- B -**  **M6x60 (4x)**
- C -**  **EURO SCREWS 6X13 (8X) / VIS EURO 6X13 (8X)**
- D -**   **M6 BRASS BUSHINGS (4x) / BOULONS EN LAITON (4X)**

# REQUIRED CABINET INTERNAL DIMENSIONS / DIMENSIONS INTERNES DU CAISSON REQUISES

## INTERNAL DIMENSIONS/ DIMENSIONS INTERIEURES

WIDTH/ LARGEUR:	410 - 1170 mm (16 9/64" - 46 1/16")
DEPTH/ PROFONDEUR:	min. 540 mm (21 17/64")
HEIGHT/ HAUTEUR:	min. 120 mm (4 23/32")
PANEL THICKNESS/ ÉPAISSEUR DU PANNEAU:	19 mm(3/4")

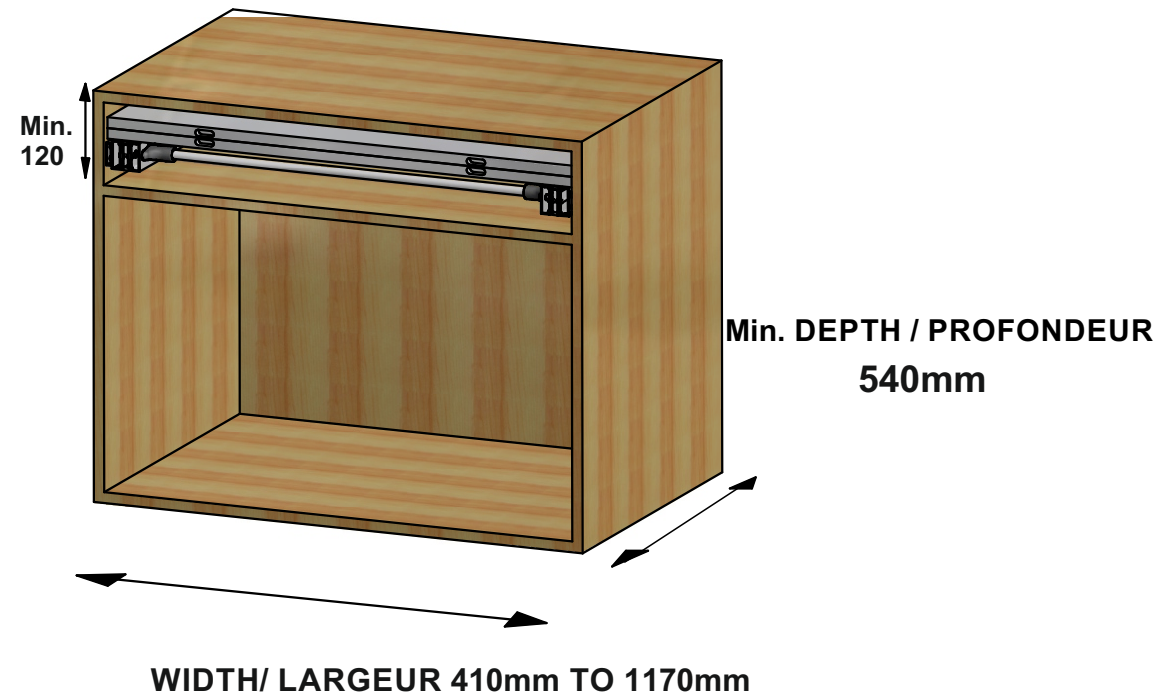
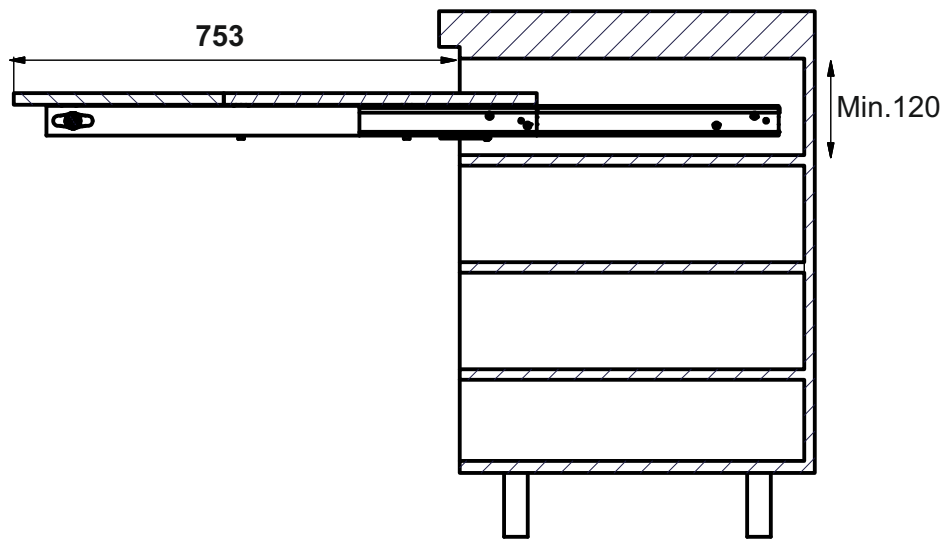

# HOLES DRILLING LOCATION FOR SLIDES MOUNTING / POSITION DE PERÇAGE POUR LE MONTAGE DES COULISSES

**DRILL 4 HOLES ON EACH SIDE OF CABINET(DIAM. 5x13) /  
PERCER 4 TROUS SUR CHAQUE CÔTÉS DU CAISSONS( DIAM.5X13)**

**K:** POSITION OF HOLES TO FIX THE SLIDES  
POSITION DES TROUS POUR FIXER LES COULISSES

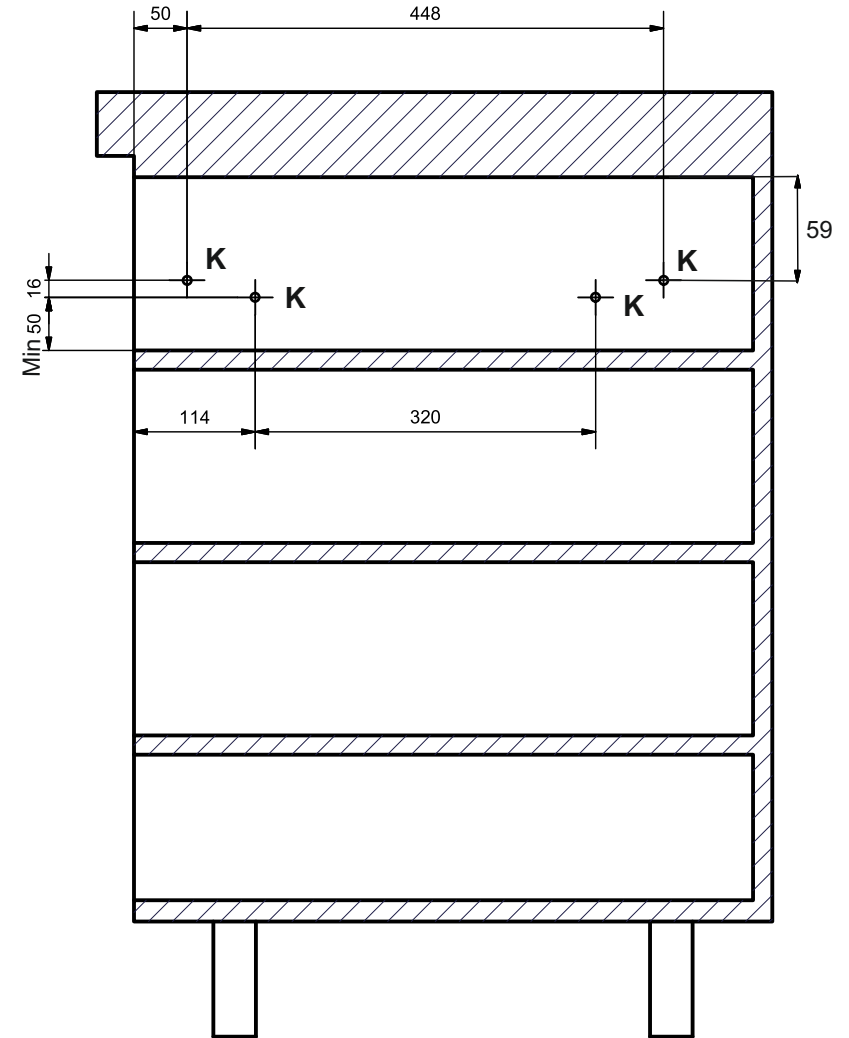

# FRONT BAR - HANDLE ASSEMBLY / ASSEMBLAGE DE LA BARRE- POIGNÉE FRONTALE

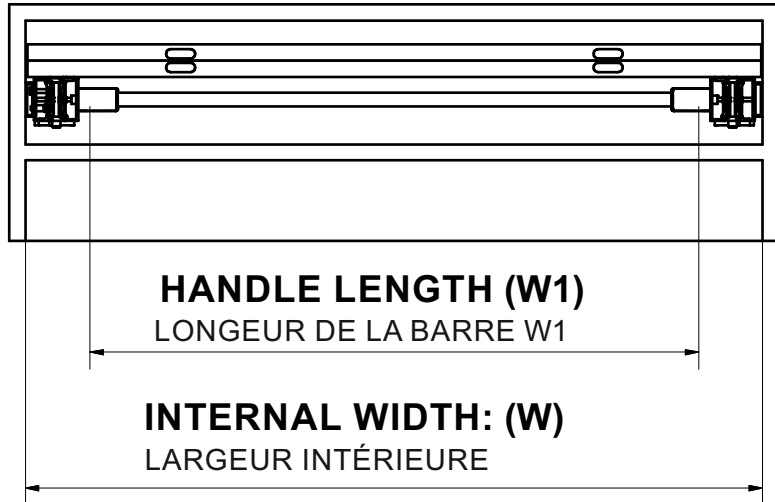

**CUT TO SIZE THE FRONTAL BAR**

$$W1 = W - 165\text{mm}$$

**COUPER LA BARRE À DIMENSIONS REQUISES**

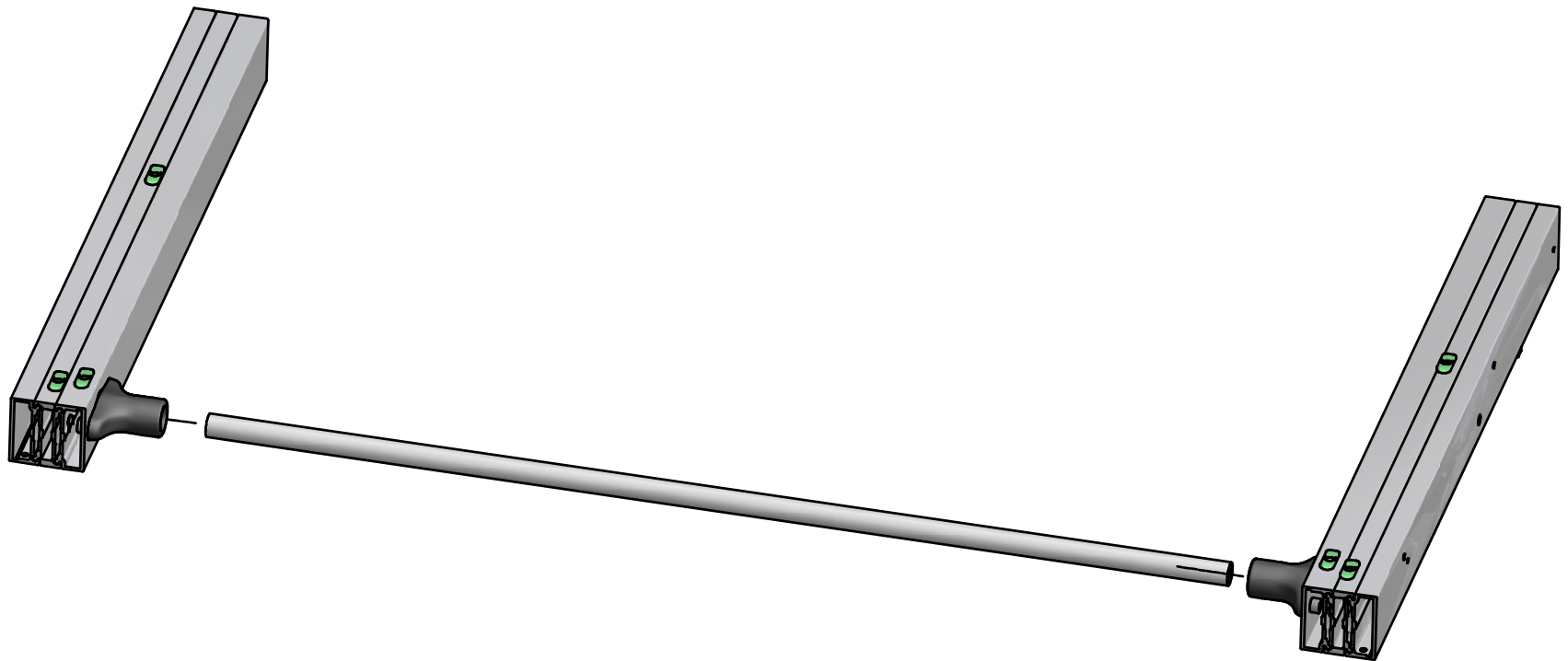

# MOUNTING OF THE MECHANISM ON THE CABINET

## INSTALLATION DU SYSTÈME COULISSANT

1

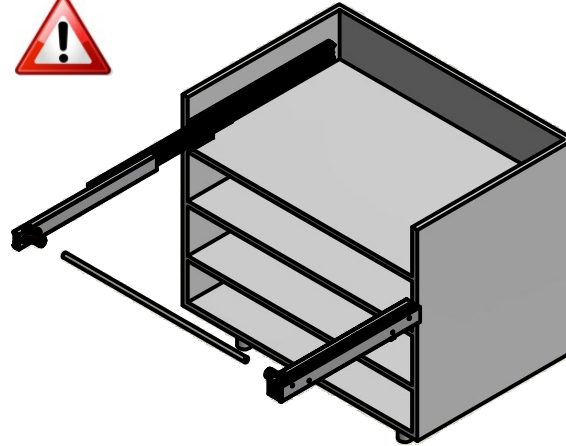
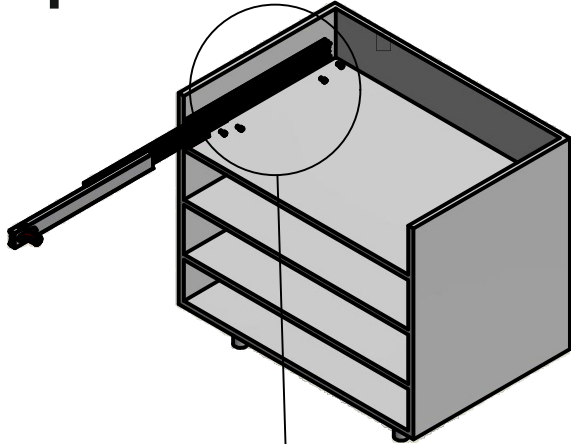

2. INSERT THE FRONT BAR IN EACH MECHANISM.

INSÉREZ LA BARRE DANS LE SYSTÈME COULISSANT

C.EURO SCREW 6X13 / VIS EURO 6X13

3

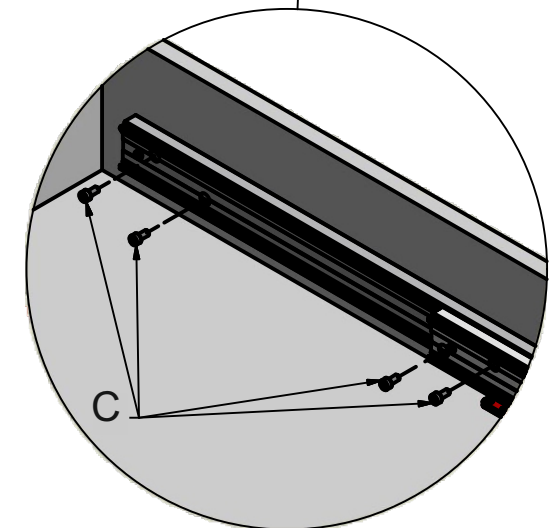
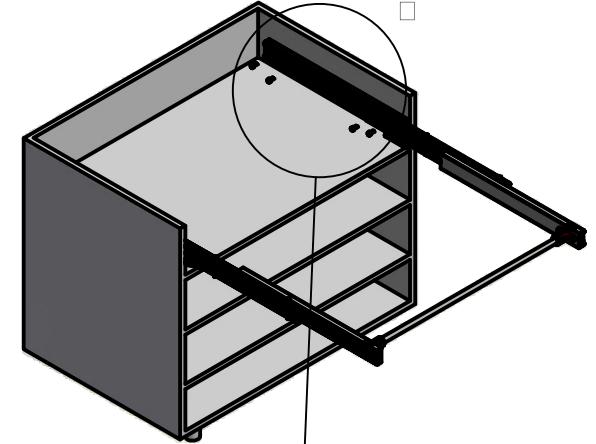

# TABLE TOP DIMENSION / DIMENSIONS DES PANNEAUX

## BOTTOM VIEW / VUE DU DESSOUS

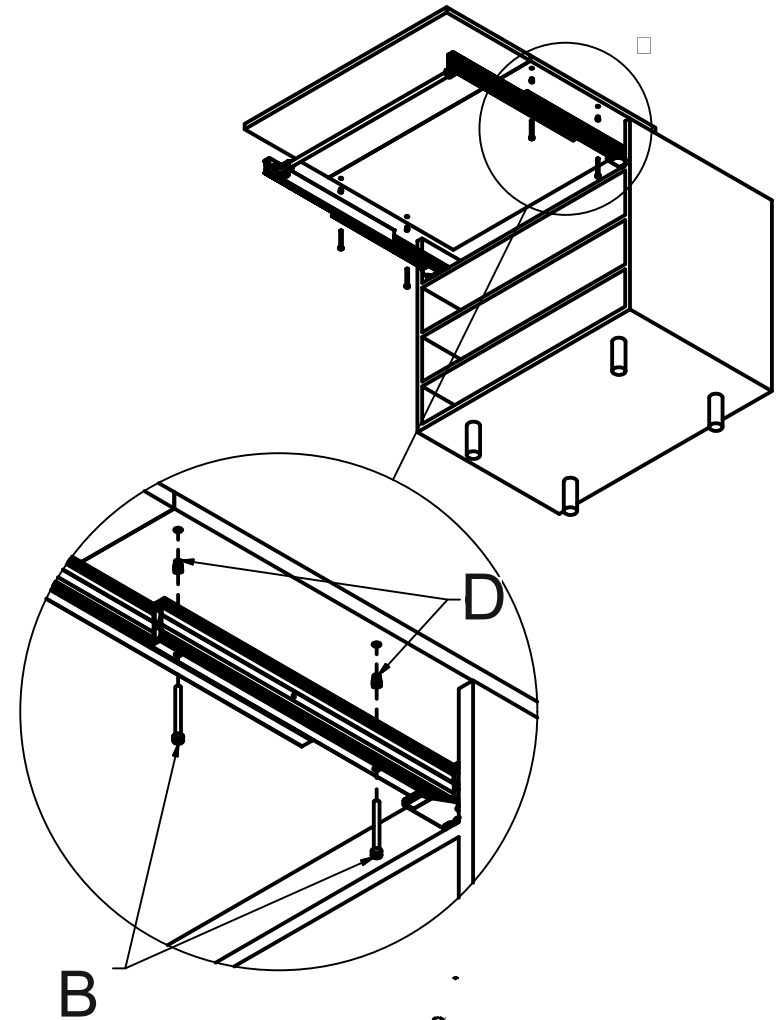
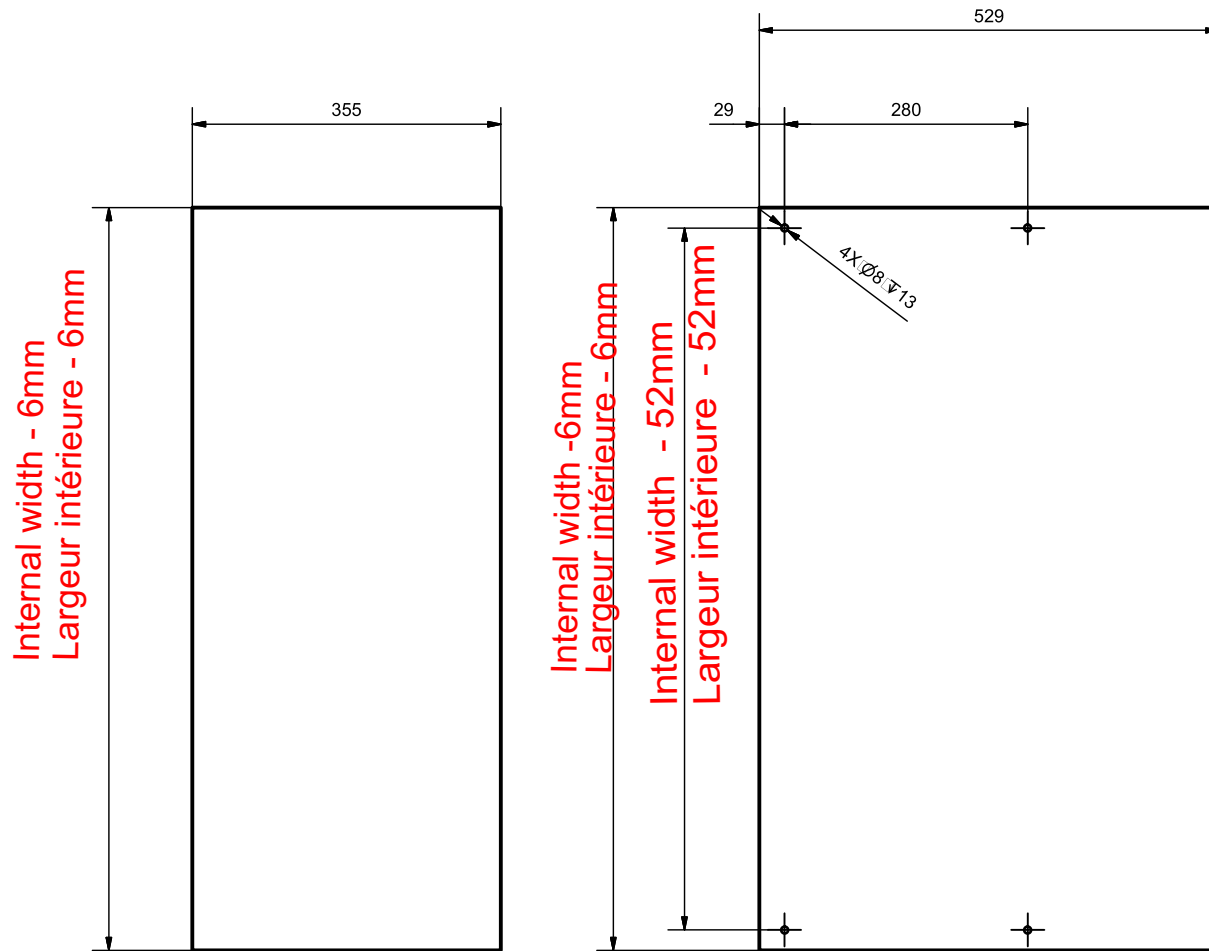

A -  #5 ALLEN KEY (1x)

B -  M6x60 (4x)

D -  M6 BRASS BUSHINGS (4x)  
M6 BOULONS EN LAITON (4X)

# MILLING FOR HINGES / PRÉPARATIONS POUR CHARNIÈRES

**ONLY If you use hinges item # 411933002G**  
**(Set/3 Sold separately)**

**SEULEMENT si vous utilisez le set/3 charnières #411933002G**  
**(vendu séparément)**

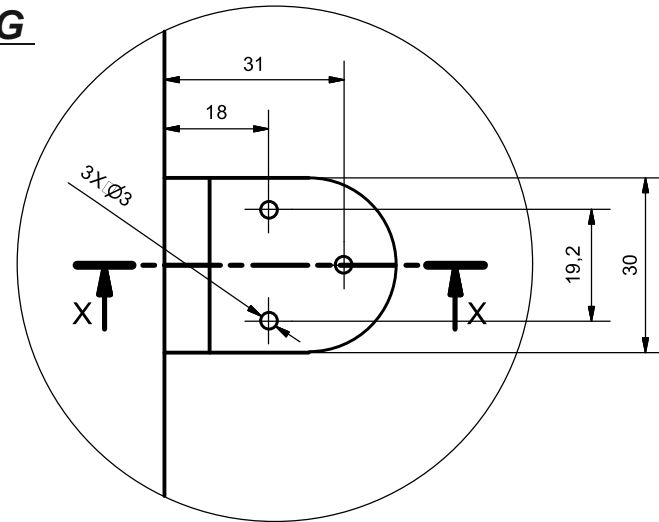
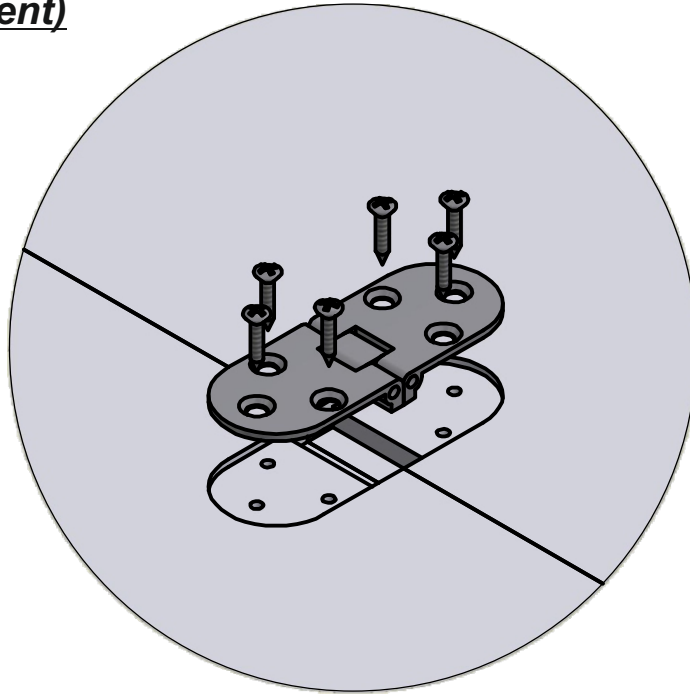

**3,5 x 14 mm COUNTERSINK WOOD SCREWS**  
**VIS A BOIS À TÊTE FRAISÉE 3.5X14MM**

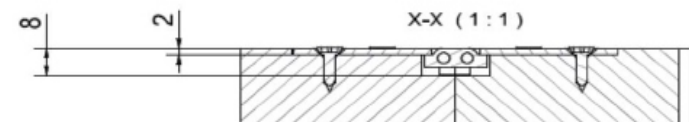
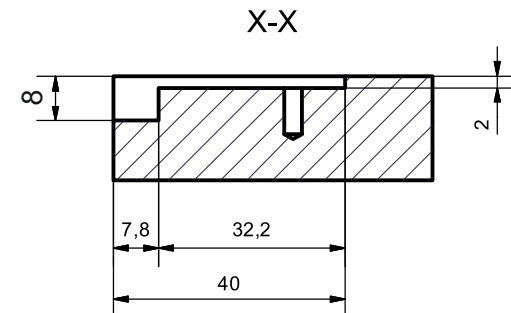



# TABLE TOP DRILLING / PERÇAGE DU PANNEAU

TOP VIEW  
VUE DE HAUT

L = INTERNAL WIDTH - 6 mm

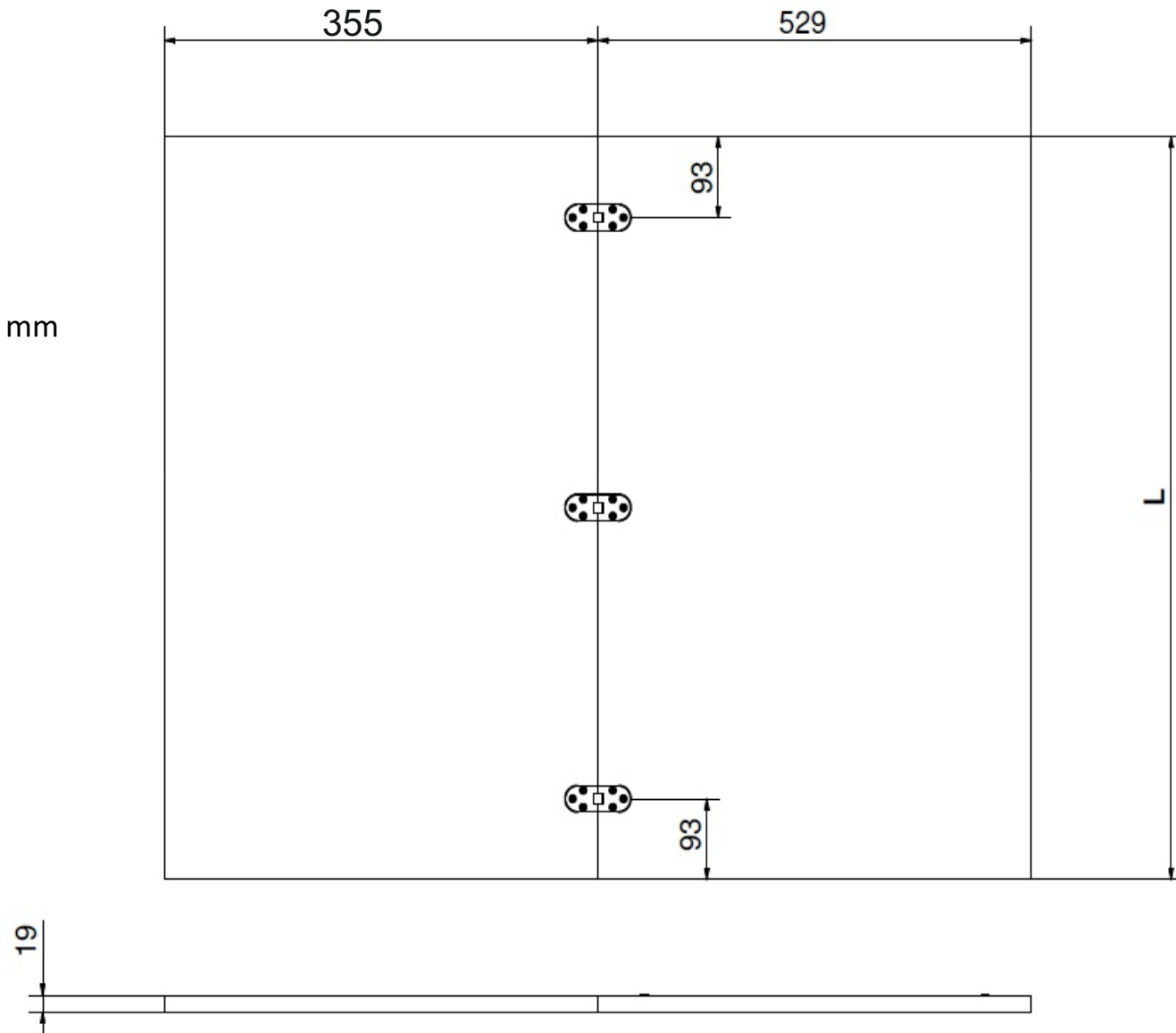

# MILLING FOR HINGES / PRÉPARATIONS POUR CHARNIÈRES

**ONLY If you use hinges item # 411932002G**  
**(Set/3 Sold separately)**

**SEULEMENT si vous utilisez le set/3 charnières #411932002G**  
**(vendu séparément)**

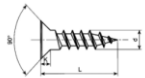
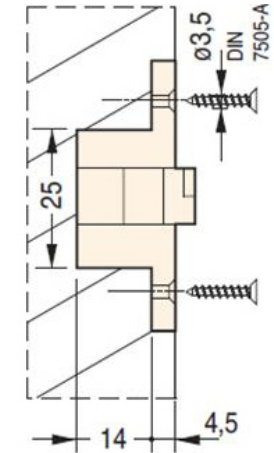
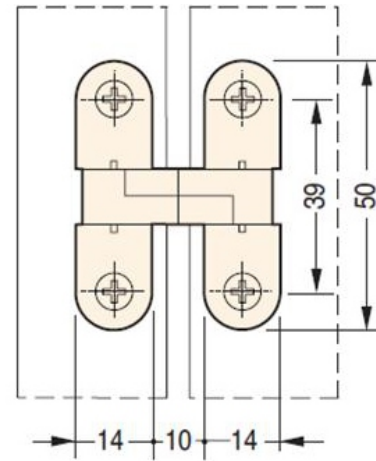

WOOD SCREW COUNTERSINK  
3,5 X 30

VIS A BOIS À TÊTE FRAISÉE  
3.5X30mm

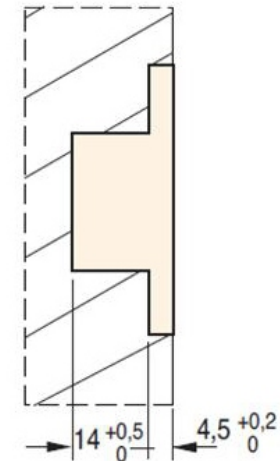
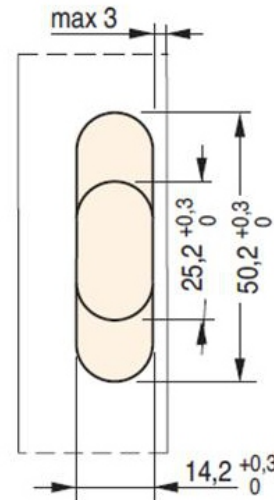

# TABLE TOP DRILLING / PERÇAGE DU PANNEAU

## TOP VIEW

VUE DE HAUT

L = INTERNAL WIDTH -6 mm

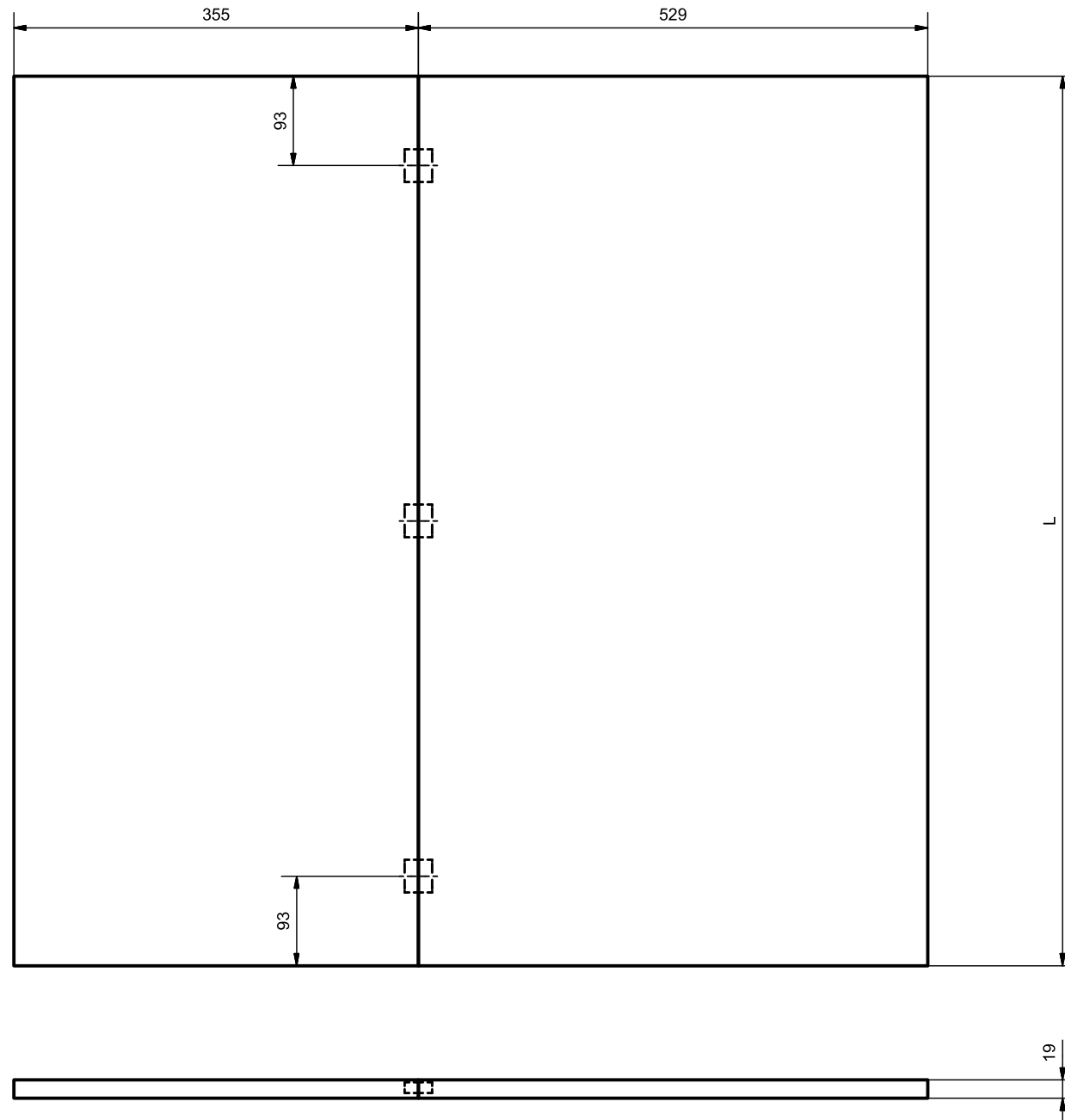

# FRONTAL DOOR HINGE / CHARNIÈRES POUR PANNEAU FRONTAL

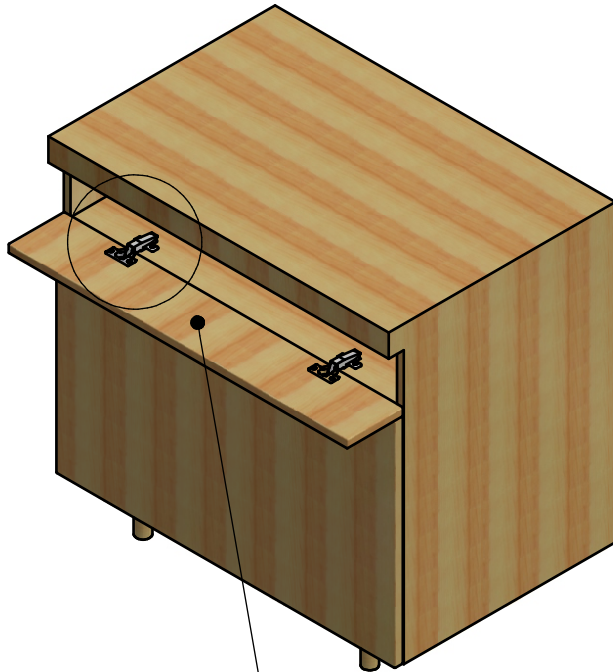

**FRONTAL DOOR HINGE**  
**CHARNIÈRES POUR PANNEAU FRONTAL**  
( Sold separately / vendu séparément )

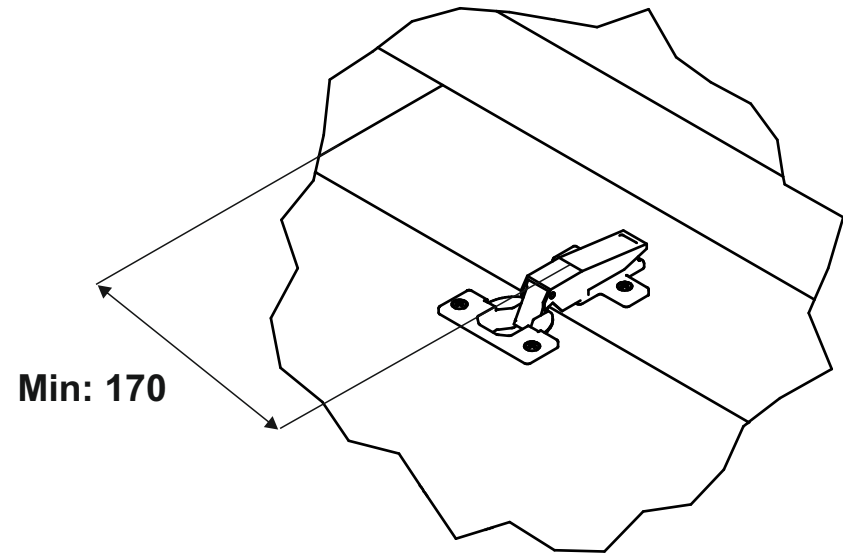

Min: 170

CLOSED / FERME'

OPENED / OUVERT

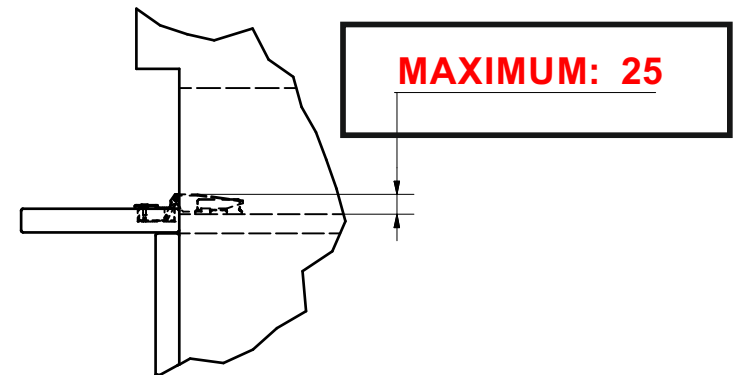
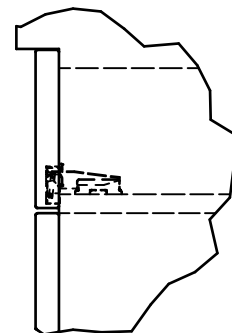

**MAXIMUM: 25**

# FUNCTIONING STEPS / ÉTAPES DE FONCTIONNEMENT

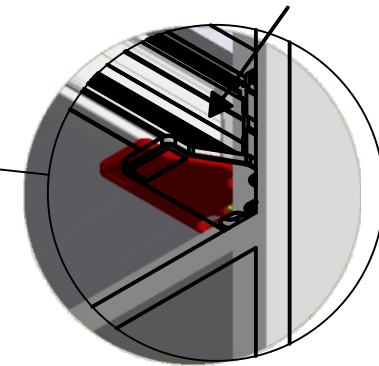
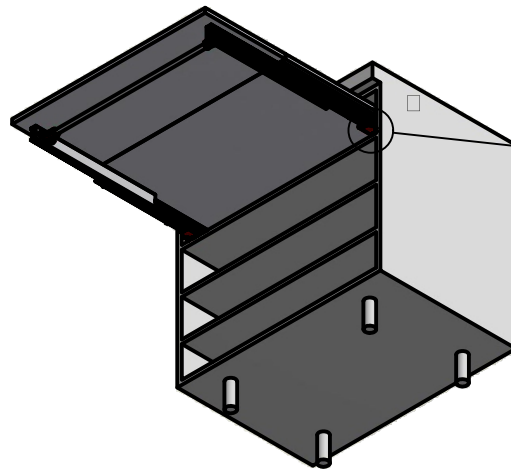
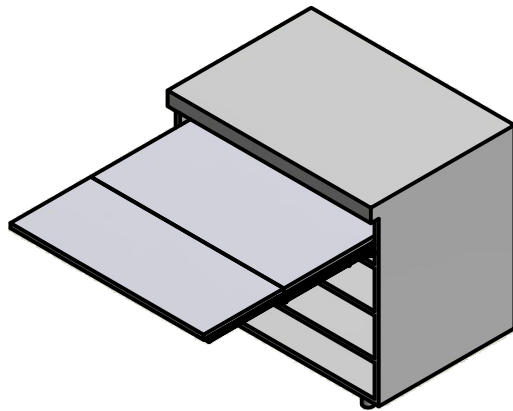
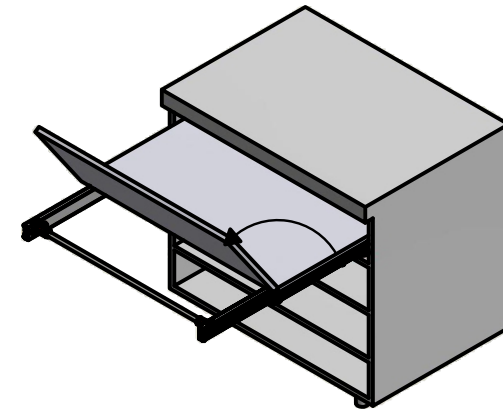
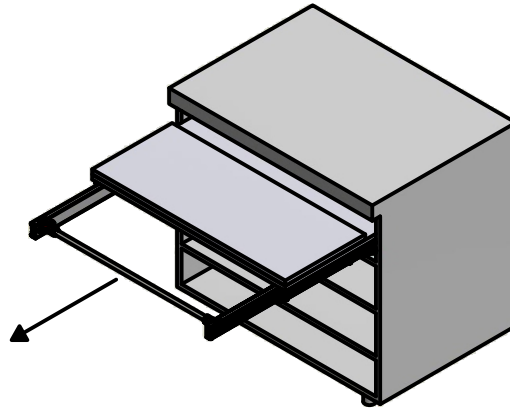
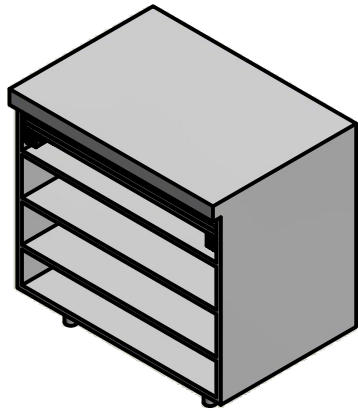

**TO CLOSE THE MECHANISM  
PUSH-IN THE 2 RED LOCKING TABS ON EACH SIDE**

**POUR FERMER LE MÉCANISME, POUSSER LES 2  
BARRURES ROUGE VERS L'INTÉRIEUR**