

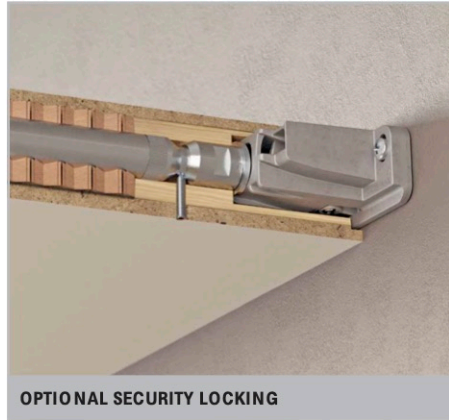

TRIADE PRO XXL

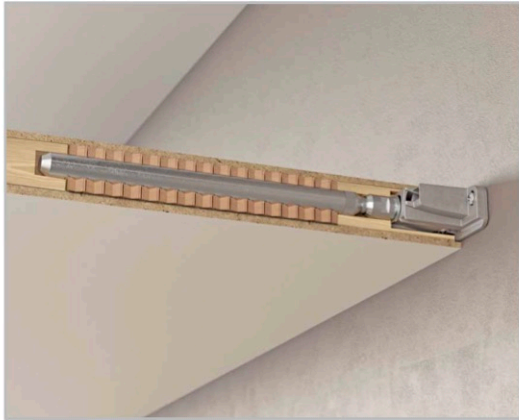

OPTIONAL SECURITY LOCKING

40 mm min. 

40 kg per pair
for shelf 400 mm deep 

SPECIFICATION

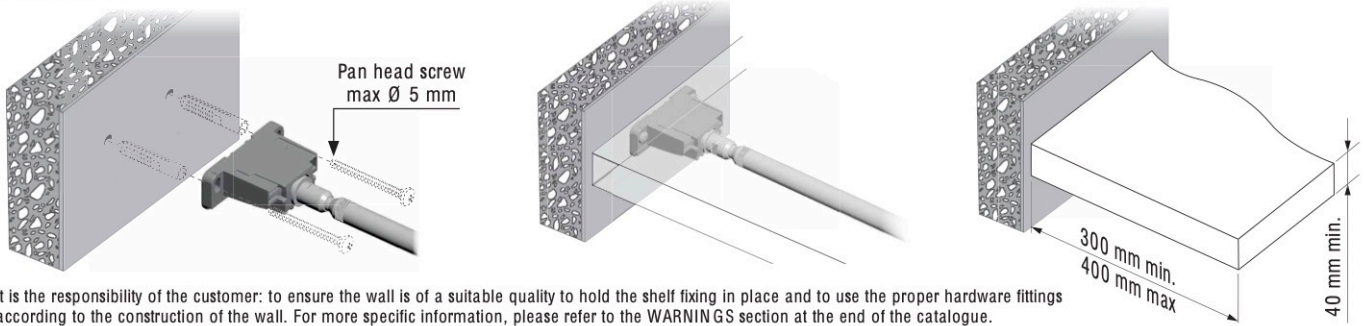

It is the responsibility of the customer: to ensure the wall is of a suitable quality to hold the shelf fixing in place and to use the proper hardware fittings according to the construction of the wall. For more specific information, please refer to the WARNINGS section at the end of the catalogue.

ADJUSTMENT

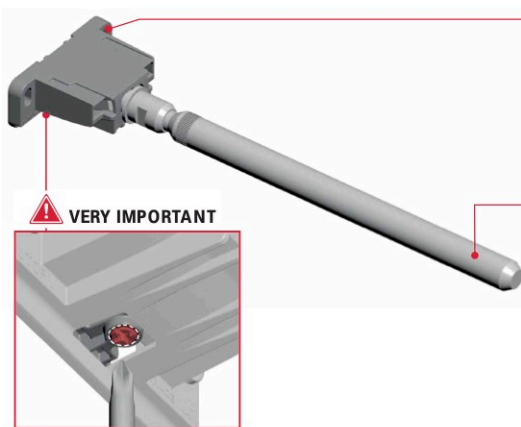

VERY IMPORTANT

Screw to lock when adjustments are finished.

BRACKET ALIGNMENT

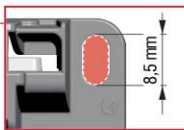

LATERAL ADJUSTMENT

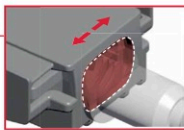

INCLINATION ADJUSTMENT

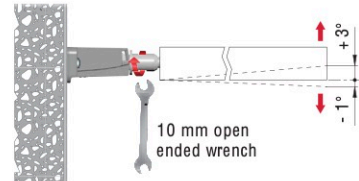
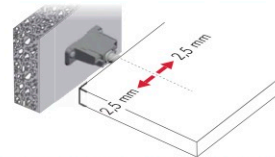
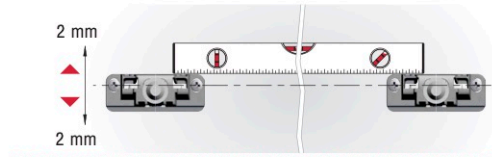
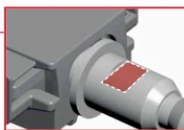

CAPACITY LOADING CHART

(The figures refer to 2 shelf supports)

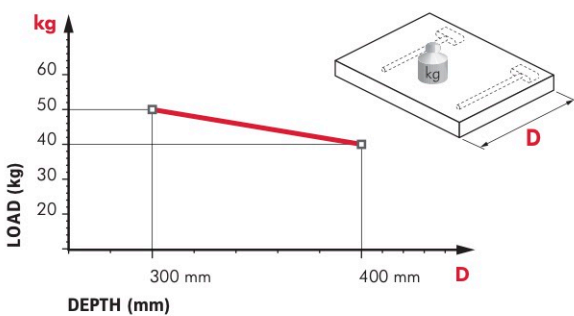

RECOMMENDED NUMBER OF TRIADE PRO XXL PER SHELF

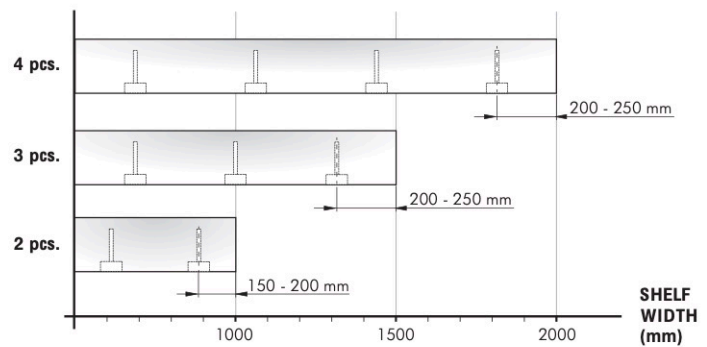

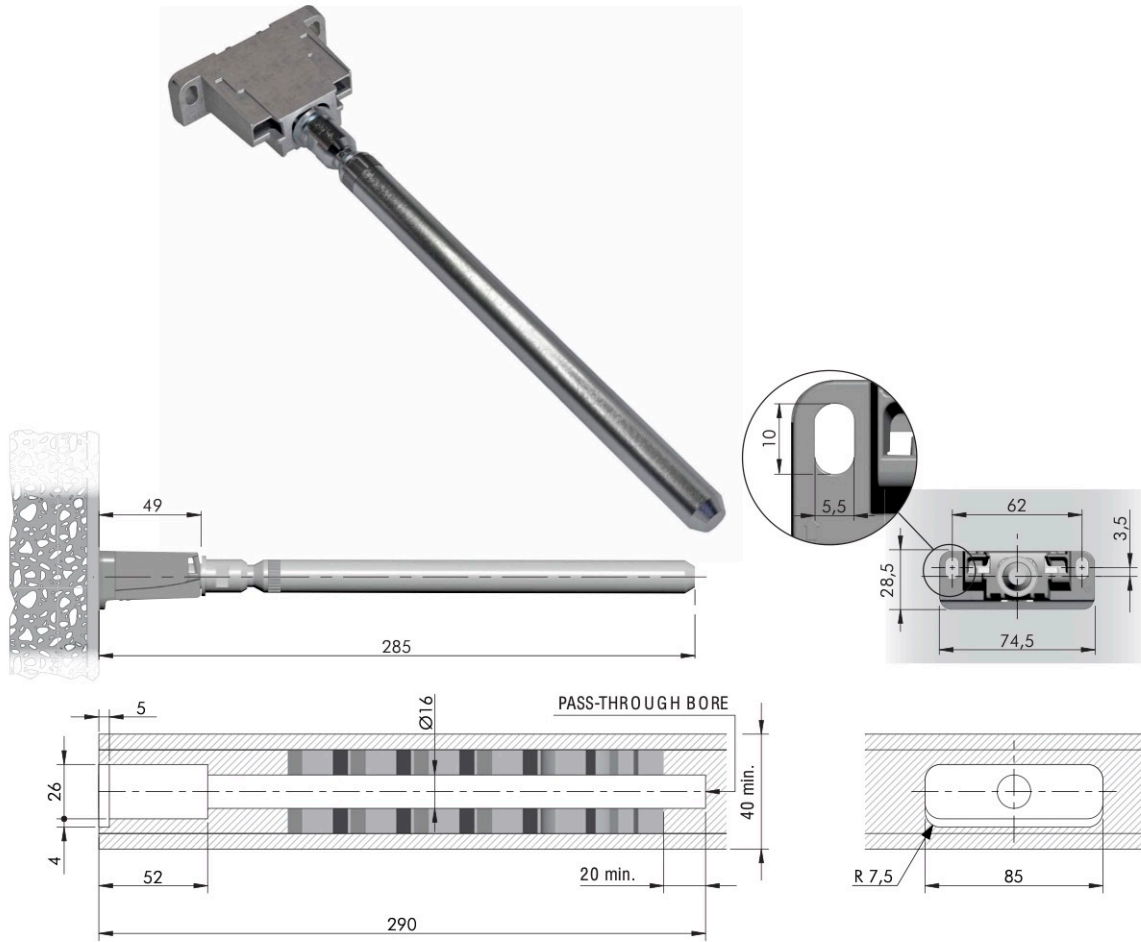

VERY IMPORTANT
 Centre of the hole is shifted 3,5 mm upwards. Please keep in mind when levelling the shelf.