

Item	DWG NO	Quantity	DIMENSIONS ARE IN mm TOLERANCES FRACTIONAL ± ANGULAR: MACH ± BEND ± ONE PLACE DECIMAL ± TWO PLACE DECIMAL ±	NAME	DATE	Richelieu Hardware		
1	Handle	1	MATERIAL: Steel	DRAWN		RICHELIEU /VENDOR ITEM NUMBER 246207020090		
2	Washer	1		CHECKED				
3	Knob	1	FINISH: Black	ENG APPR.		SIZE	DWG.NO.	REV.
4	Knob	1		MFG APPR.		A	Handle	0
5	Washer	1	WEIGHT(GR): 800.95	Q.A.		DO NOT SCALE DRAWING		SHEET 1OF 1
6	Washer	2		COMMENTS:	1			
7	Screw	2						

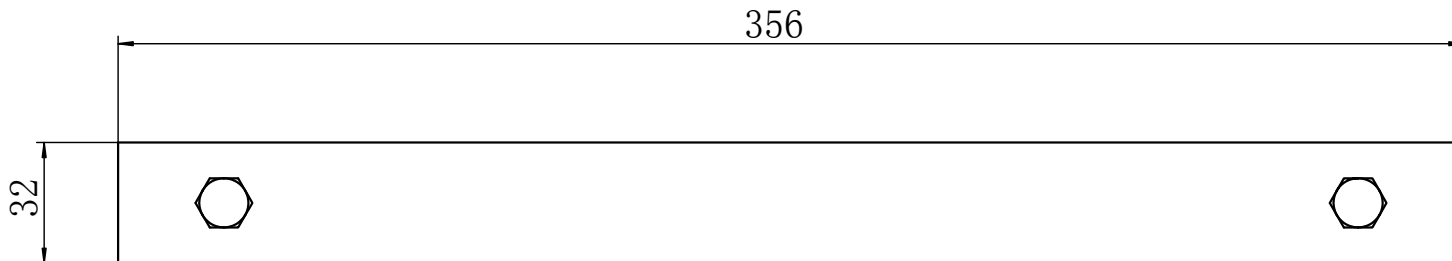

DIMENSIONS ARE IN mm TOLERANCES FRACTIONAL ± ANGULAR: MACH ± BEND ± ONE PLACE DECIMAL ± TWO PLACE DECIMAL ±		NAME	DATE	Richelieu Hardware		
	DRAWN					RICHELIEU /VENDOR ITEM NUMBER 246207020090
	CHECKED					
	ENG APPR.					
	MFG APPR.					
	Q.A.			SIZE	DWG.NO.	REV.
MATERIAL: Steel	COMMENTS:		A		Handle	0
FINISH: Black	1-1		DO NOT SCALE DRAWING		SHEET 1 OF 1	
WEIGHT(GR): 612.75						

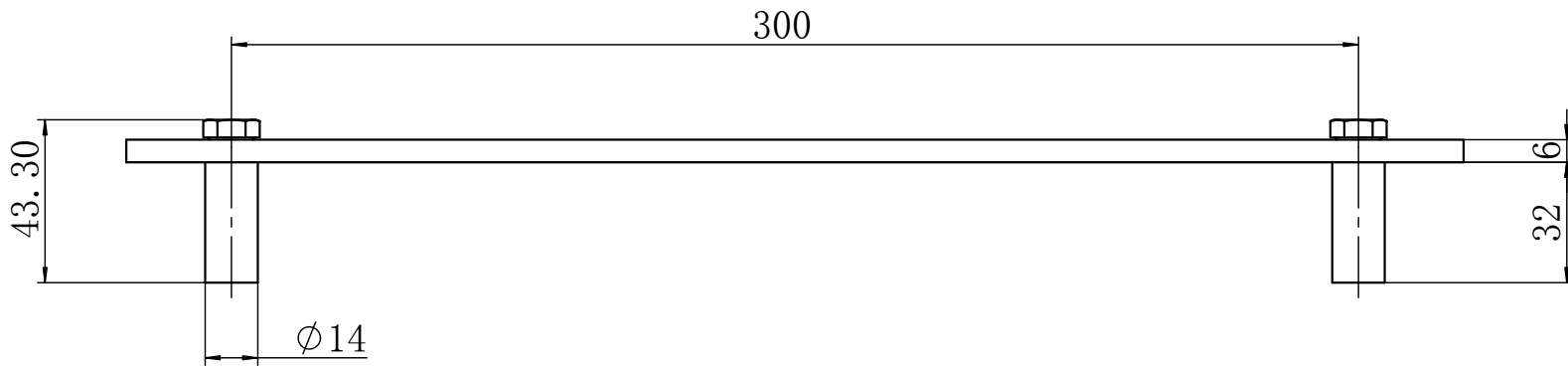
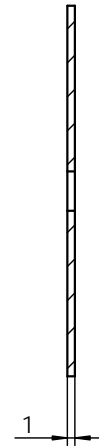
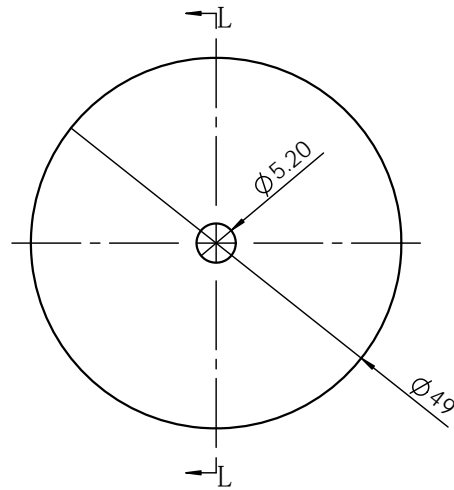

L-L
1:1

DIMENSIONS ARE IN mm TOLERANCES FRACTIONAL ± ANGULAR: MACH ± BEND ± ONE PLACE DECIMAL ± TWO PLACE DECIMAL ±		NAME	DATE	Richelieu Hardware		
	DRAWN					
	CHECKED			RICHELIEU /VENDOR ITEM NUMBER 246207020090		
	ENG APPR.					
	MFG APPR.					
	Q.A.			SIZE	DWG.NO.	REV.
MATERIAL: PVC	COMMENTS:		A		Washer	0
FINISH: PVC	1-2		DO NOT SCALE DRAWING		SHEET 1OF 1	
WEIGHT(GR): 2						

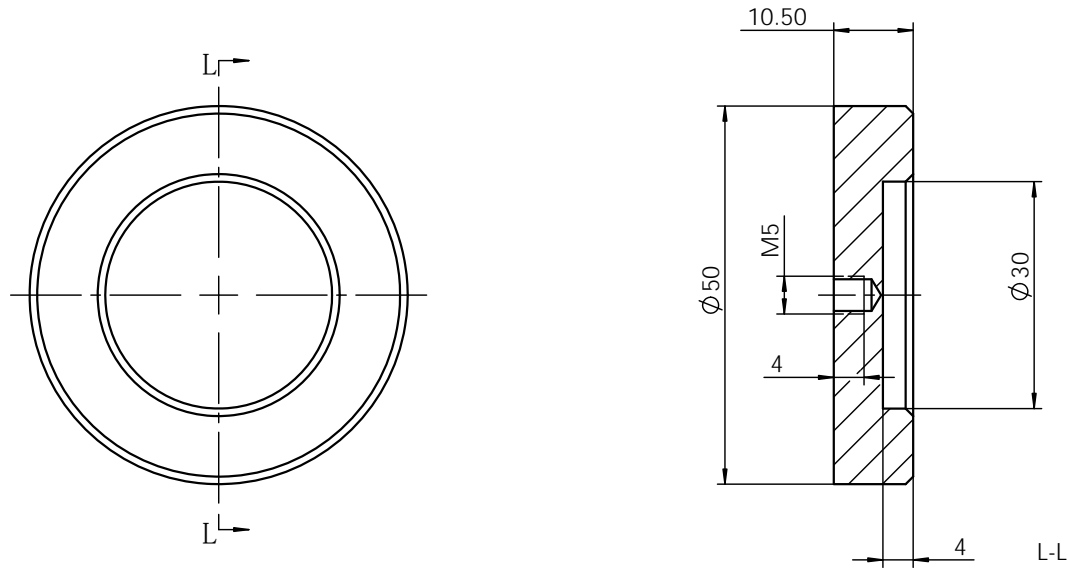

DIMENSIONS ARE IN mm TOLERANCES FRACTIONAL ± ANGULAR: MACH ± BEND ± ONE PLACE DECIMAL ± TWO PLACE DECIMAL ±		NAME	DATE	Richelieu Hardware		
	DRAWN					
	CHECKED			RICHELIEU /VENDOR ITEM NUMBER 246207020090		
	ENG APPR.					
	MFG APPR.					
	Q.A.			SIZE	DWG.NO.	REV.
MATERIAL: Steel	COMMENTS:			A	Knob	0
FINISH: Black	1-3			DO NOT SCALE DRAWING		SHEET 1OF 1
WEIGHT(GR): 141						

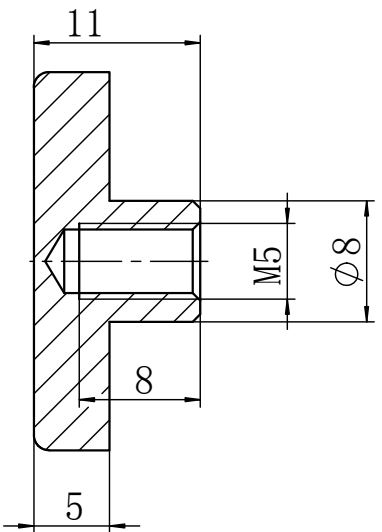
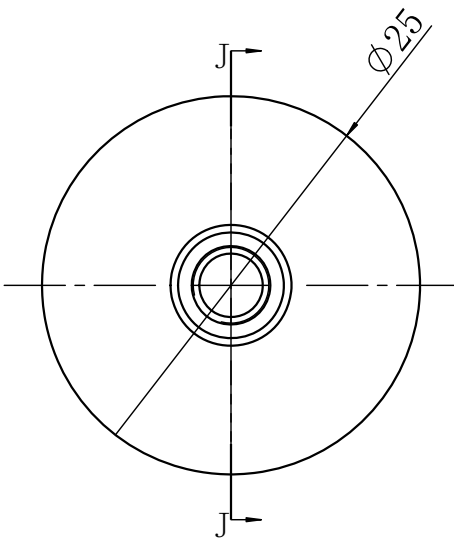
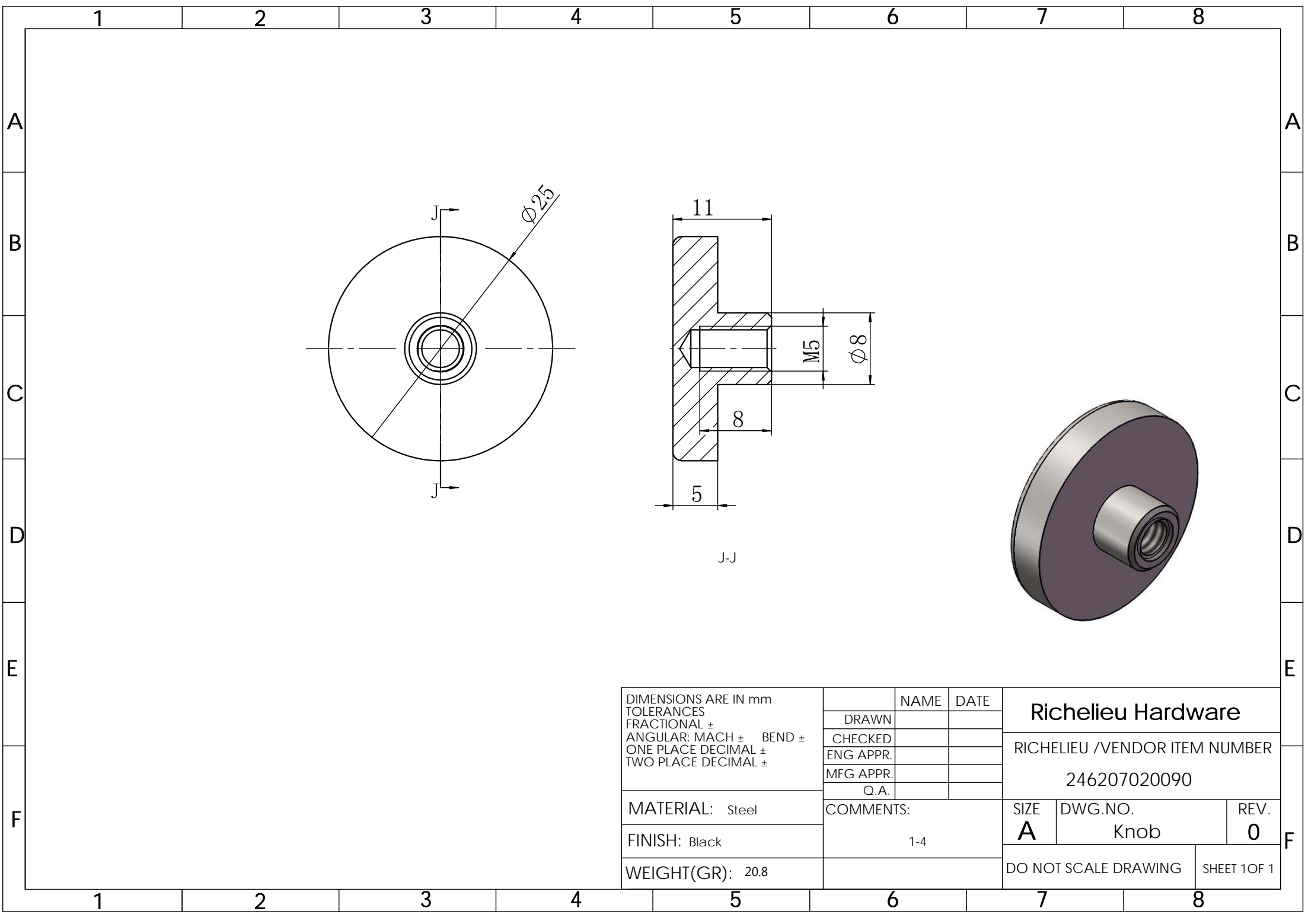

J-J

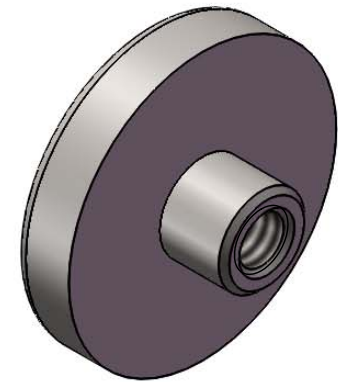

DIMENSIONS ARE IN mm TOLERANCES FRACTIONAL ± ANGULAR: MACH ± BEND ± ONE PLACE DECIMAL ± TWO PLACE DECIMAL ±		NAME	DATE	Richelieu Hardware		
	DRAWN					RICHELIEU /VENDOR ITEM NUMBER 246207020090
	CHECKED					
	ENG APPR.					
	MFG APPR.					
	Q.A.			SIZE	DWG.NO.	REV.
MATERIAL: Steel	COMMENTS: 1-4		A Knob		0	
FINISH: Black			DO NOT SCALE DRAWING		SHEET 1OF 1	
WEIGHT(GR): 20.8						

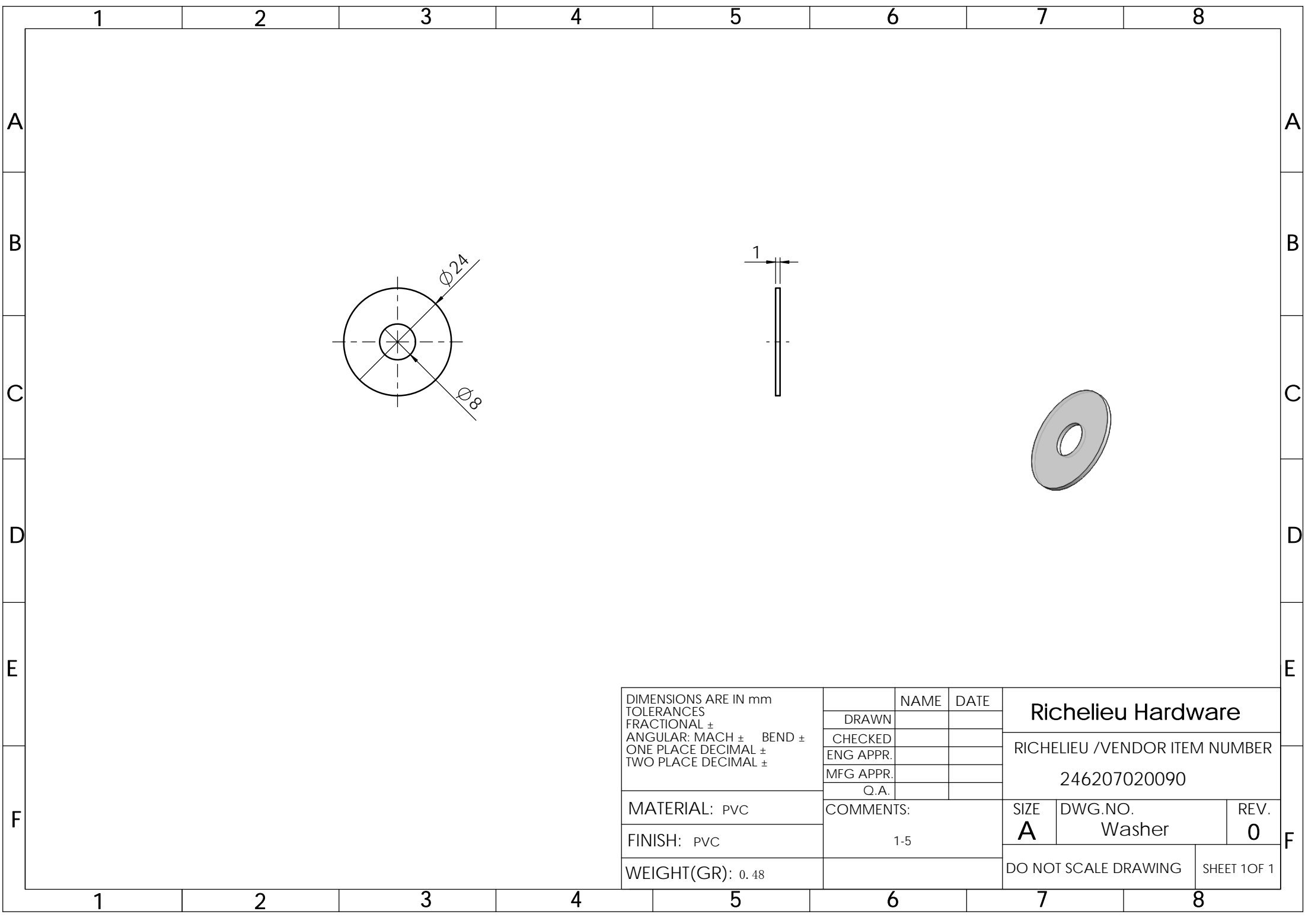

DIMENSIONS ARE IN mm TOLERANCES FRACTIONAL ± ANGULAR: MACH ± BEND ± ONE PLACE DECIMAL ± TWO PLACE DECIMAL ±		NAME	DATE	Richelieu Hardware		
	DRAWN					RICHELIEU /VENDOR ITEM NUMBER 246207020090
	CHECKED					
	ENG APPR.					
	MFG APPR.					
	Q.A.			SIZE	DWG.NO.	REV.
MATERIAL: PVC	COMMENTS:			A	Washer	0
FINISH: PVC	1-5			DO NOT SCALE DRAWING		SHEET 1OF 1
WEIGHT(GR): 0.48						

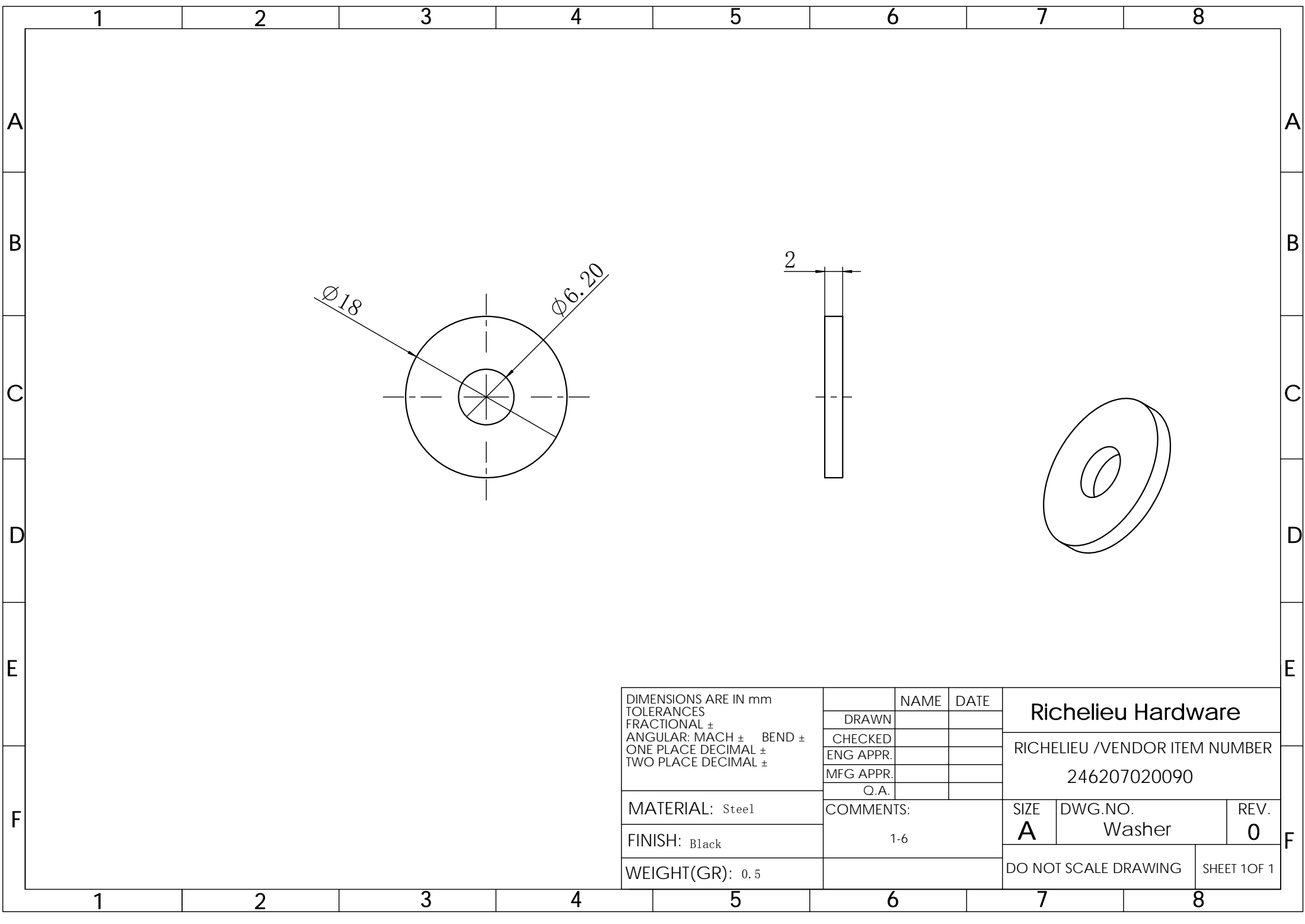

DIMENSIONS ARE IN mm TOLERANCES FRACTIONAL ± ANGULAR: MACH ± BEND ± ONE PLACE DECIMAL ± TWO PLACE DECIMAL ±		NAME	DATE	Richelieu Hardware		
	DRAWN					RICHELIEU /VENDOR ITEM NUMBER 246207020090
	CHECKED					
	ENG APPR.					
	MFG APPR.					
	Q.A.			SIZE	DWG.NO.	REV.
MATERIAL: Steel	COMMENTS:		A		Washer	0
FINISH: Black	1-6		DO NOT SCALE DRAWING		SHEET 1OF 1	
WEIGHT(GR): 0.5						

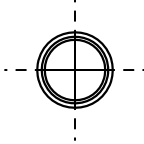
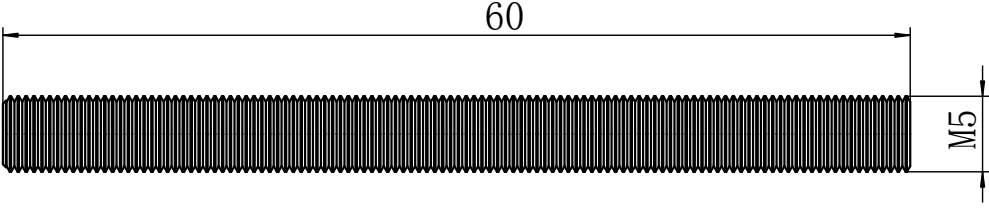
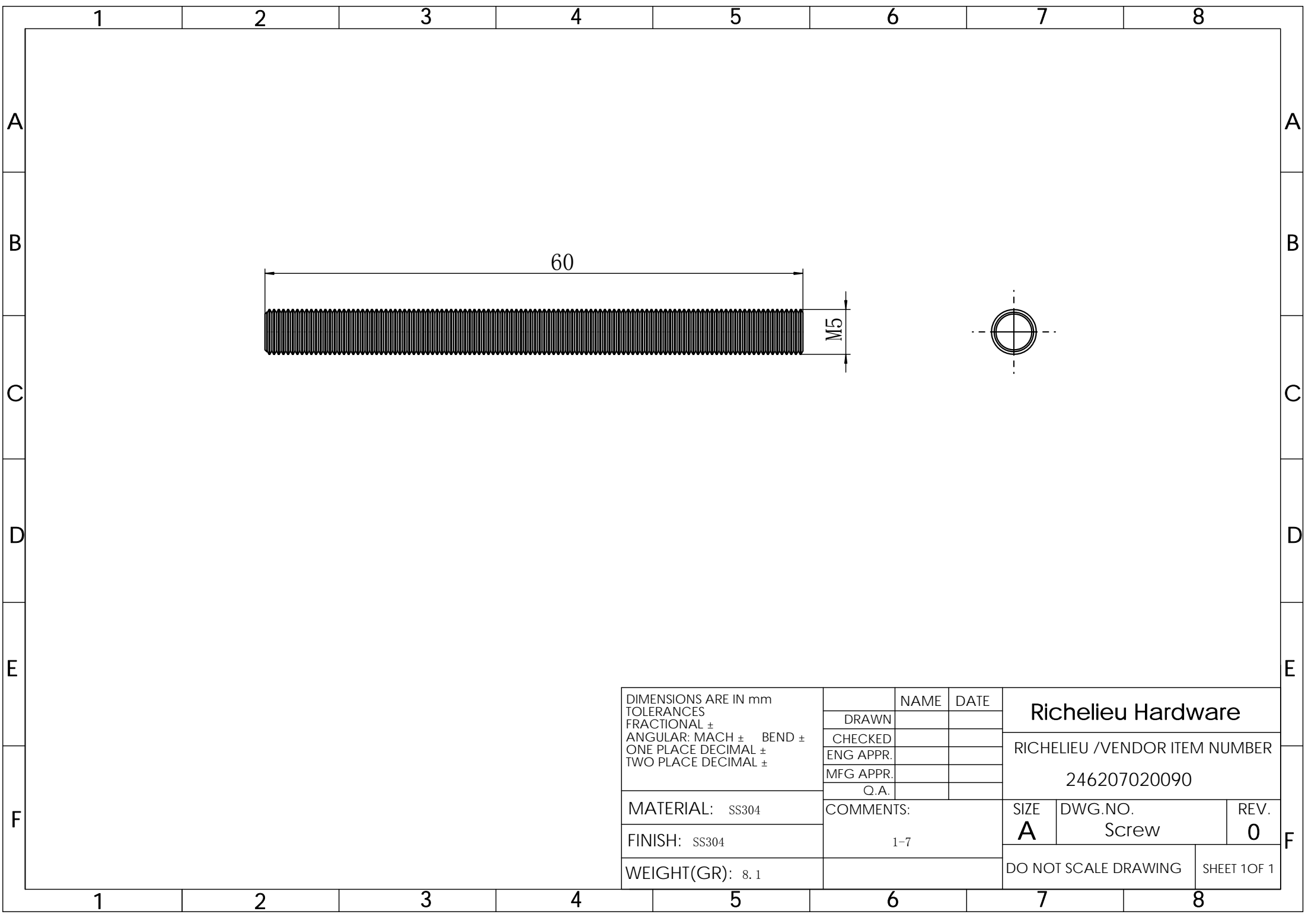

DIMENSIONS ARE IN mm TOLERANCES FRACTIONAL ± ANGULAR: MACH ± BEND ± ONE PLACE DECIMAL ± TWO PLACE DECIMAL ±		NAME	DATE	Richelieu Hardware		
	DRAWN					RICHELIEU /VENDOR ITEM NUMBER 246207020090
	CHECKED					
	ENG APPR.					
	MFG APPR.					
	Q.A.			SIZE	DWG.NO.	REV.
MATERIAL: SS304	COMMENTS: 1-7		A Screw		0	
FINISH: SS304			DO NOT SCALE DRAWING		SHEET 1OF 1	
WEIGHT(GR): 8.1						

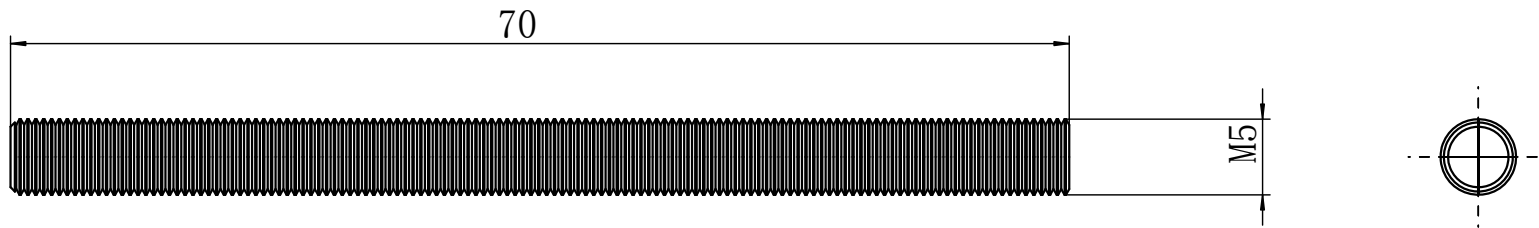

DIMENSIONS ARE IN mm TOLERANCES FRACTIONAL ± ANGULAR: MACH ± BEND ± ONE PLACE DECIMAL ± TWO PLACE DECIMAL ±		NAME	DATE	Richelieu Hardware		
	DRAWN					RICHELIEU /VENDOR ITEM NUMBER 246207020090
	CHECKED					
	ENG APPR.					
	MFG APPR.					
	Q.A.			SIZE	DWG.NO.	REV.
MATERIAL: SS304	COMMENTS: 2		A		Screw	0
FINISH: SS304			DO NOT SCALE DRAWING		SHEET 1OF 1	
WEIGHT(GR): 10						