

No	DRAWING No	QTY	DIMENSIONS ARE IN mm	Richelieu Hardware	
1			<b>TOLERANCES ±1mm</b> FRACTIONAL ± ANGULAR: MACH ± BEND ± ONE PLACE DECIMAL ± TWO PLACE DECIMAL ± MATERIAL: <b>Aluminum</b> FINISH: <b>Satin Aluminum</b> WEIGHT ( GR):	RICHELIEU ITEM NUMBER	
2				<b>1600SI21BC</b>	
3				SIZE	DWG. NO.
4				<b>A</b>	
5				DATE	REV.
6				<b>May.14th,2024</b>	
7					SHEET 1 OF 2
8					
9					

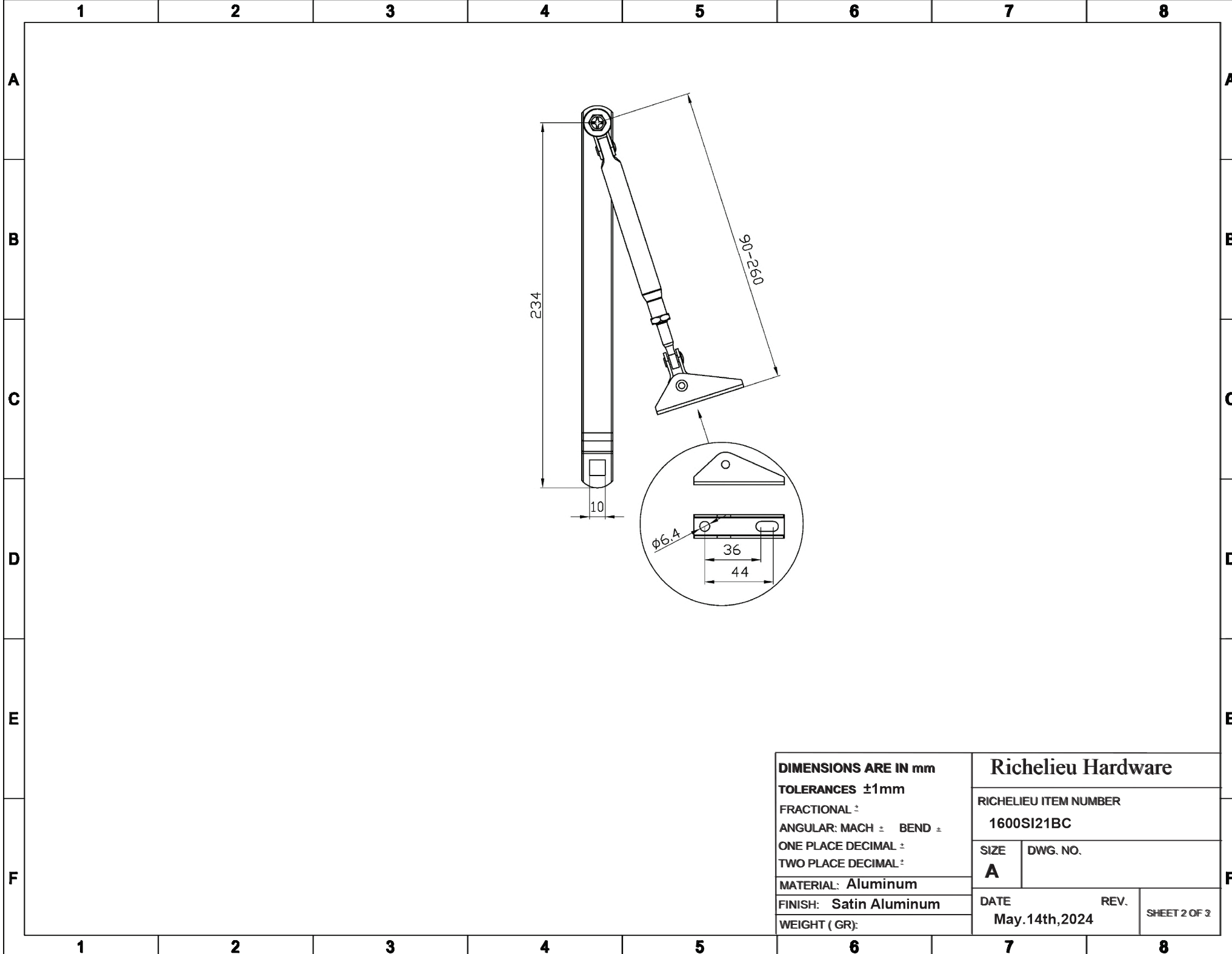

**DIMENSIONS ARE IN mm**  
**TOLERANCES ±1mm**  
 FRACTIONAL :  
 ANGULAR: MACH ± BEND ±  
 ONE PLACE DECIMAL ±  
 TWO PLACE DECIMAL ±  
**MATERIAL: Aluminum**  
**FINISH: Satin Aluminum**  
**WEIGHT ( GR):**

<b>Richelieu Hardware</b>		
RICHELIEU ITEM NUMBER <b>1600SI21BC</b>		
SIZE <b>A</b>	DWG. NO.	
DATE May.14th,2024	REV.	SHEET 2 OF 3