

V-0930 Releasable Instructions

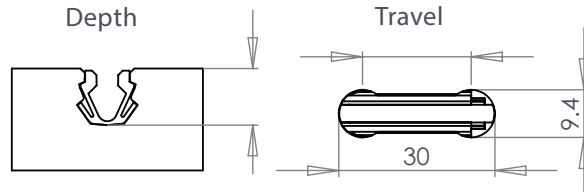

1. Milling

- (i) Plunge
- (ii) Travel
- (iii) Out

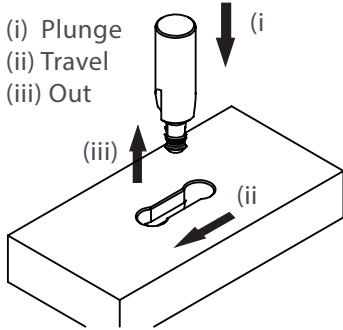

Recommended Spacing

- (a): 35mm to 80mm
- (b): 100mm to 250mm

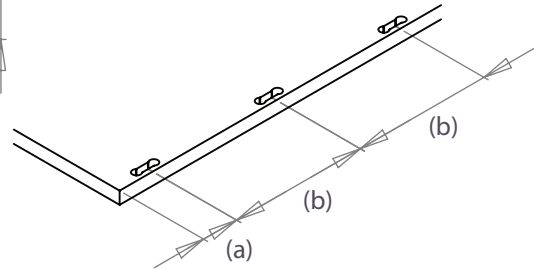

Recommended Settings

Depth: 9.5mm, +/- 0.5mm
 Travel Centre to Centre: 20.6mm
 Rotation Speed: CNC speeds vary with different materials. Maximum cutter rotation: 18,000

2. Housing

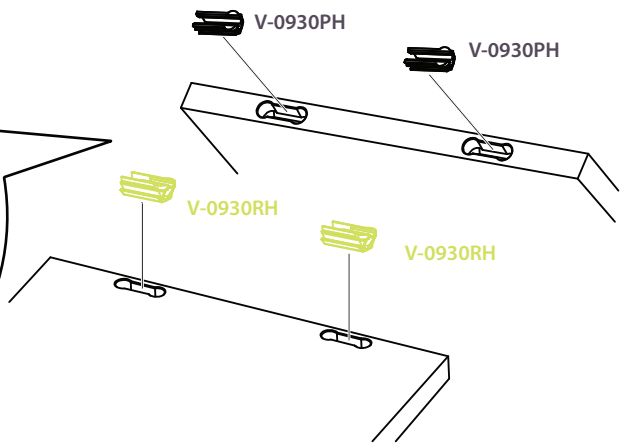
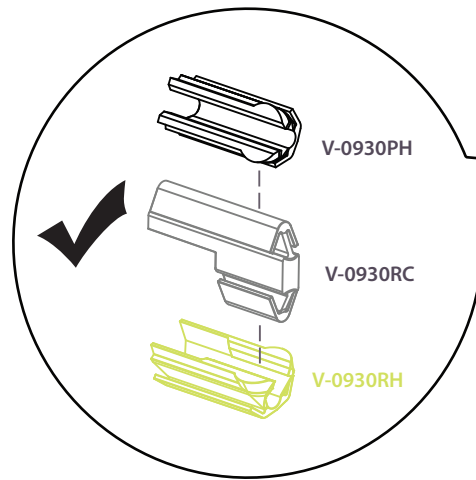

3. Assembly - Simply push or slide to connect

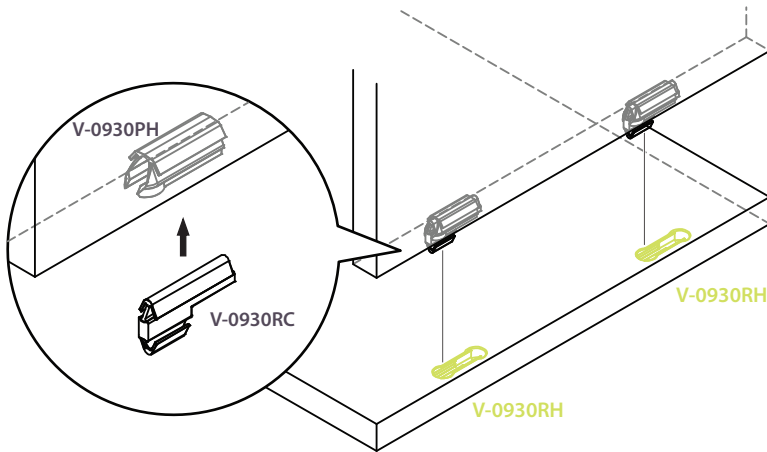

4. Release

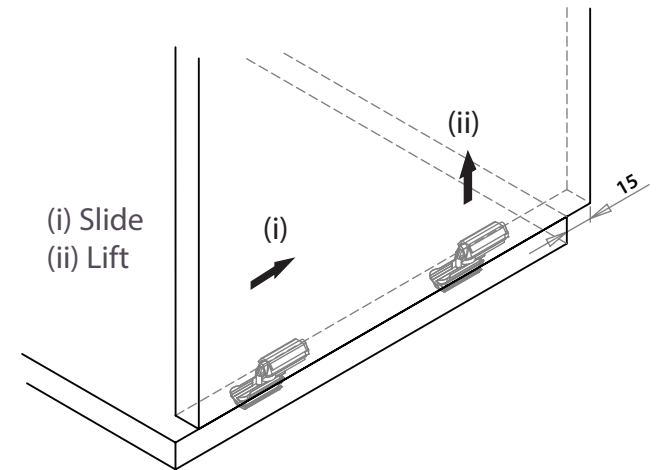

How it works

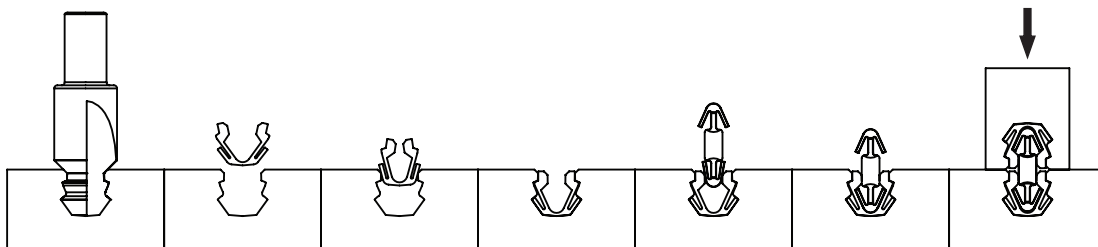

Simply push or slide to connect

