

V-0930 Permanent Instructions

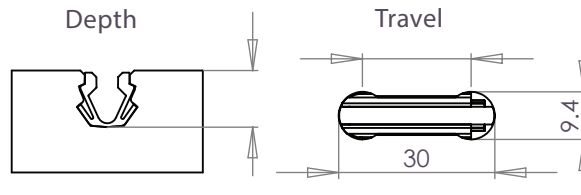

1. Milling

- (i) Plunge
- (ii) Travel
- (iii) Out

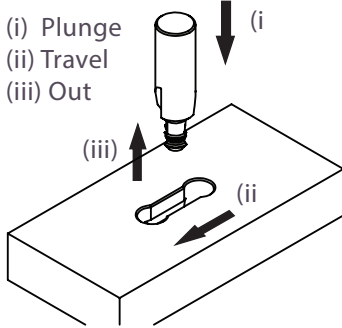

Recommended Spacing

- (a): 35mm to 80mm
- (b): 150mm to 350mm

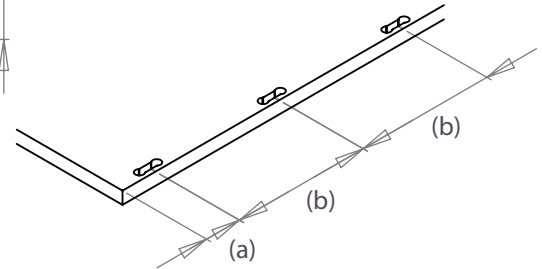

Recommended Settings

Depth: 9.5mm, +/- 0.5mm
Travel Centre to Centre: 20.6mm
Rotation Speed: CNC speeds vary with different materials. Maximum cutter rotation: 18,000

2. Housing

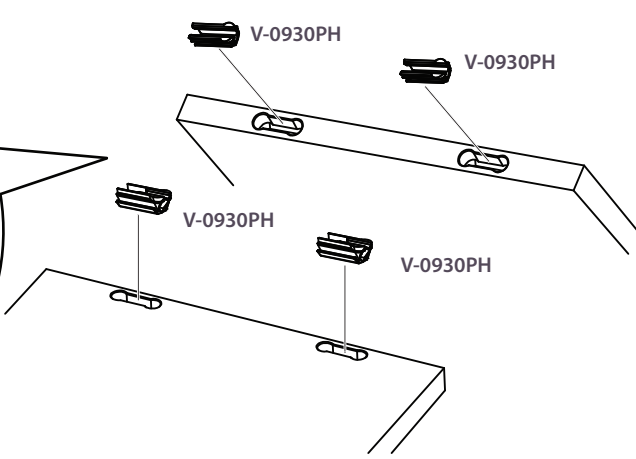
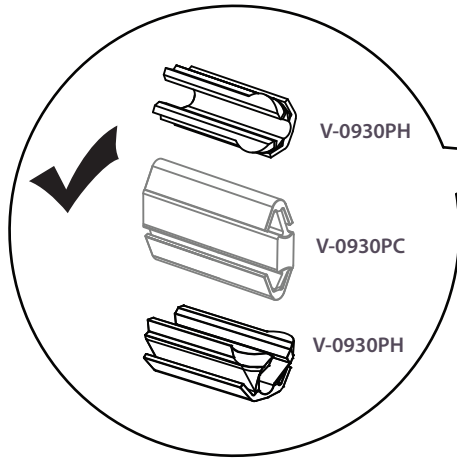

3. Assembly - Simply push into place to connect

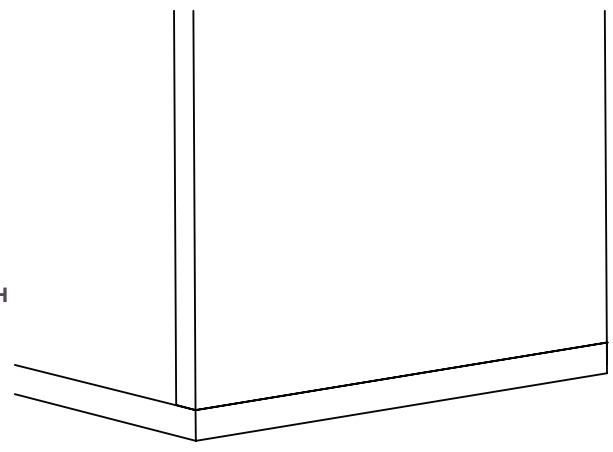
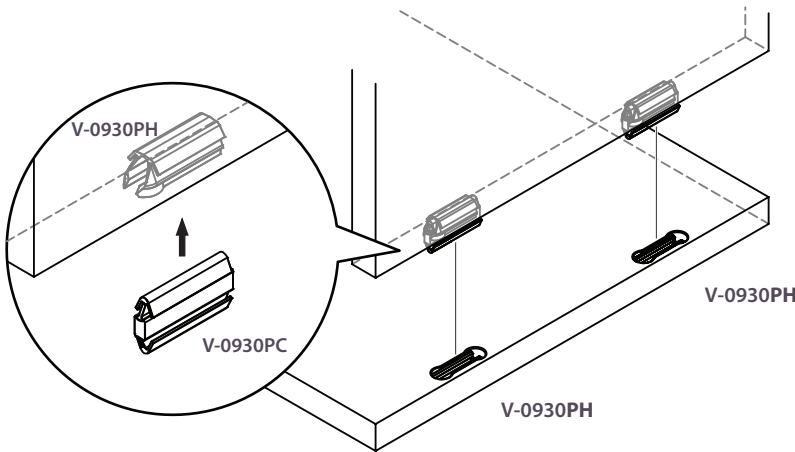

How it works

