

2024.02.08	Ajouté 45XP2G650, 45XP2G700
DATE	DESCRIPTION
	REVISION

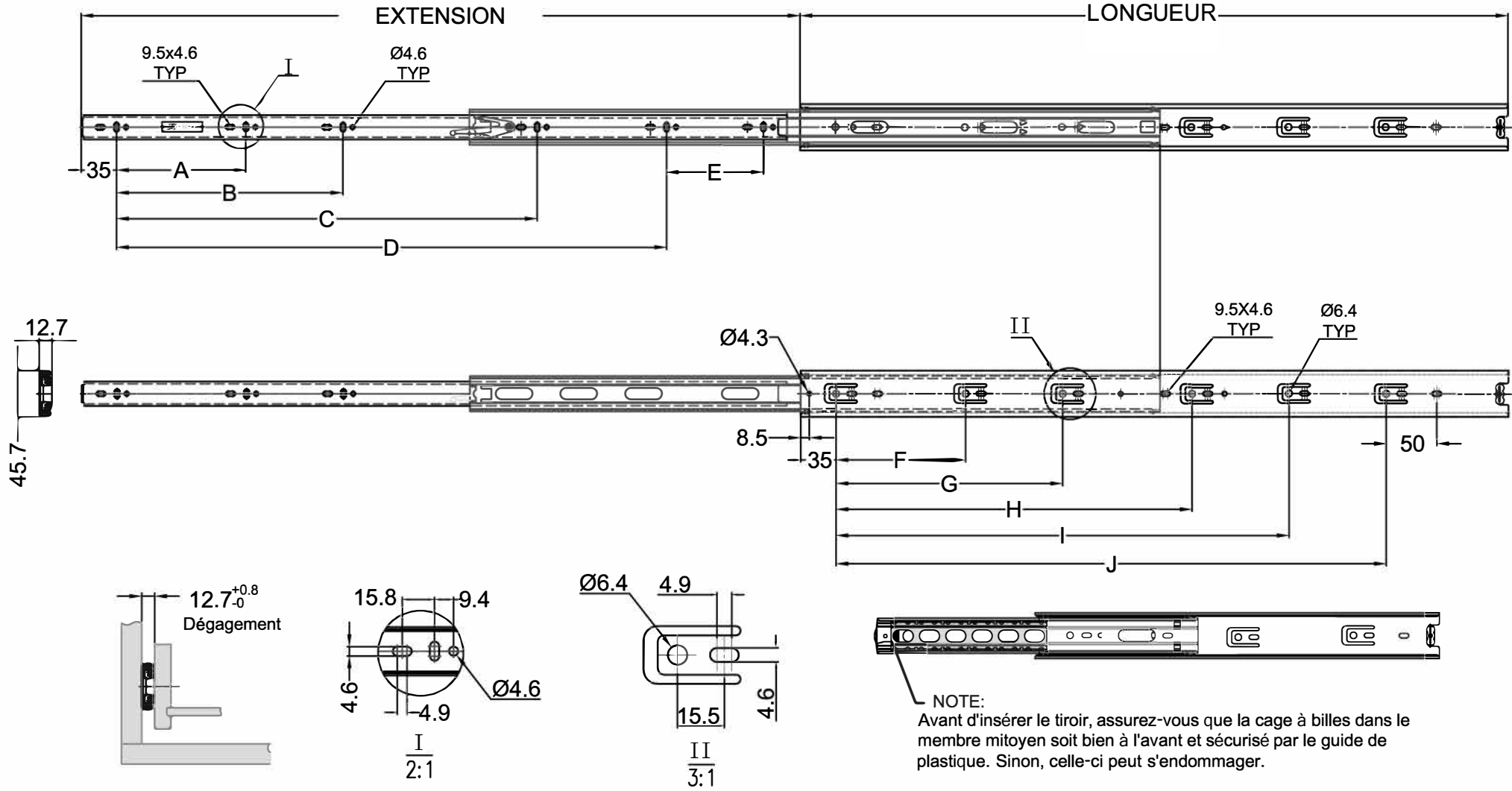

ITEM#	LONGUEUR	EXTENSION	A	B	C	D	E	F	G	H	I	J
45XP2G250	250	254	64				125.8	64	160			
45XP2G300	300	306	96				143.8	128	224			
45XP2G350	350	356	96				193.8	128	224			
45XP2G400	400	406	128				211.8	128	224	320		
45XP2G450	450	457	128	320			69.8	128	224	352		
45XP2G500	500	508	128	320			119.8	128	224	352	416	
45XP2G550	550	559	128	320			169.8	128	224	352	448	
45XP2G600	600	610	128	224	416		123.8	128	224	352	480	
45XP2G650	650	660	128	224	416	544	45.8	128	224	352	544	
45XP2G700	700	711	128	224	416	544	95.8	128	224	352	448	544

TOLÉRANCE NON SPÉCIFIÉ			QUINCAILLERIE RICHELIEU			
DIMENSION	LINEAIRE	ANGLE				
X.0			INSTRUCTION_XPERT PLEIN.			
X.00			STAND. #45XP2G			
Matériel		CONCEPTION	DATE	2024.02.08	Unit:	Échelle
Finis		APPROUVÉ	DATE		mm	