

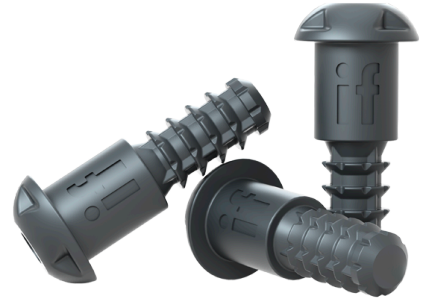

Key Features

- A self-clamping, invisible connector
- Creates an incredibly strong joint
- Ideal for boring and insertion machines
- Quick and simple assembly of cabinets
- Can be reassembled many times
- Made from glass fibre reinforced nylon

Invisible Connector



Machining

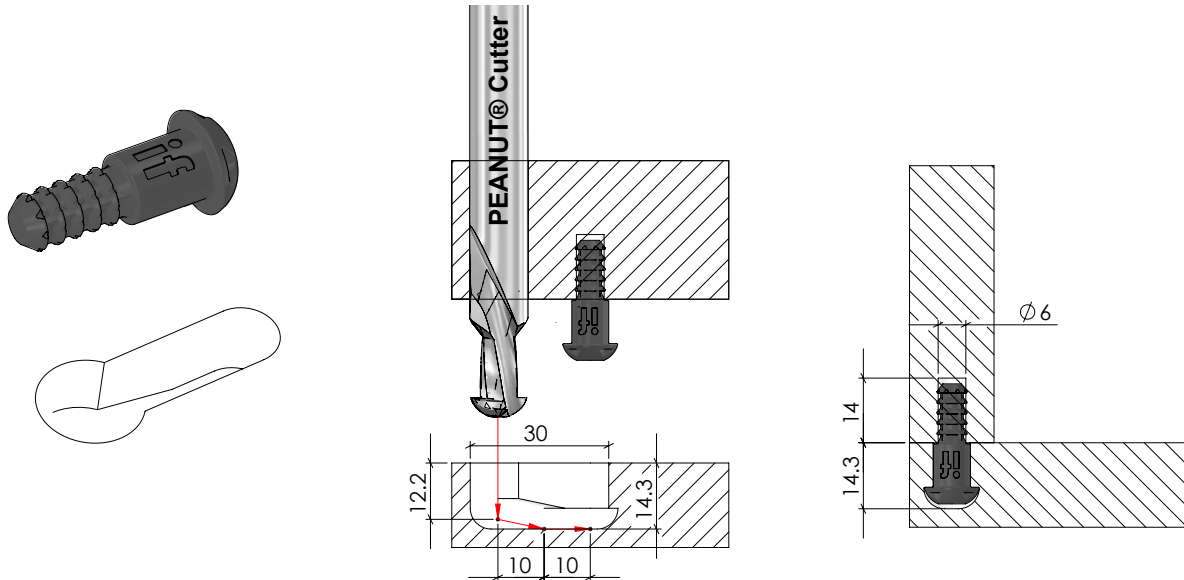

Assembly

Example 1
45° Joint

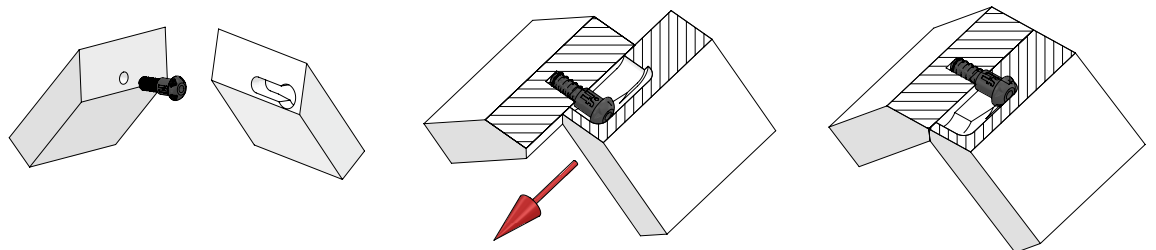

Example 2
Face-to-face

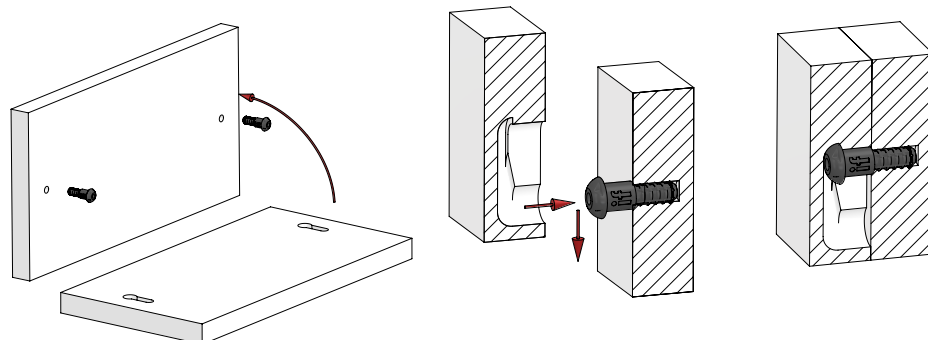



Applications

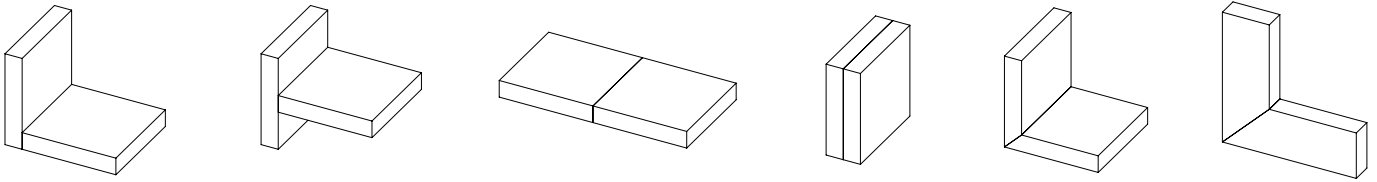

Technical Specifications

PEANUT® 3 Technical data

COMPONENT COMPOSITION	GLASS-FIBRE REINFORCED PLAST
MATERIAL THICKNESS	90°: >15.3MM / 45°: >18mm
TOLERANCE (PEANUT® CUTTER SLOT)	+0.3mm and -0.4mm (DEPTH)

Strength Data

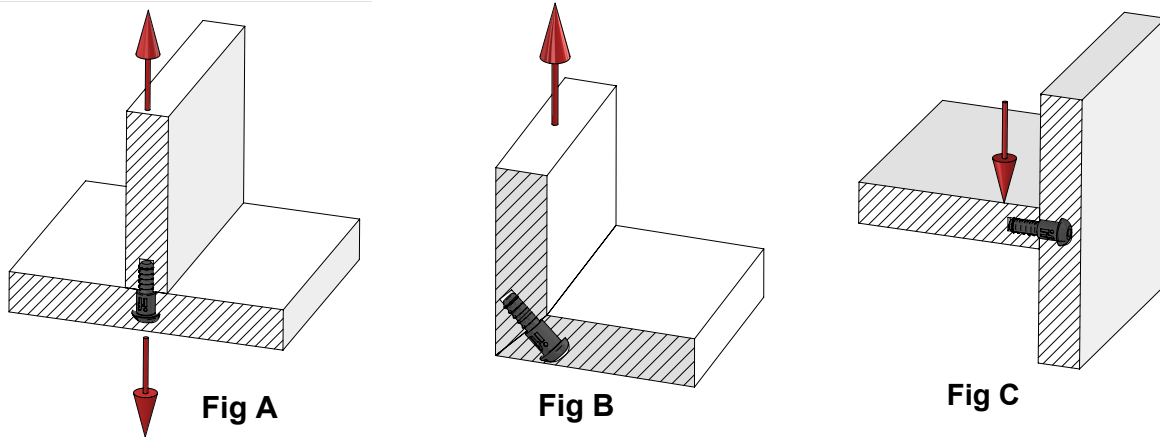

JOINT TYPE: 90° JOINT

PEANUT® 3 Tensile strength (based on 1 component):

TESTED BY:



MATERIAL	TENSILE STRENGTH (Fig. A)
PARTICLE BOARD (18mm MFC) from EGGER	900 N / 90 KG (1 COMPONENT)
MDF (18mm)	1050 N / 105 KG (1 COMPONENT)

PLEASE NOTE THAT THE STRENGTH MAY VARY DEPENDING ON MATERIAL AND QUALITY OF MATERIAL USED.

JOINT TYPE: 45° MITRE JOINT

PEANUT® 3 Tensile strength (based on 1 component):

TESTED BY:



MATERIAL	TENSILE STRENGTH (Fig. B)
PARTICLE BOARD (18mm MFC) from EGGER	600 N / 60 KG (1 COMPONENT)
MDF (18mm)	670 N / 67KG (1 COMPONENT)

PLEASE NOTE THAT THE STRENGTH MAY VARY DEPENDING ON MATERIAL AND QUALITY OF MATERIAL USED.

JOINT TYPE: 90° JOINT

PEANUT® 3 Shear strength (based on 1 component):

TESTED BY:



MATERIAL	SHEAR STRENGTH (Fig. C)
PARTICLE BOARD (18mm MFC) from EGGER	650 N / 65 KG (1 COMPONENT)
MDF (18mm)	920 N / 92 KG (1 COMPONENT)

PLEASE NOTE THAT THE STRENGTH MAY VARY DEPENDING ON MATERIAL AND QUALITY OF MATERIAL USED.