

# INSTRUCTIONS

## RD12 + V-1230RH

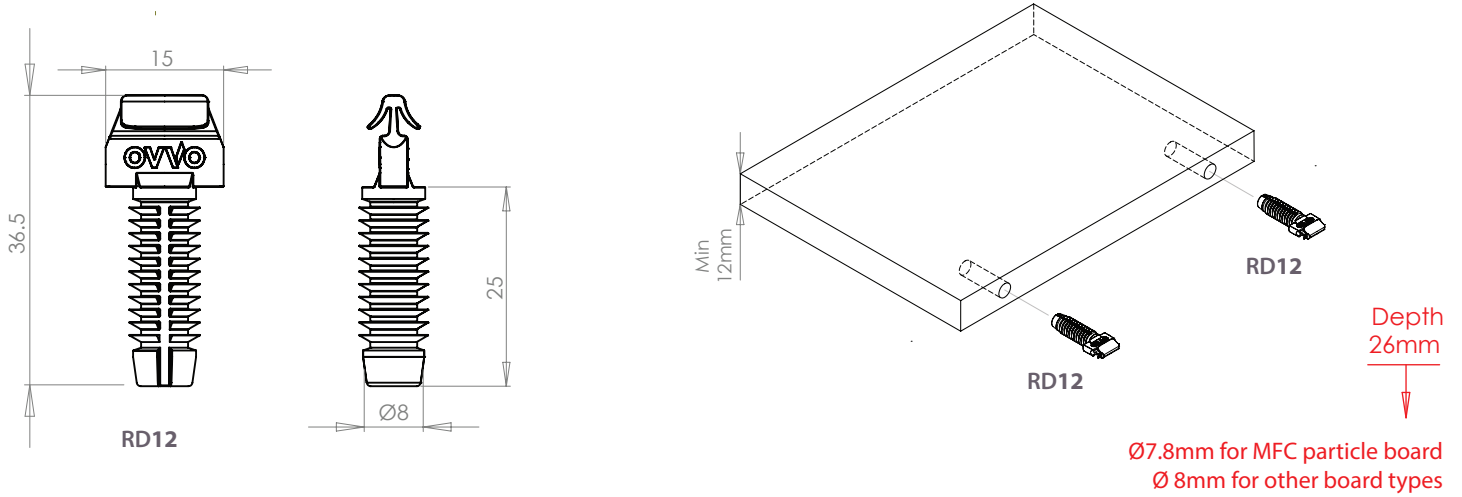

### 1. Drilling for RD12



### 2. Milling for V-1230RH

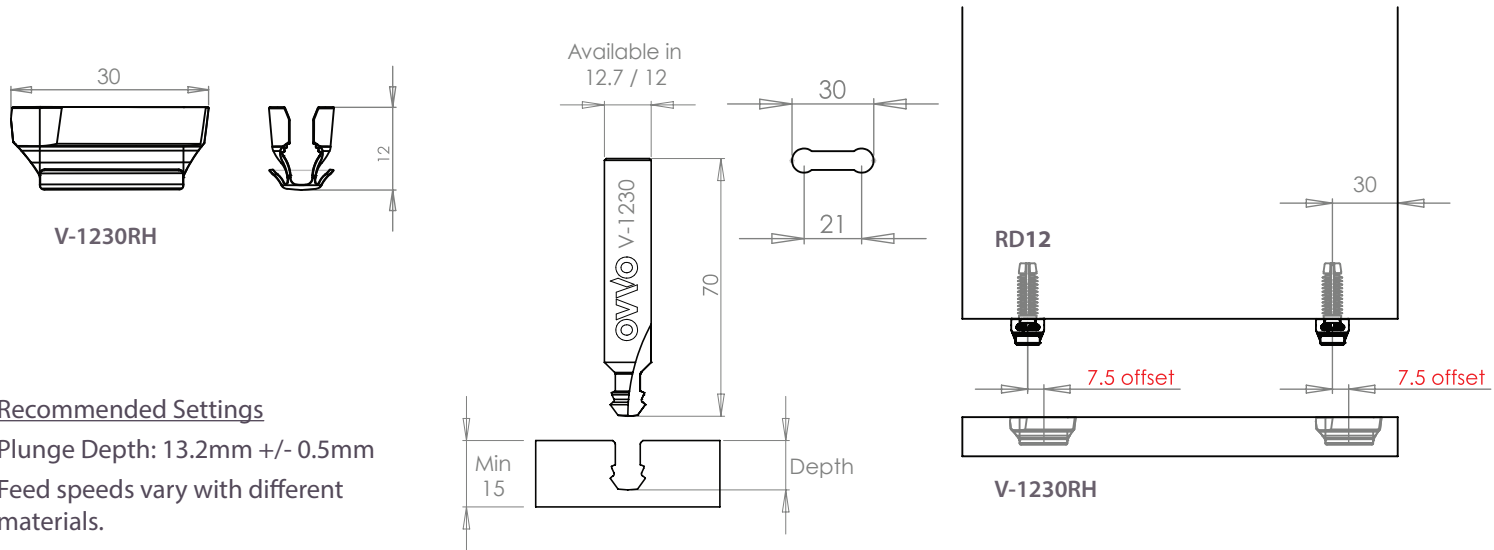

#### Recommended Settings

Plunge Depth: 13.2mm +/- 0.5mm  
Feed speeds vary with different materials.

### 3. Assembly

