

123020P1000H

Includes: V-1230PD-20 + V-1230PH

Instructions

1. Drilling for V-1230PD

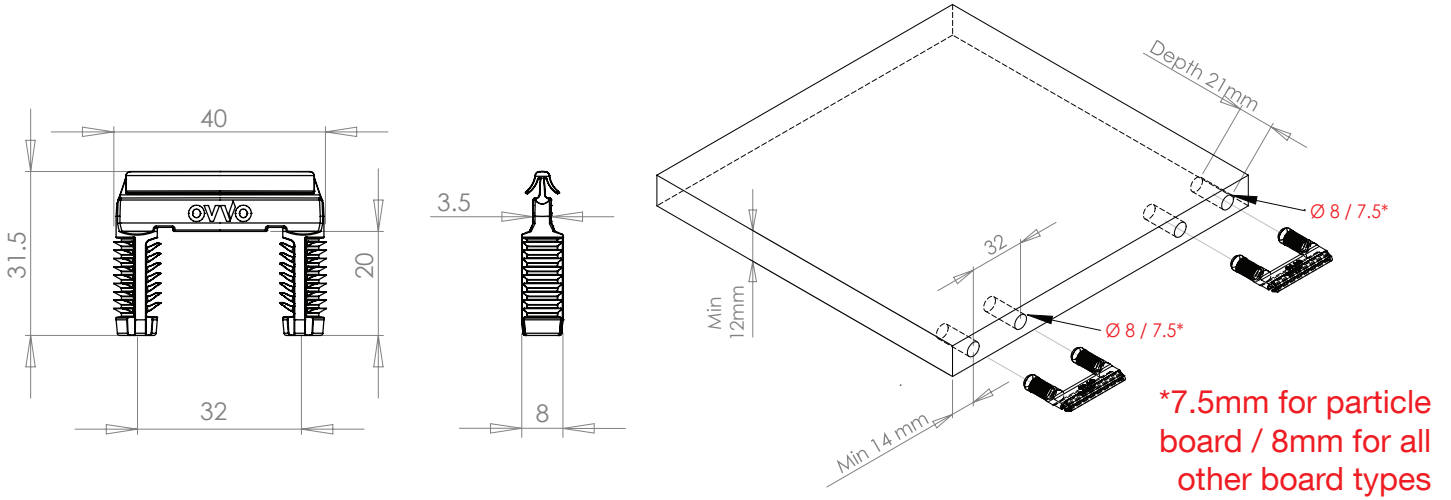

2. Milling for V-1230PH

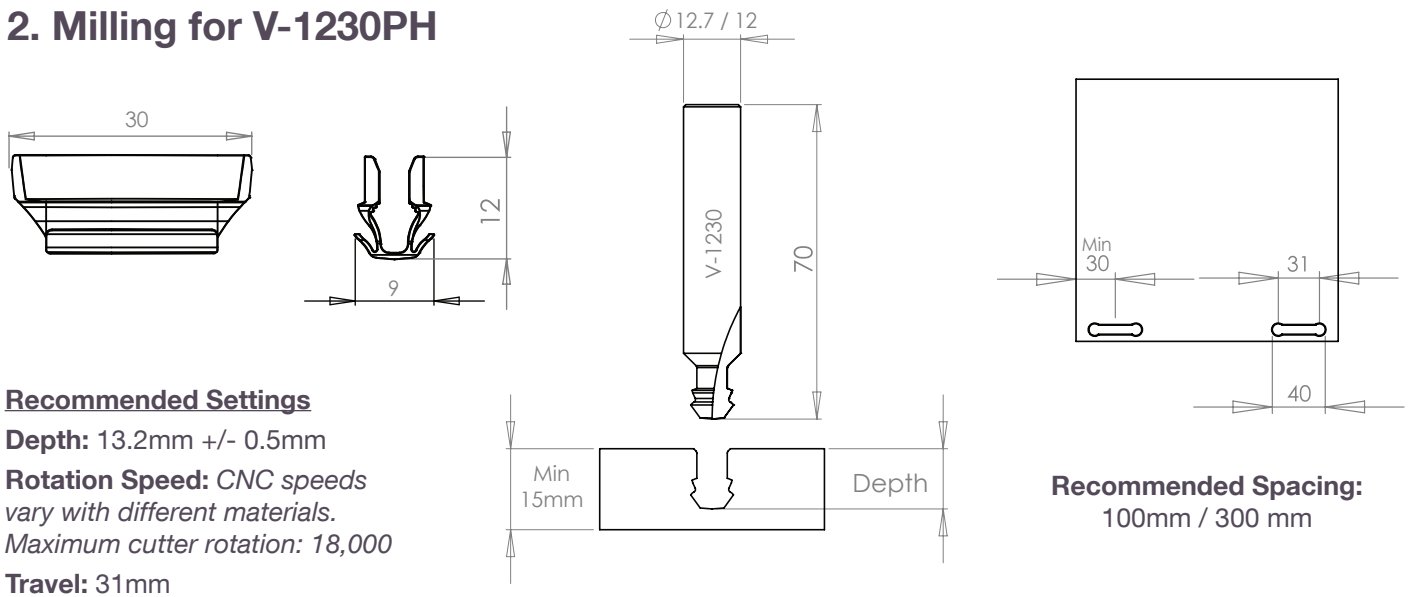

Recommended Settings

Depth: 13.2mm +/- 0.5mm

Rotation Speed: CNC speeds vary with different materials.

Maximum cutter rotation: 18,000

Travel: 31mm

3. Assembly

