

123010P100H

Includes: V-1230PD-10 + V1230PH

Instructions

1. Drilling for V-1230PD-10

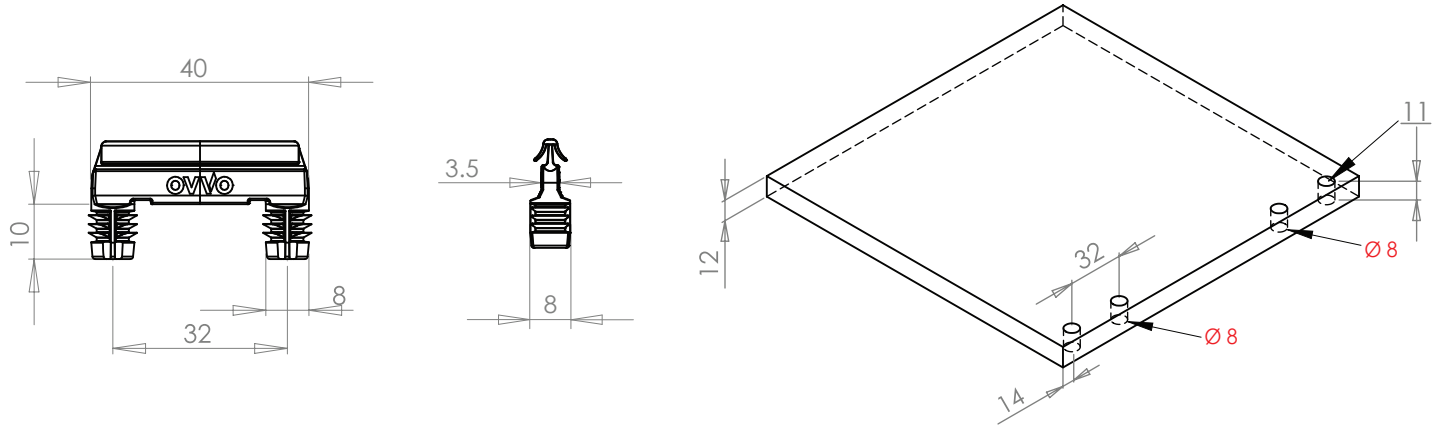

2. Milling for V-1230PH

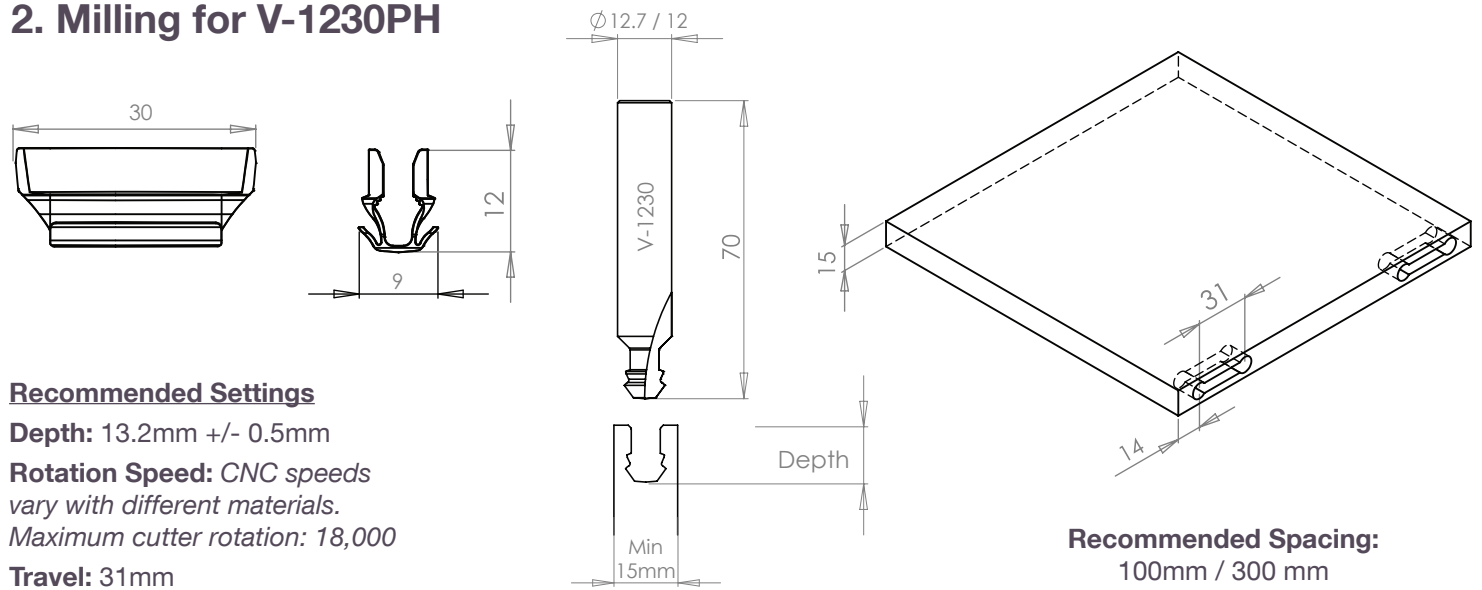

Recommended Settings
Depth: 13.2mm +/- 0.5mm
Rotation Speed: CNC speeds vary with different materials.
 Maximum cutter rotation: 18,000
Travel: 31mm

3. Assembly

