

V-1230 Releasable Instructions

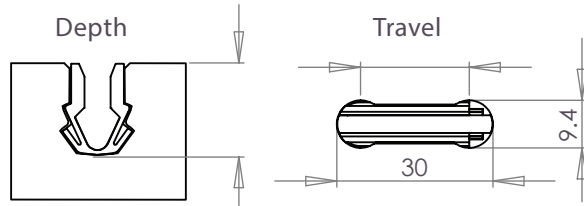

1. Milling

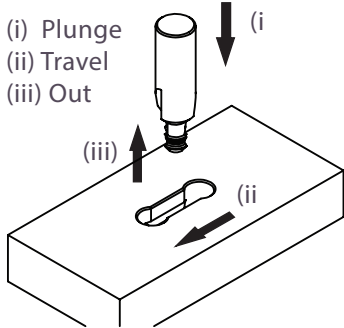

Recommended Spacing

- (a): 35mm to 80mm
- (b): 100mm to 250mm

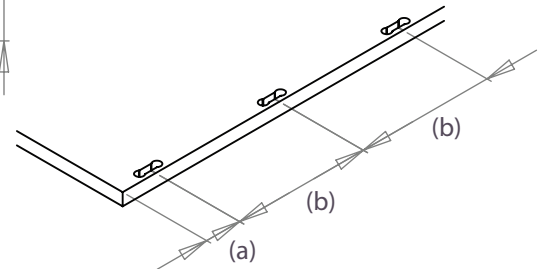

Recommended Settings

Depth: 12.5mm, +/- 0.5mm
 Travel Centre to Centre: 20.5mm (min) - 20.7mm
 Rotation Speed: CNC speeds vary with different materials. Maximum cutter rotation: 18,000

2. Housing

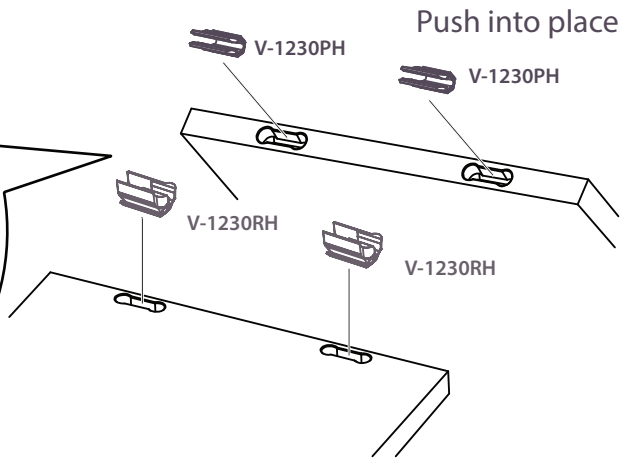
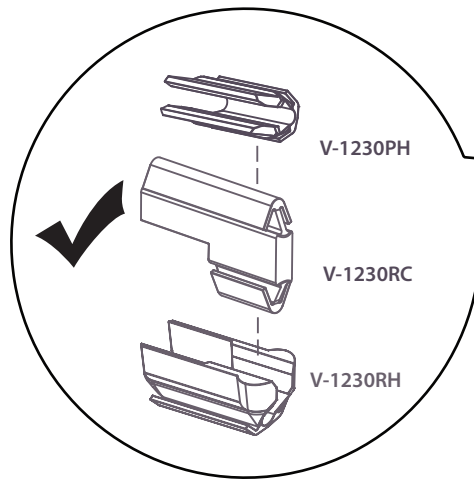
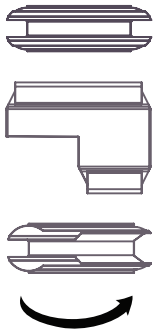

3. Assembly - Simply slide to connect

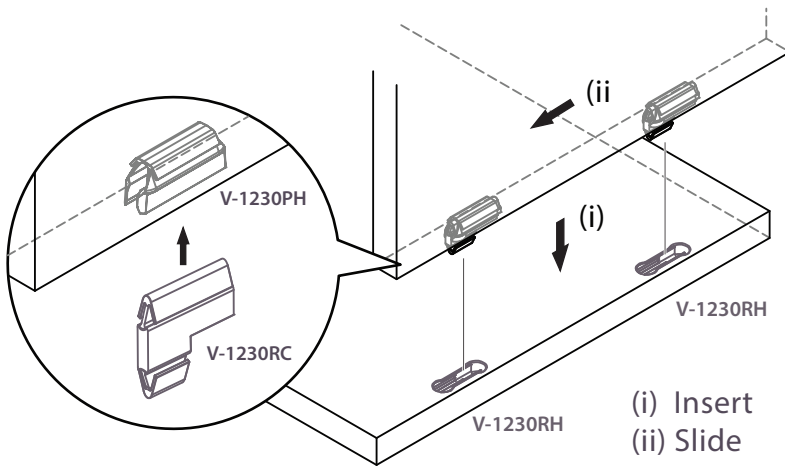

4. Release

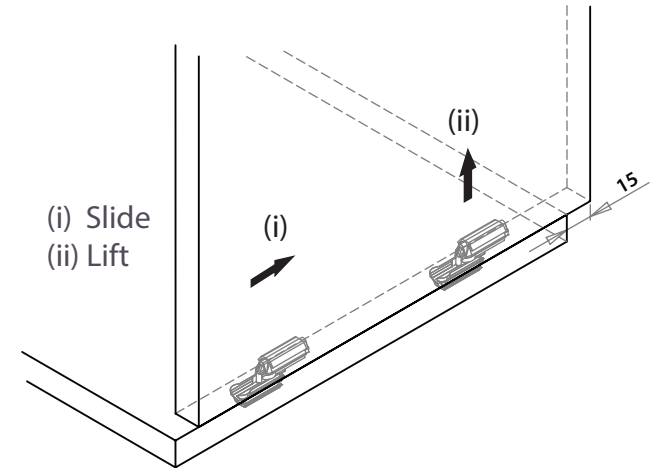

How it works

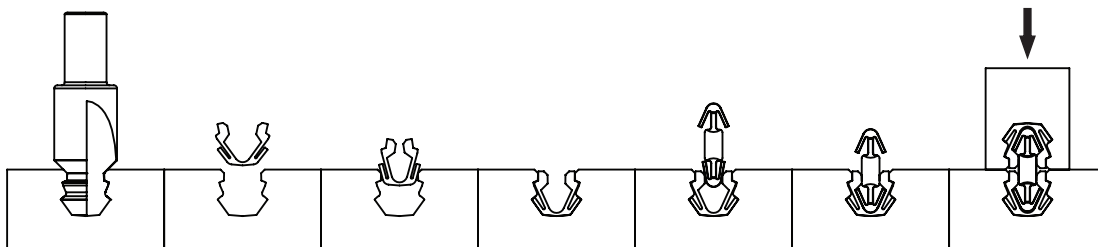

Simply slide to connect

