

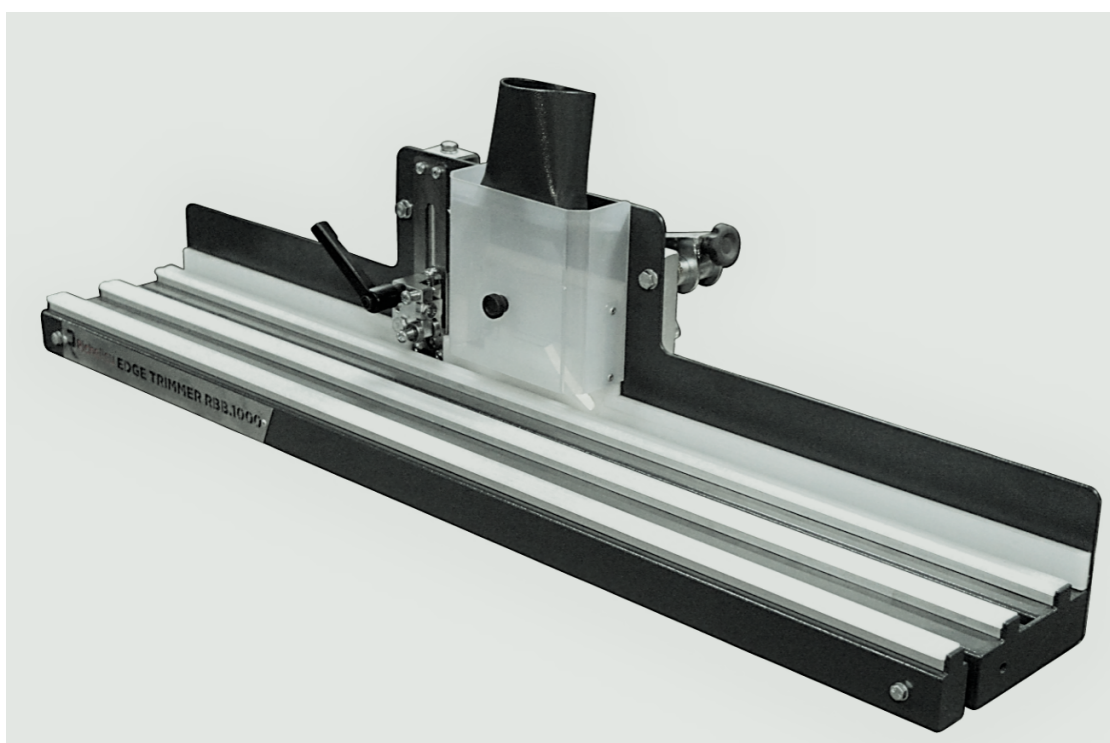

RBB.1000

EDGE TRIMMER MACHINE

INSTRUCTION MANUAL



ATTENTION: READ THIS MANUAL BEFORE USING YOUR MACHINE.

INSTRUCTION MANUAL

Important information you should know:

- The images in this manual are illustrative and are meant to demonstrate the correct operation of your product, there may be small changes in relation to the images.



ALWAYS USE PROPER PROTECTIVE EQUIPMENTS TO OPERATE THIS MACHINE.

Important Safety Instructions



WARNING: When working with machines, always follow the safety precautions to reduce the risk of fire, electric shock and injury, including the following:

READ ALL INSTRUCTIONS



CAUTION: WHEN DOING MAINTENANCE, REPLACE ONLY WITH IDENTICAL PARTS.

Repair or replace damaged wiring.

SAFETY INSTRUCTIONS FOR ALL EQUIPMENTS

- **Keep a clean work surface.** Cluttered areas and work surfaces are invite accidents.
- **Do not use the Edge Trimmer in hazardous environments.** Do not use machine in damp or wet locations or exposed to rain. Keep well clean work area.
- **Keep children away.** Visitors should be kept at a safe distance from work area.
- **Do not force tool.** It will perform the job better and safer for the intended use.
- **Use appropriate equipment.** Do not wear loose clothing, gloves, chains, rings, bracelets or other accessories that could get caught in moving parts.
- **It is recommended** wearing shoes with non-slip soles. Use protection for the hair in order to hold them.
- **Always wear safety glasses.** Also use hearing protection.
- **Do not overreach on the equipment.** Maintain balance and feet in comfortable position at all times.

- **Keep all tools in order.** Keep tools sharp and clean for better and safer performance. Follow the instructions for lubricating and changing accessories.
- **Unplug the machine** before servicing or changing accessories such as scissors, cutters etc.
- **Reduce the risk of unintentional starting.** Ensure that the switch is in the "OFF" position (off) before connecting the wire to the plug.
- **Use recommended accessories.** See the instruction manual to check recommended accessories. Improper use of accessories may cause risk of injury to persons.
- **Never step on the machine.** May occur serious accident if the machine is dented or if parts are accidentally touched.
- **Check for damaged parts.** Before continuing the use of Edge Trimmer, a guard or other part that is damaged should be examined carefully to determine its proper operation and perform its function properly. Check the alignment of moving parts, breakage of parts, mounting and any other condition that may affect its operation. Any part that is damaged should be repaired or replaced immediately. Do not use the tool if the switch does not turn on or off.
- **Never leave a running tool unattended.** Turn off the ignition key.
- **The engine of this machine can emit sparks,** and explode flammable gases.
- **Extension cables.** Make sure your extension cord is in good condition. When using an extension, be sure of their ability to transmit the electrical current used by your product. An undersized cord will cause drop in voltage resulting in loss of power and overheating. The following table shows the correct size to be used depending on the cable diameter and amperage rate. If in doubt, use a cable with a higher level of capacity. **IMPORTANT:** Do not use an extension cord with length above 20 meters

Cable 2 wires		Cable 3 wires	
Ø (mm ²)	Amperage	Ø (mm ²)	Amperage
0,5	9	0,5	8
1,0	13	1,0	12
1,5	16,5	1,5	15
2,5	23	2,5	20

Additional safety rules for Edge Trimmer:



CAUTION: FAILURE TO ATTEND THESE WARNINGS MAY RESULT IN PERSONAL INJURY AND SERIOUS DAMAGE TO THE MACHINE.

- **Protect** the electric power supply line with at least a 20 amp fuse or a circuit breaker switch.
- **Make sure** the advance is turning in the right direction.
- **Make sure** that the knobs and screws are properly tightened and safe before starting any operation.
- **Keep** sharp tools.
- **Keep** vents free of chips or dirty engines.
- **Keep** hands away from moving or sharp parts.
- **Turn off the machine** and unplug the power cord before maintenance or adjustments of the tool.
- **Support** long pieces with a clamping device for wood.
- **Do not attempt** to operate the machine in another voltage beyond designated.
- **Do not use** larger or smaller tools than recommended.
- **Do not apply** lubricant to the tools during use.
- **Do not operate** without some parts of the machine.
- **Do not put your hands** less than 4in from the shaft.
- **Do not put your hands** in closed parts of the machine unless it is turned off and unplugged.
- **Do not use** lubricants or cleaners (particularly sprays and aerosols) in the vicinity of the plastic guard. The polycarbonate material used in the guard is sensitive to certain chemicals.

WARNING: Some dust created by the act of sanding, cutting, grinding, drilling and other construction-related activities contains chemicals that can cause cancer, birth defects or other reproductive harm. Some examples of these products are: Lead-based paint; crystal silica bricks, concrete and other masonry products; and arsenic and chromium from chemically treated wood.



CAUTION: Do not connect the unit to the power outlet until all instructions have been read and understood. Always tighten the adjustment tabs before using the machine. Think: "I can prevent accidents".

Do not operate the machine unless the guards are in their proper places. Always use protective ears and goggles.

Electrical connection

To avoid burning risk, check the voltage of your outlet before starting the machine. If necessary make the change of your power with the help of a specialist.

Ensure that your power supply is in accordance with the designated on the board. A 10% decrease in voltage or more will cause loss of power and overheating. All equipment MAKSIWA are tested at the factory. If this machine does not work, check the electricity supply.

Check the compatibility of your outlet and plug the machine. Do not do patches and adaptations. To avoid electrical shock and damage to the equipment always ground the machine.

Familiarization

Put the machine on a smooth and flat surface. Check the pictures and watch the descriptions to familiarize yourself with its components. The next section will deal with the necessary adjustments for the proper functioning of the machine. You should know these parts and will need to know where they are.

Especifications

Power	550 W
Tape Thickness	Until 1,0 mm
Max. Height of Workpiece	60 mm (2 3/8")
Table Length	1.000 mm (39")
Adjust of Table Width	155 to 410 mm (6" to 16")
Speed	32.000 RPM
Tools Collets	6mm and 1/4"
Net Weight	19 Kg (41,9 pounds)

Installation

For packaging purposes, the machine is not fully assembled.

If you notice any damage caused by transportation, while you open the package, notify your supplier immediately. Do not operate the machine.



Dispose the packaging in a friendly way with the environment.

The Edge Trimmer is designed to operate indoors and should be placed on a firm, stable and level surface.

CAUTION: To prevent the machine from moving and causing lack of precision, ensure that the base where it is supported is not uneven.

UNPACKING AND ASSEMBLY

UNPACKING

Due to modern mass production techniques, it is unlikely that Edge Trimmer RBB.1000 MAKSIWA is faulty or have parts missing. If you find anything wrong, do not use the machine until the parts are replaced or the fault is corrected. Doing this you are avoiding serious injury.

1. You will receive your machine packed.
2. Remove the machine from the packed with all the parts and accessories that go with it. For ease assembly, place it on a bench. Note the pieces that came with your equipment:

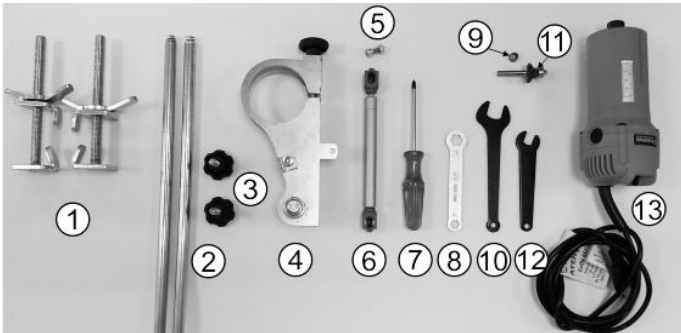
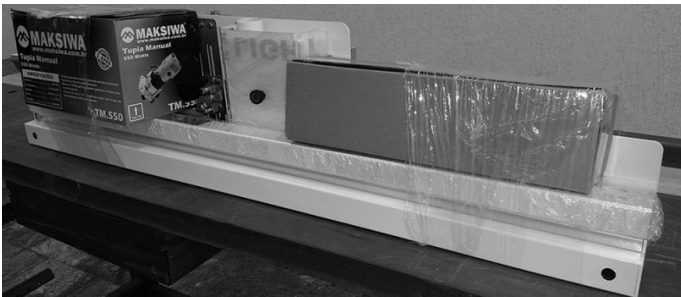

- | | |
|---------------------|----------------------|
| 1. Clamps | 8. Hex Key 10/13 |
| 2. Adjustable Guide | 9. Collet ¼ |
| 3. Knobs | 10. Hex Key 17 |
| 4. Swinging Support | 11. Cutter |
| 5. Bolt M6x16 | 12. Hex Key 10 |
| 6. Piston | 13. Trimmer / Router |
| 7. Phillips Key | |

ASSEMBLY

1. Prepare two pieces approximately with 35x15x135mm (1 3/8" x 5/8" x 5 3/8") to serve as a spacer between the setting surface and the base of the equipment:

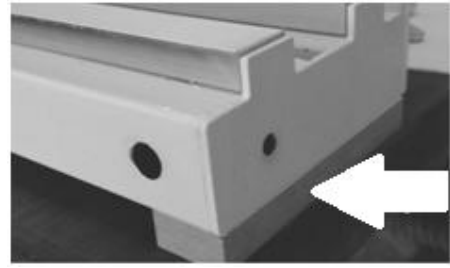

2. Choose a table or a bench for installation. Defining its position, considering that the two clamps (1) allows its fixing in any point of the center of the base or outer ends of the equipment. Note the figures below that you can also perform this setting by the side of the tables and / or benches:

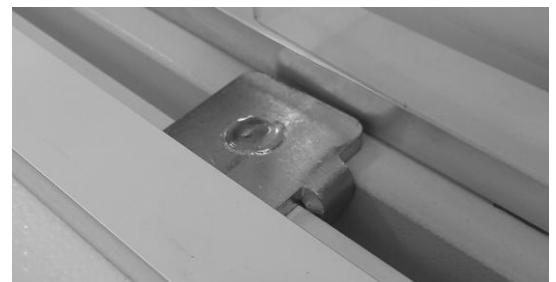

3. Assembly of Extension Table

Enter the two Adjustable Guides (2) into the holes of the main structure leaving 2 inches ends out and screw the knobs (3) by pressing them on the guides:

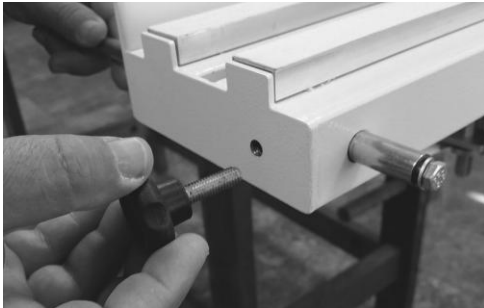

Remove the screws of the guides and insert the extension table on the guides and fix it with screws using the key 10 (8) for final tightening:



4. Swinging Support Installation

Remove the screw from the shaft of Swinging Support (4), positioning at its point of attachment to the structure and screwing tightening using the key 13 (8), as the following figures:



One of the supports of the Piston (6) is already mounted on the Swinging Support (4) and the other are the group of nut and hexagon socket screw (Allen) M6 (5) to be mounted on the upper end of the scraper set, as shown in the figure below, tightening the nut with the key 10 (8):

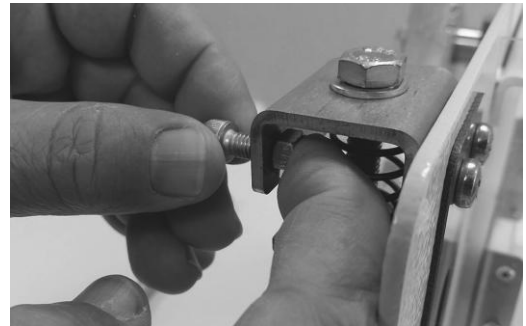

Remove the locks of the ends of the Piston (6), fitting in their respective supports and replace the locks, as the following figure:

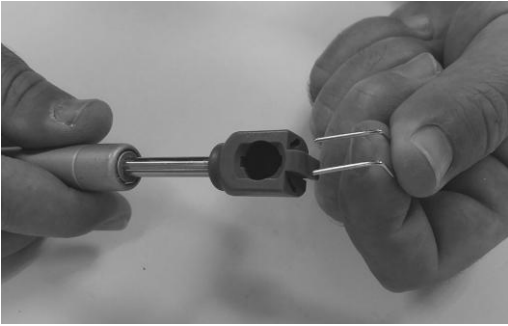

The starting point of articulation of the Swinging Support is already set at the factory, but if necessary, for adjustment should follow the instructions under "Settings" in this manual.

5. Cutter Assembly

If the cutter is with shaft $\varnothing \frac{1}{4}$ ", the original collet mounted on the shaft of the router (13), which is $\varnothing 6\text{mm}$, should be replaced. This procedure should loosen the nut from the axis router using the hex keys (10 and 12) and remove the original collet replacing it with $\frac{1}{4}$ "(9):

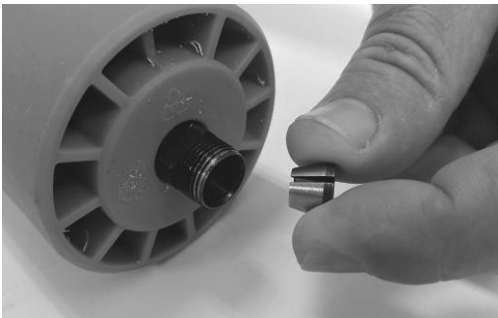
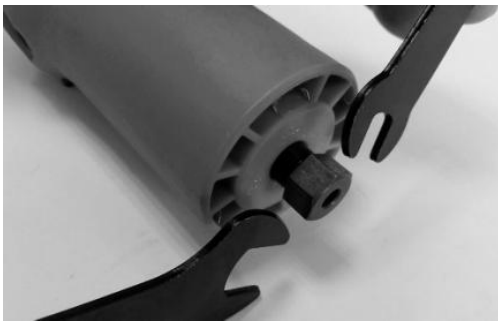

Insert the cutter on the shaft and tighten the nut again:



6. Trimmer / Router Assembly

Loosen the knob of the Swinging Support (4). Insert the router (13) with the key "ON/OFF" facing up, positioning it so that the blades of the cutter exceed approximately 1.5 mm in front of the frontal guide plate, and tighten the knob again:

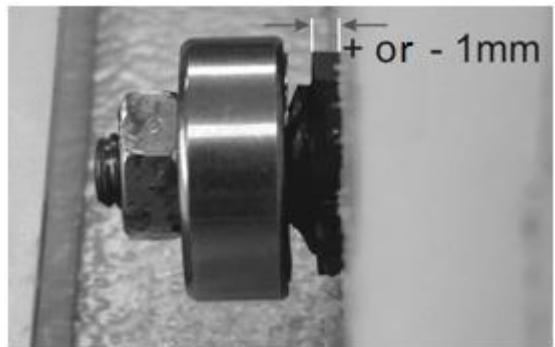

SETTINGS

The following shown adjustments must be made before using your Edge Trimmer RBB.1000 for the first time or when some kind of change is made as thick tape or thickness of the wood.



CAUTION: ANY ADJUSTMENT NEEDS TO BE MADE WITH THE MACHINE OFF AND DE-ENERGIZED (unplugged).

1. CUTTER ALIGNMENT

The horizontal alignment of the cutter was did at the factory, however, for possible adjustments, using the key 13 (8), loosen the screw of the eccentric washer and turn it until the cutter shaft center is aligned to the line of surface the sliding guide of the table:

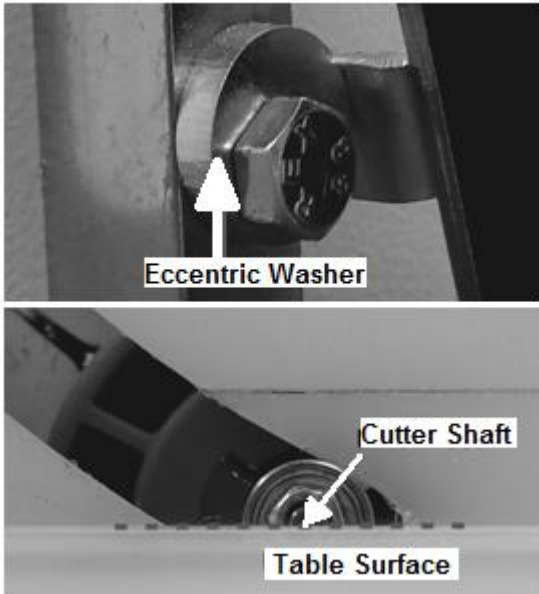

The vertical cutter alignment should be performed always the router is mounted on the swinging support, noting that the ends of the knives should exceed about 1.5 mm in front of the frontal guide:

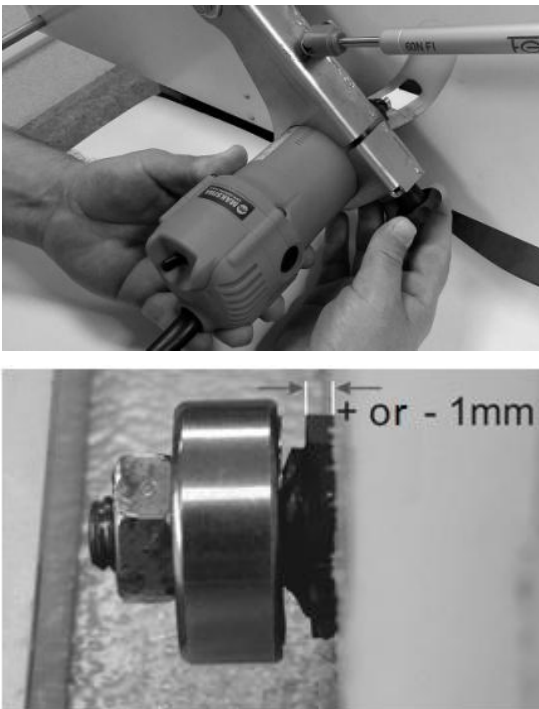

2. ADJUSTING THE SPRING OF SCRAPER BLOCK

The spring tension of the scraper block copier is set at the factory, but for any adjustments using the key 13 (8). Must loosen the lower nut shown in the figure below and rotating the screw clockwise to increase the tension and counter-clockwise to decrease tension. Retighten the nut. Obs.: This tension is applied pressing the wheel copier of scraper block over the panel surface to reproduce it, ensuring true position of the cutter along the edge.

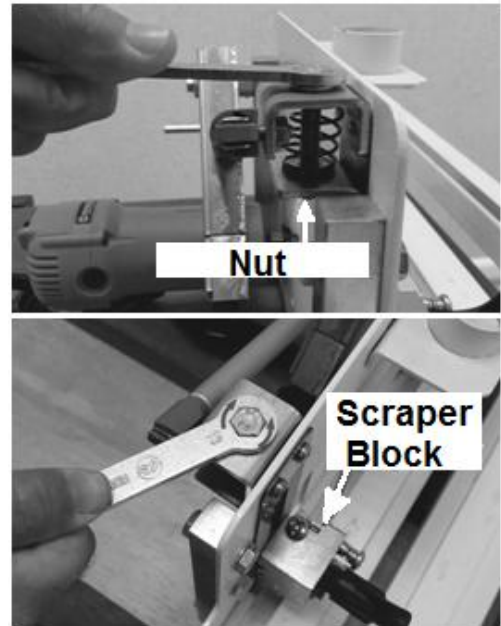

3. ADJUSTING THE SCRAPER BIT

The Scraper Bit has a special function to reproduce the final finish along the edges of the tape with a slightly rounded contour, therefore, must be carefully adjusted according to the following procedure:

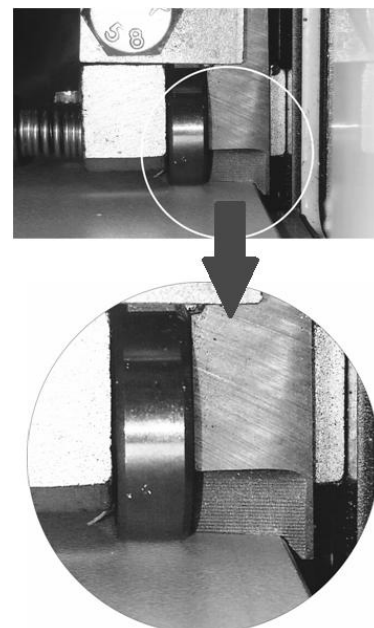

Loosen the handle knob of the scraper block and lift it then introducing model of the workpiece already with the edge tape applied and pre-trimmed by router.

Get down again the scraper resting it on the surface of the workpiece. With the left thumb exerting a light pressure on it, fixing again the handle knob:



Slightly loosen the nut of the scraper using the key 13 (8). To ensure optimal pressure of the screw in this adjustments, pull the screw with only a slight tightening torque using the fingers:



The height adjustment of the scraper bit is by the screw positioned on the top side of the scraper block using a Phillips screwdriver (7):



The vertical positioning and inclination adjustment is realized by the two screws positioned at the side of the scraper block, also using the Phillips screwdriver (7):



4. TIPS FOR A CORRECT ADJUSTMENT OF THE BIT SCRAPER:

Before beginning any procedure make sure that the copier wheel is pressed against the workpiece surface. During the adjustment procedures, always keep the side of the workpiece pressed against the side guide (guardrail).

The scraper bit has a flat part that will form a small angle with the surface of the workpiece, with the neb or contact point the edge of the workpiece.

The rounded part of the bit should edging partially around the edge of the tape, so that it forms only a small rounded arch enough to sharp the edge:

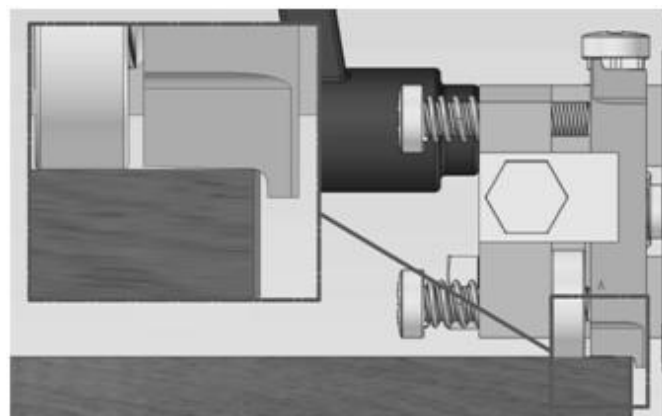

OPERATIONS

The operations made by the Edge Trimmer RBB.1000, as well as any other machine, can pose risks to the operator if the instructions in this section are not taken into account.



ATTENTION: BEFORE TURN ON NOTE IF YOUR POWER SUPPLY IS COMPATIBLE WITH THE VOLTAGE OF THE EQUIPMENT.

These instructions are written with the understanding that the operator has the knowledge and skills necessary to operate this machine. If at any time you feel difficulty performing any operation, stop using the machine. If you are an inexperienced operator, we recommend that you read books, technical papers, or seeks training from an experienced operator before performing any operation unknown. The machine must operate with all the protections and security systems that comes standard.

Above all, your safety must come first.

To get a good result at the finishing with RBB.1000 is important that the preparation of the workpiece and the collage of the edge tape have been carried out correctly. You can only work with straight cuts and straight angles (90°).

It is recommended the application of equipment for use only in pieces with edge tapes with a maximum thicknesses up to 1.0 mm.

1. EXTENSION TABLE

The extension table should be adjusted according to the width of the piece to be worked, and any position exceeding the median part of the piece width is already satisfactory.

2. PROTEÇÃO E EXAUSTÃO

In the operation area is a compartment enclosed by a transparent polycarbonate cover, which serves as a safety device, also forming an exhaust system. To activate the exhaust, just snap on your connection located above this compartment, a hose of an exhaust system or even a professional or residential vacuum cleaner.

The transparent cover must be adjusted approximately 5 to 10 mm above the surface of the workpiece.



3. SCRAPER

The scraper must be adjusted to the thickness of the piece to be worked.

Loosen the knob of the scraper block and lift it then introducing one piece or retail model to be worked. This should be without the edge tape, or if it is already with the tape that should already be pre-shaper, at least a little stretch.

Down again the scraper, resting it on the surface of the piece. With the left thumb exerting a light pressure on it, fixing it again the knob.

Then, once completed this step, the piece used for the adjustment should be removed.

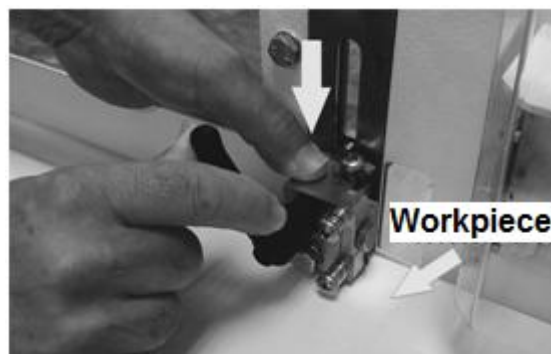

4. OPERATION

Separate the pieces to be worked, properly prepared, noting that the remains of tapes at the ends of the tops are of no more than 7 to 8 mm (5/16") and also no folds:

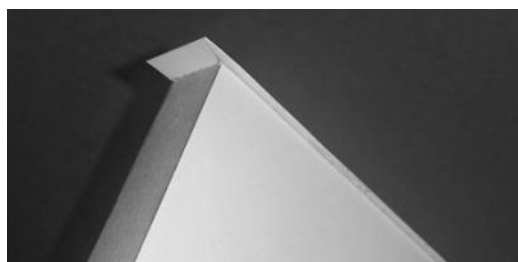

Turn on the trimmer/router through the ON/OFF switch, and when use the exhaustion system, also turn it on:



Insert on the table the piece to be worked and moves it toward the cutter and scraper, noting that the edge to be worked always keep in touch against the side guide (guard- rail). Perform this action with a rectilinear and uniform motion until the entire length of the edge pass by the scraper device:

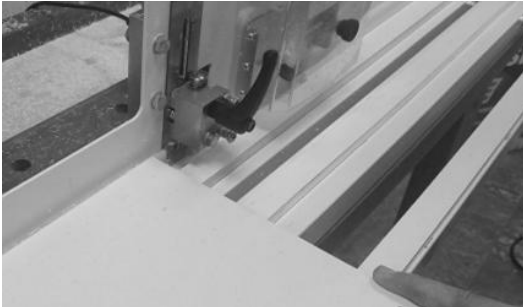

Then turn the piece and repeat the action in the opposite edge of the same tape. Repeat these actions on all edges to be worked.

At the end of the process should be cleaned the piece, removing the waste of tape from the trimming and also the remaining of glue excesses using a cloth with kerosene or other solvent.

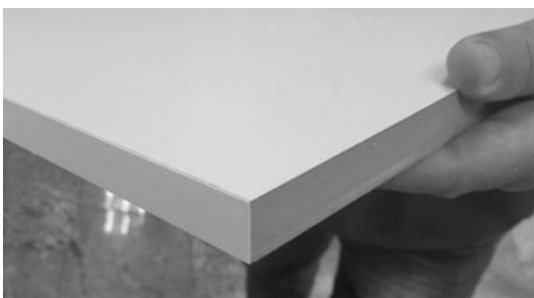

MAINTENANCE



IMPORTANT: All maintenance or cleaning on the machine must be made with the same **OFF** and **unplugged** from the outlet to prevent accidental discharges.

Periodic maintenance on your Edge Trimmer RBB.1000 MAKSIWA will ensure optimum performance. Make it a habit to inspect your equipment every time you use it.

This section covers the service adjustments or common procedures that may need to be made during the life of your machine.

Verify if the following conditions for repair or replacement are needed:

- Loosen screws.
- Switches or buttons damaged.
- Cables, plugs or sockets worn or damaged.
- Cutter and scraper bit damaged.
- Any other condition that could adversely affect the safe operation of the equipment.

CLEANING

The tape residue contaminating the bearings of the cutter and the scraper device (copiers), causing braking, which may cause marks on the surface of the piece. Is needed to clean and lubricated periodically, using lubricant spray.



Keep the table clean after each use.

Periodically (and always with the machine off) it is important to do all the cleaning of the machine, removing glue residue that could affect the proper functioning of the equipment. Clean the guides, the cutter and scraper carefully.

MAINTENANCE SCHEDULE

Daily:

- Aspirate all dust on top and around the machine.
- Clean the guides, cutter and scraper keeping clean all residue of glue and edge tape.

Weekly:

- Clean dust accumulation inside and around the machine.
- Check for wear or damage to the buttons and cord.
- Check wear on the cutter and scraper bit.

TECHNICAL ASSISTENCE

WARRANTY TERM

MAKSIWA assures the owner of his equipment, identified by the date of issue of the purchase invoice, a warranty of one (1) year, as follows:

1. The warranty period begins on the date of the commercial invoice.
2. Within the warranty period, the hand labor and the components replaced by manufacturing defect will be provided for free as long as duly proved by Maksiwa Service.
3. Third-party manufacturing equipment that makes up MAKSIWA equipment (such as motors, electrical equipment, belts etc.) are subject to the terms and conditions of warranty of their respective manufacturers.
4. In case of exchange for the warranty, please return the defective part for the manufacturer urgently.
5. Costs and risks of transport will be by the machine owner.
6. Equipment installation expenses and workplace adaptations are due to the machine owner.
7. When you notice any defect or malfunction when receiving the equipment, get in touch immediately with the manufacturer or resale. Do not turn it on.

8. Not included in this warranty technical visits aimed at cleaning or adjustments caused by wear, resulting from normal use of the equipment.

9. The warranty does not cover problems caused by mistreatment, carelessness, misuse or inappropriate use of the functions designed for this equipment in this manual, as well as poorly executed operations by untrained operators to operate it.

10. MAKSIWA is not responsible for lost productivity, direct or indirect damages caused to the owner of the equipment or to third parties, or any other expense, including lost profits.

11. Even under warranty, you may lose its validity as follows:

- a) Application of non-original components;
- b) Alteration of its original features;
- c) Lack of proper maintenance;
- d) Improper use of the equipment;
- e) Change in equipment or electronic connections;
- f) Damage caused by mechanical shock or exposure to unsuitable conditions (humidity, salt spray, corrosive agents, etc.);
- g) Damage caused by bad weather (floods, flooding, lightning, power outages etc.).

For your safety, trust the repairs, maintenance and adjustments (including inspection and replacement) for technical assistance recommended by MAKSIWA, always use genuine spare parts and accessories, reassembling to its original Edge Trimmer the same way.

Manufactured by:
Maksiwa Industria e Comercio de Maquinas LTDA.
St. Nelson Argenta, 436
Colombo – Parana – Brazil
Zipcode: 83.402-220
CNPJ: 76.670.215/0001-81
www.maksiwa.com