



Model 3160EC Easy-Close



Easy Close Feature
 Cable System (included) and
 Wide Drawer Stabilizer Kit (order separately)
 Vertical, horizontal, and front to back adjustment

APPLICATIONS:

Use in drawers and trays
 31-60 inches wide in
 retail fixtures, restaurants,
 medical facilities,
 business offices, and high
 end residential cabinetry.

3160EC Easy-Close

QUICK REFERENCE

Full Extension Undermount Slide
 Maximum Drawer width: 60"
 Even Lengths: 12"-28", 15" & 21"
 Load Rating: 100 lbs.*



QR Code:
 Installation
 Video

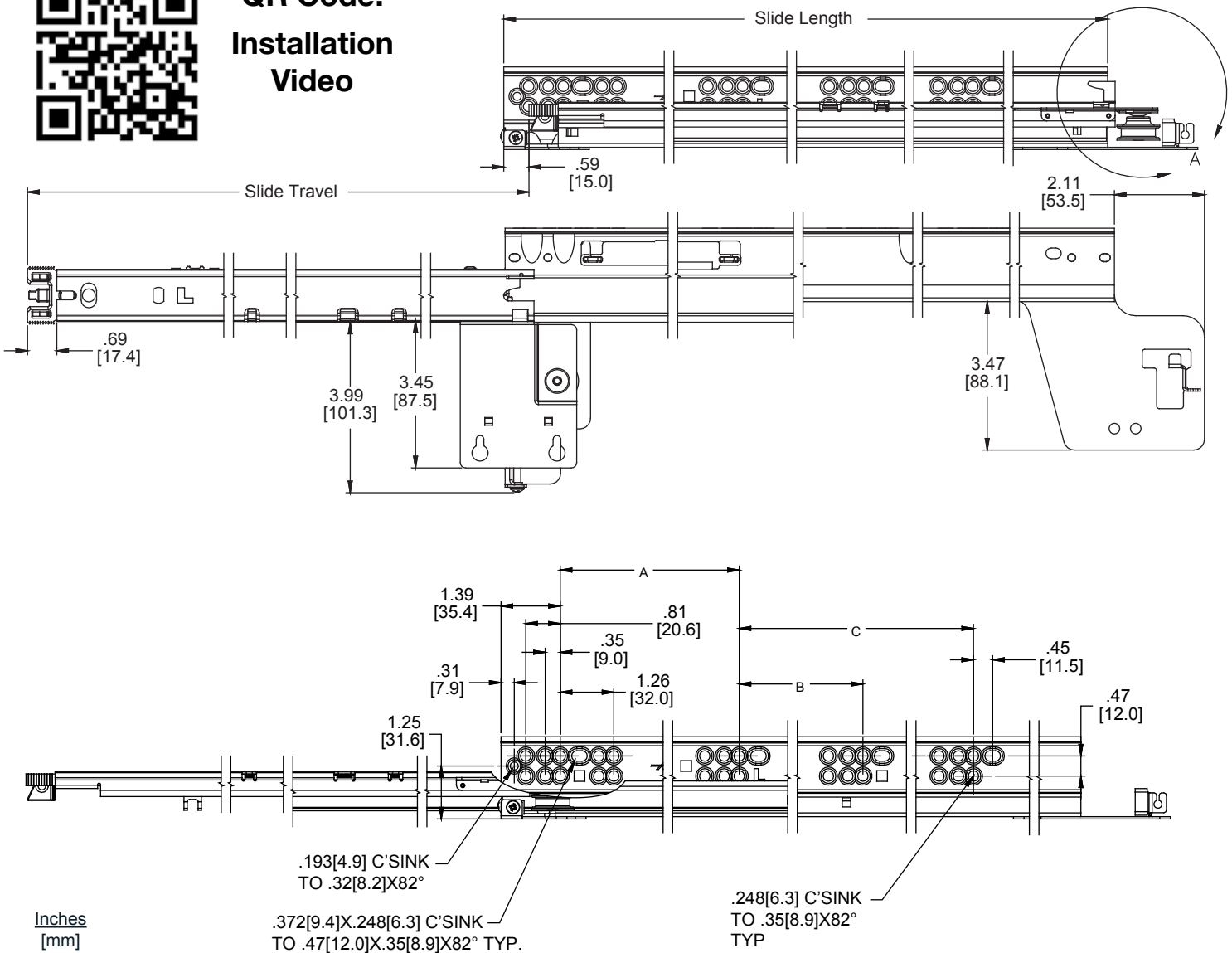

Finish: Clear electro-zinc (C)
Lengths: 12"-28" [304.8 mm-711.2 mm]
 15" and 21" [381.0mm-533.4mm]
Height: 1.05" [26.8 mm]-Under drawer
 1.87" [47.5 mm]-Overall
Load Rating: Up to 100 lbs. [45.5 kg.] per pair*
Travel: Full Extension

Mounting: Undermount (side)
Hardware: #8 Flat head screw or Flat head 6 mm Euro system screw
Bearings: Carburized Steel, polymer
Features: Compatible with 1/2" [12.7 mm] to 5/8" [15.9 mm] drawer box thickness, 1/8" [3.2 mm] range of horizontal, vertical, and front to back drawer front adjustment. Easy-Close action brings drawers to a gentle close. Out-stop silenced for quiet operation, and with cable system (included) and wide drawer stabilizer kit (order separately for drawers 41"-60") to avoid lateral movement.

Part number	Slide Length	Slide Travel	A	B	C	Drawer Depths	Cabinet Depths
C 3160-12EC	12.00 [304.8]	11.50 [292.1]	5.04 [128.0]	3.78 [96.0]	–	12.00 [304.8]	14.30 [363.2] to 16.30 [414.0]
C 3160-14EC	14.00 [355.6]	13.50 [342.9]	5.04 [128.0]	3.78 [96.0]	–	14.00 [355.6]	16.30 [414.0] to 18.30 [464.8]
C 3160-15EC	15.00 [381.0]	14.50 [368.3]	5.04 [128.0]	3.78 [96.0]	–	15.00 [381.0]	17.30 [439.4] to 19.30 [490.2]
C 3160-16EC	16.00 [406.4]	15.50 [393.7]	5.04 [128.0]	7.56 [192.0]	–	16.00 [406.4]	18.30 [464.8] to 20.30 [515.6]
C 3160-18EC	18.00 [457.2]	17.50 [444.5]	5.04 [128.0]	7.56 [192.0]	–	18.00 [457.2]	20.30 [515.6] to 22.30 [566.4]
C 3160-20EC	20.00 [508.0]	19.50 [495.3]	8.82 [224.0]	7.56 [192.0]	–	20.00 [508.0]	22.30 [566.4] to 24.30 [617.2]
C 3160-21EC	21.00 [533.4]	20.50 [520.7]	8.82 [224.0]	7.56 [192.0]	10.08 [256.0]	21.00 [533.4]	23.30 [591.8] to 25.30 [642.6]
C 3160-22EC	22.00 [558.8]	21.50 [546.1]	8.82 [224.0]	10.08 [256.0]	–	22.00 [558.8]	24.30 [617.2] to 26.30 [668.0]
C 3160-24EC	24.00 [609.6]	23.50 [596.9]	8.82 [224.0]	10.08 [256.0]	–	24.00 [609.6]	26.30 [668.0] to 28.30 [718.8]
C 3160-26EC	26.00 [660.4]	25.50 [647.7]	8.82 [224.0]	10.08 [256.0]	13.86 [352.0]	26.00 [660.4]	28.30 [718.8] to 30.30 [769.6]
C 3160-28EC	28.00 [711.2]	27.50 [698.5]	8.82 [224.0]	10.08 [256.0]	13.86 [352.0]	28.00 [711.2]	30.30 [769.6] to 32.30 [820.4]

* Load rating based on 22" slides installed in a 60" wide drawer cycled 50,000 with carrier strip installed.

Installation Instructions

Build drawer and cabinet based on dimensions shown.

Drawer side thickness	5/8" [16]	19/32" [15]	9/16" [14]	1/2" [13]
For outside drawer width (deduct from inside cabinet width)	1/2" [13]	9/16" [14]	5/8" [16]	3/4" [19]
For inside drawer width (deduct from inside cabinet width)	1 3/4" [44.5]			

Maximum drawer height equals cabinet opening height minus 13/16" [20.6 mm]. Recommended drawer bottom inset 1/2" max.

General information shown in Figure 1.

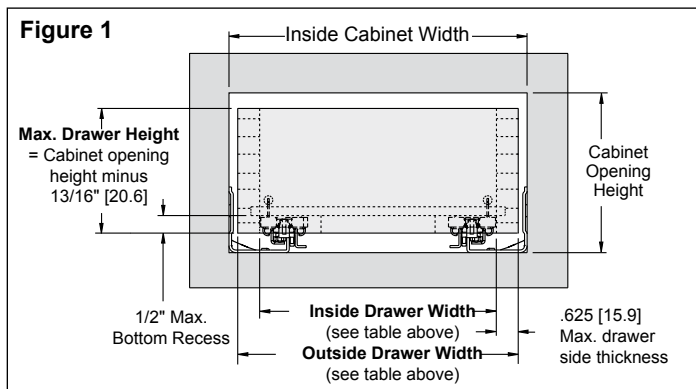

Drawer Depth equals slide length. General information shown in Figure 2.

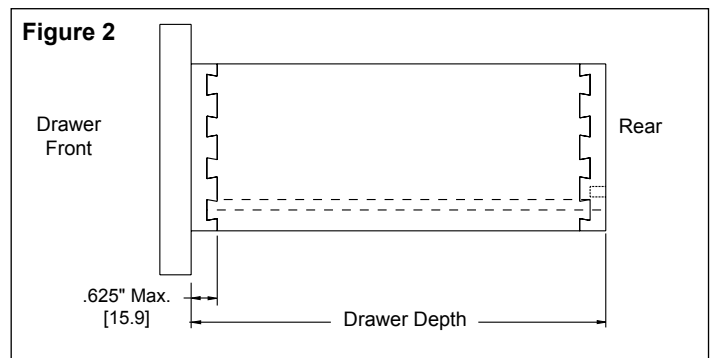

Drawer Preparation

Notch drawer back flush with drawer bottom to provide clearance for slides as shown in Figure 3.

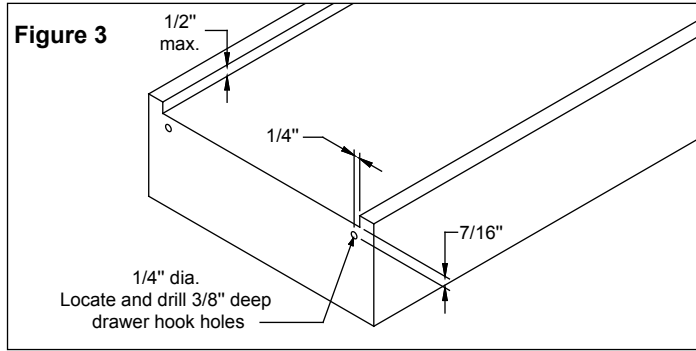

Pre-drill four holes for disconnect handle assemblies at 10° angle from bottom panel (Figure 4).

Pre-drill two holes for slide hooks as shown in Figure 3.

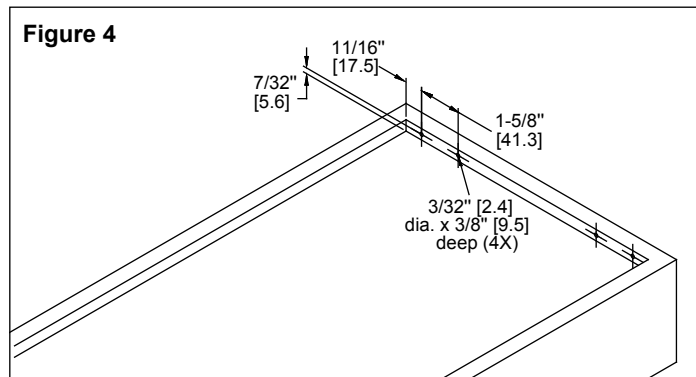

Install both disconnect levers to bottom of the drawer. Levers should curve toward the center of the drawer.

Place disconnect handles against each inside corner of the drawer bottom and install with #6 pan head screws as shown in Figure 5. For 1/2" drawer thickness install the included spacers along with the disconnect handles as shown in Figure 5A.

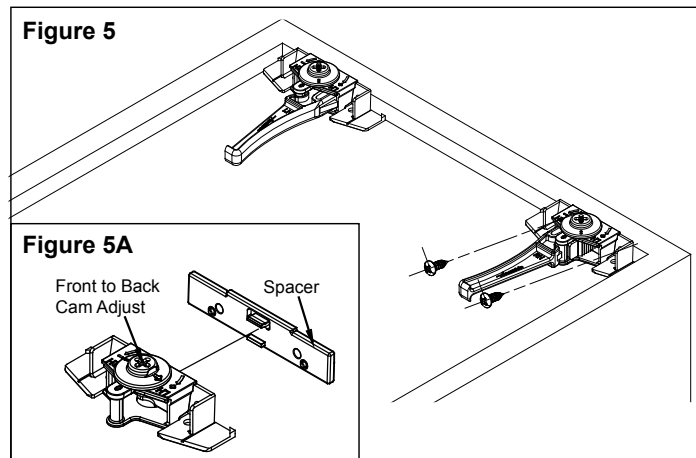

For drawers with bottom panels flush to the drawer subfront, vertical screw holes are available in the same handle kit as shown in Figure 5B.

NOTE: The optional drill jig can be used to mark the notch and pre-drill holes on the drawer. PN 4180-0568-XE

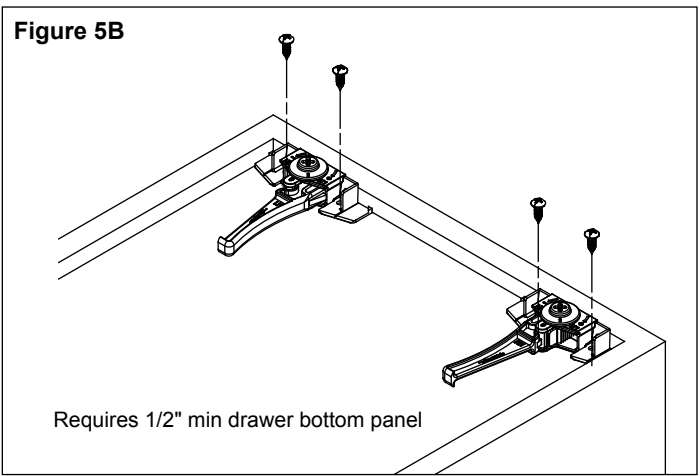

Cabinet Member Installation

Frameless Overlay Installation

If needed, pre-drill a hole 37 mm from cabinet front. The optional drill jig can be used to pre-drill this hole and/or pencil mark line in the 37 mm location from the cabinet front.

For location of additional screw holes refer to the tabulated data on front page.

Install slides to cabinet wall with #8 x 5/8" flat head screws.

Align slide member hole shown to pre-drilled hole 37 mm from front of cabinet to ensure proper gap. A minimum of 3 screws are recommended for each side.

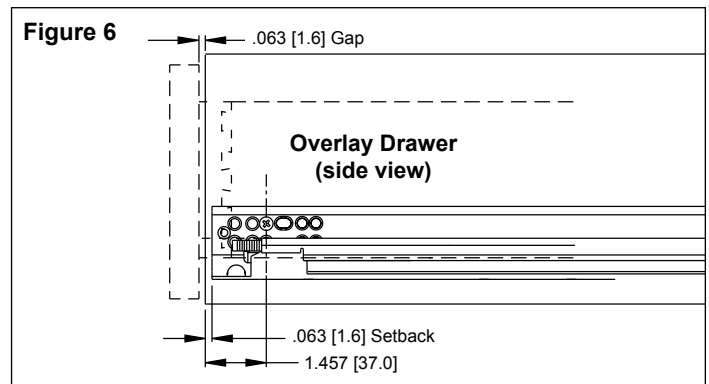

Frameless Inset Installation

Align slide member hole shown to pre-drilled hole 37 mm from front of cabinet for 5/8" drawer box thickness. Install slides to cabinet wall with #8 x 5/8" flat head screws. See Figure 7.

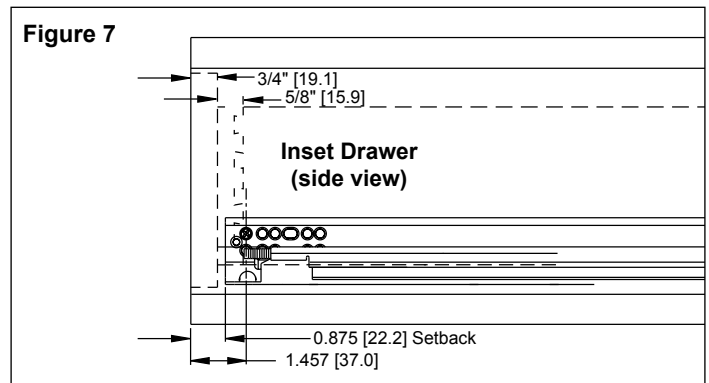

For general component identification see Figures 8 and 9.

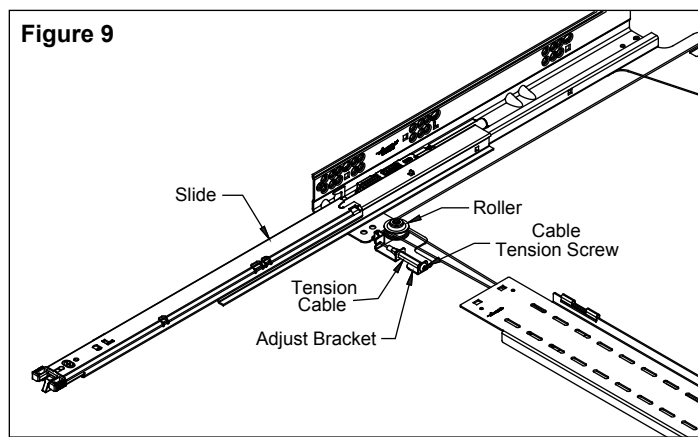
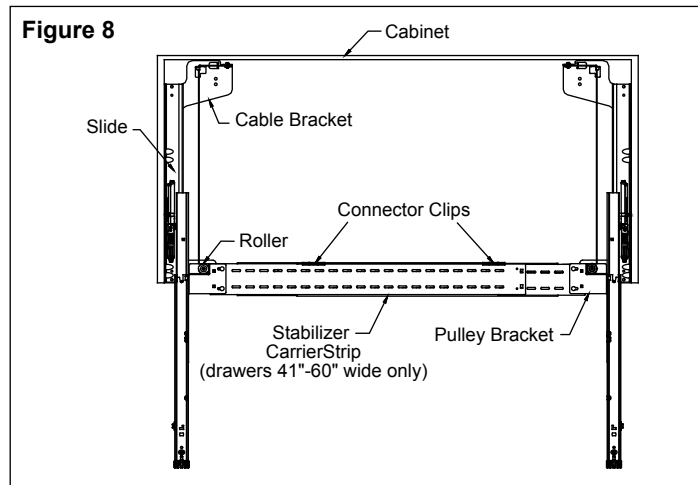

Assemble Stabilizer Carrier Strip

Two stabilizer carrier strips are provided in the wide drawer stabilizer kit, attach connector clip using #8 screws. See Figure 10.

1. Align the two carrier strips so the Accuride logo is at the top. Flip the top one over, so the logos face each other. Extend the strips. See Figure 10.
2. Install two #8 screws on the top of the assembly stabilizer carrier strips (only partially tightening the screws), see Figure 10. Repeat action on opposite side.

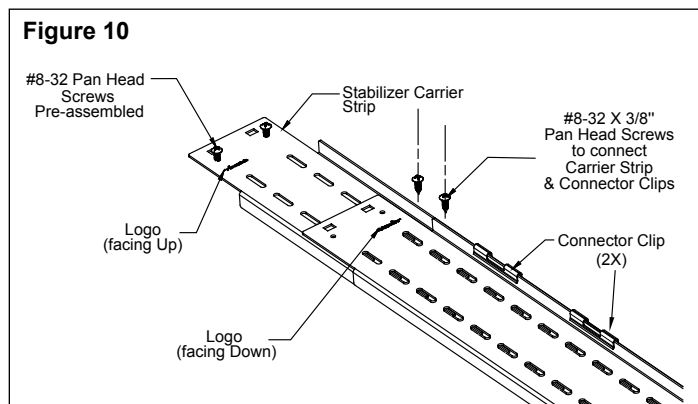

3. Snap connector clips into position (to hold strips together) as shown on Figure 10, and align the assembly to pulley bracket plates (check fit), see Figure 11.

4. With the slides in the closed position, placed the stabilizer carrier strip assembly under the pulley bracket, and insert the partially installed mounting screws through the keyhole slots, see Figure 11.

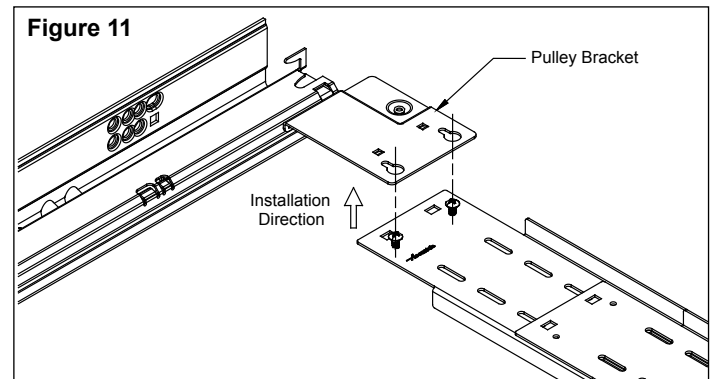

5. Expand the assembly into position and fully tighten the screws to secure stabilizer carrier strip to the pulley bracket.
6. Position the connector clips (where carrier strips overlap) and fasten with the remaining #8 x 3/8" pan head screws.
7. Complete installing by supporting, with upward bow, the stabilizer carrier strip while tightening the two #8 screws to secure pulley bracket & stabilizer carrier strip.

Install Cable System (included)

1. Start on the right hand side. Uncoil cable and route it through the back bracket along the roller system as shown in Figures 12 and 13.

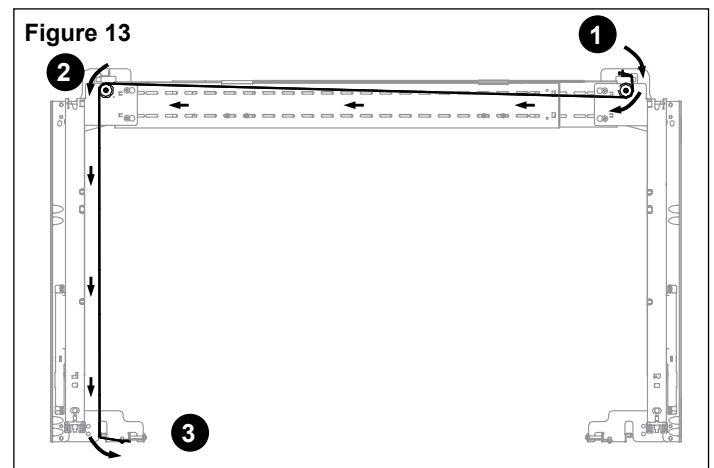
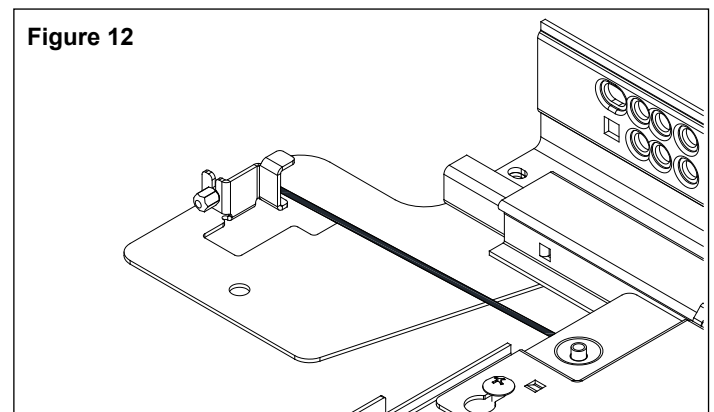

- Slides need to be in the closed position. Once you reach the front bracket, pull the cable until an 1/8" gap is achieved as shown in Figure 14.

Figure 14

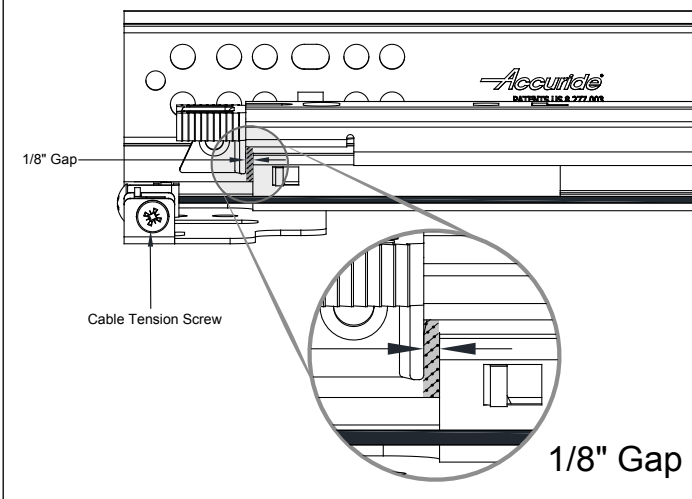

- Once gap is achieved pass cable through slot and wrap under the cable locking screw. Then turn Cable tension screw until gap is closed. Make one additional full turn as shown in Figures 15 and 16. Cut excess cable.

Figure 15

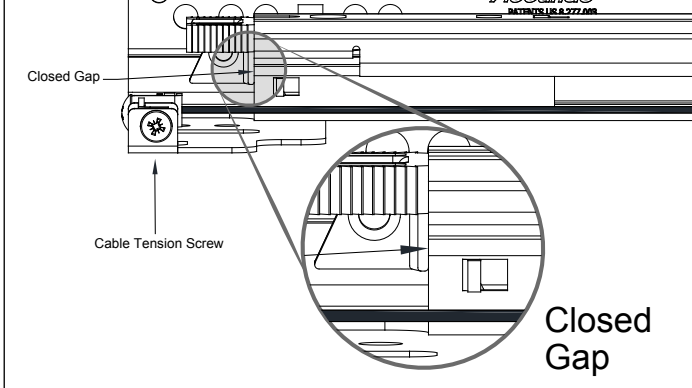
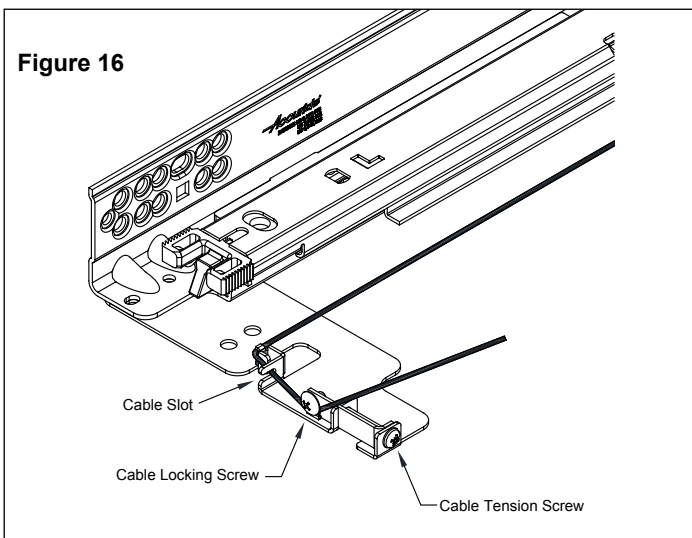
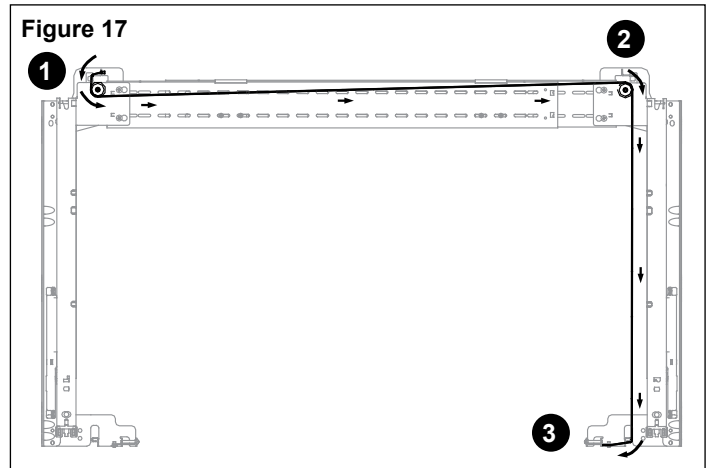

Figure 16



- Repeat steps 1-3 on the opposite side. See Figure 17.

Figure 17



- After installing both cables open the slides to their fully extended position to check movement.

NOTE: Too much tension will cause poor movement, ensure both cables are in pulley's groove after tightening. Adjust tension in order to have a combination of optimal movement and lateral stability, and then cut the cables to size.

Drawer Installation and adjustments

- Extend slides fully. Lower the drawer onto the slides and push until the levers lock onto the front of the slides. Continue to push until the drawer "ratchets" in completely.
- If the drawer doesn't close fully check to ensure the rear hooks on the slide fit into the rear holes of the drawer, see Figure 18 and 19.

Figure 18

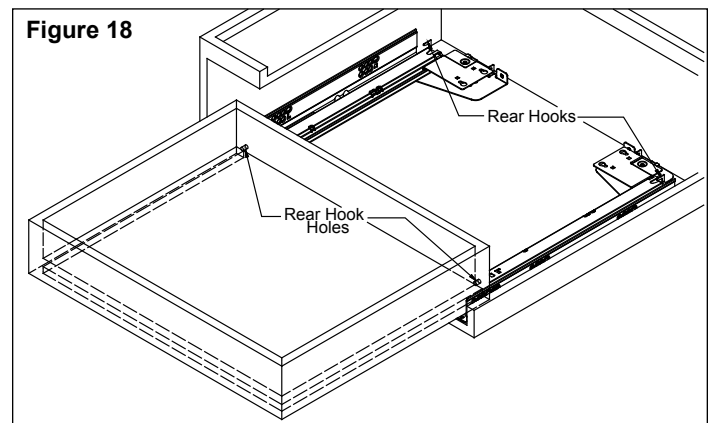
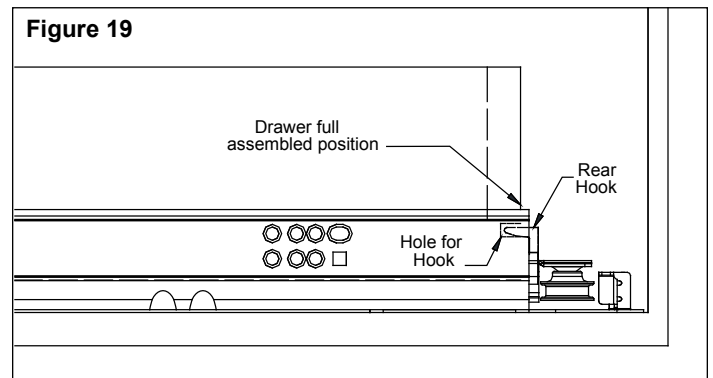
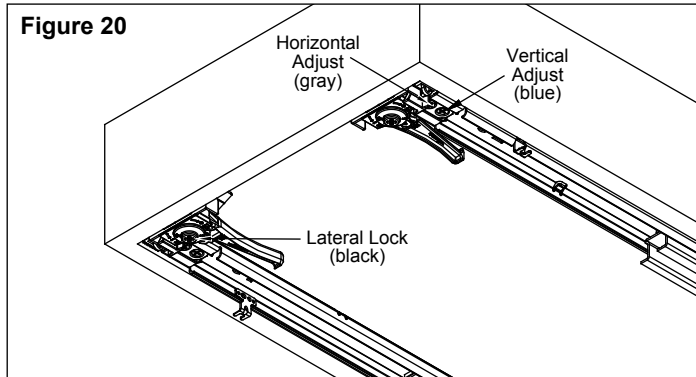

Figure 19



NOTE: Prior to making any drawer adjustment, loosen the black 1/4-turn lateral lock (on the left side of the drawer member) by turning it counterclockwise.

- On slide drawer member, adjust horizontal and vertical position of drawer front by rotating the corresponding cam with a #2 Phillips or #2 pozi screwdriver. To secure drawer front position, lock the drawer position by turning the 1/4-turn black lateral lock clockwise 1/4-turn, see Figure 20.



- Adjust front and back position of the drawer by rotating the disconnect lever cam with a #2 Phillips or #2 pozi screwdriver, see Figure 21.

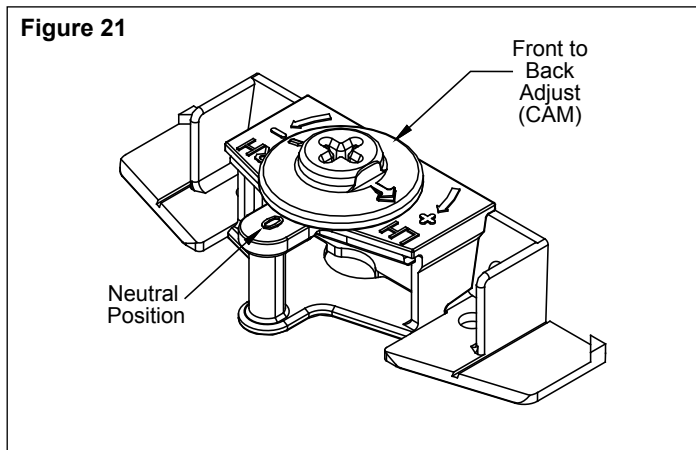

- Tighten all the previously partially tighten screws, adjust cable tension by tightening the cable tensioning screw see Figure 10 for reference.

Complete your order for Accuride model 3160EC by specifying the following:

	100 Pairs	C	3160	-18	EC	D
Total Required Slides	_____	_____	_____	_____	_____	_____
Slide Finish	_____	_____	_____	_____	_____	_____
Model Number	_____	_____	_____	_____	_____	_____
Slide Length	_____	_____	_____	_____	_____	_____
Easy-Close Feature	_____	_____	_____	_____	_____	_____
Single Pair Packaging	_____	_____	_____	_____	_____	_____

To complete your order for model 3160EC for installations with drawers from 41" to 60" you must order a wide drawer stabilizer kit by specifying the following:

4180-0753-XE

- 2 Stabilizer Carrier Strips
- 3 Connector Clips
- 8 #8 x 3/8" Pan Head Screws for Adjuster Carrier Strip Installation

Additional Bracket kits not available.

Specifications

Slide Members: Cold rolled steel
 Ball Retainers: Polymer
 Ball Bearings: Carburized steel and polymer
 Rollers: Polymer

RoHs Compliant

NOTE: Specifications, materials, prices, terms, and delivery are subject to change without notice.

Packaging

Distributor (D) Pack

All lengths are packaged 1 pair per box, box includes one pair of slides with six #8 x 5/8" Phillips flat head screws (for slides), 2 each standard horizontal and vertical lever disconnects, and four #6 x 5/8" Phillips pan head screws (for levers).

Disconnect Lever

Standard Horizontal and Vertical Lever Disconnect (P/N 4180-0747-XE)

One pair of individually package with 4 ea. #6 x 5/8" Phillips pan head type 17s in a polybag.



ACCURIDE INTERNATIONAL INC.

12311 Shoemaker Avenue
 Santa Fe Springs, CA 90670

TEL (562) 903-0200

FAX (562) 903-0208

www accuride.com

Manufacturing, Engineering, and Sales

United States • Germany • Japan • Mexico • United Kingdom • China