

SÉRIE 30141100 FLUSH-SURFACE  
 FEUILLE D'INSTALLATION  
 30141100 FLUSH-SURFACE SERIES  
 INSTALLATION SHEET

1. Installation

1. Visser les braquettes à la surface désirée.

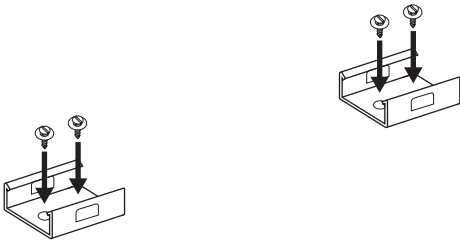

2. Insérer la barre profilée dans les braquettes.

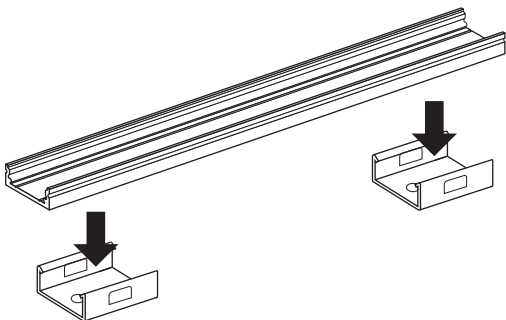

1. Installation

1. Screw the brackets to the desired surface.

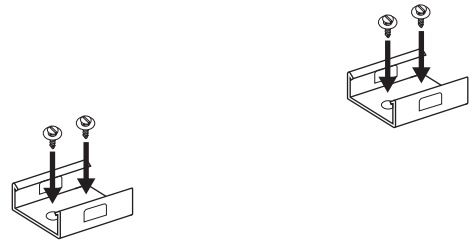

2. Clip the profiled bar into the brackets.

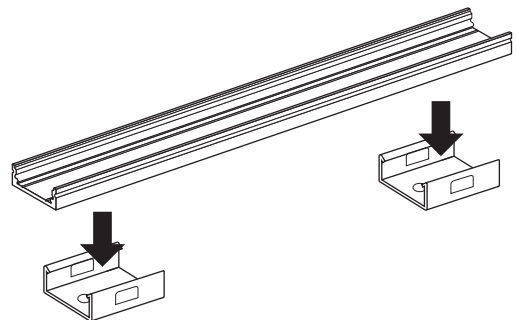

Safe, Fast and Easy to install with the EZLED POWER  
 Installation simple et rapide avec le système de connexion  
 EZLED POWER



## 1. Installation

3. Appuyer et coller le ruban DEL (suivre les guides pour le 10 mm)  
Acceptera un ruban DEL 14 mm de large maximum.\*

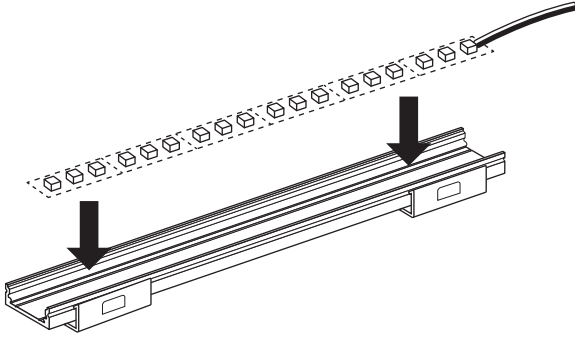

4. Mettre la lentille en place.

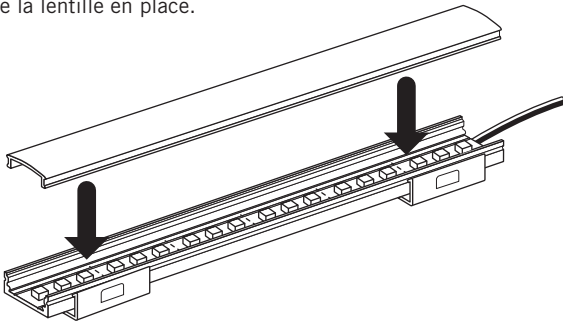

5. Glisser les embouts en place.

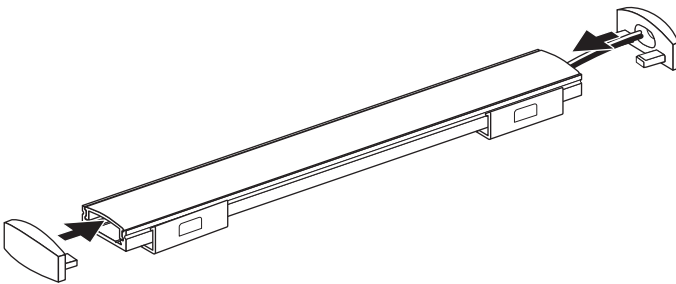

### Mise en garde

1. Utiliser seulement des composants Certifiées Classe 2 n'excédant pas 30VCC ou 15VAC lors d'une installation dans un endroit mouillé ou 60VCC ou 42.4V ca maximum lors d'une installation dans un endroit sec ou humide.
2. Ne pas dépasser 5 ampères pour respecter les normes classe 2.

CLASSE  
2

100W  
MAX

4 AMP MAX  
↓ 24V

5 AMP MAX  
↓ 12V

\* Les rubans DEL sont vendus séparément.

## 1. Installation

3. Press and glue the LED Strip Tape into place (follow guides for the 10 mm strip). Will accept a 14 mm wide strip maximum.\*

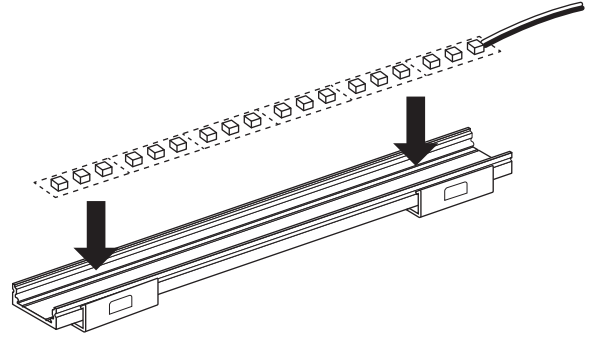

4. Clip the lens into place.

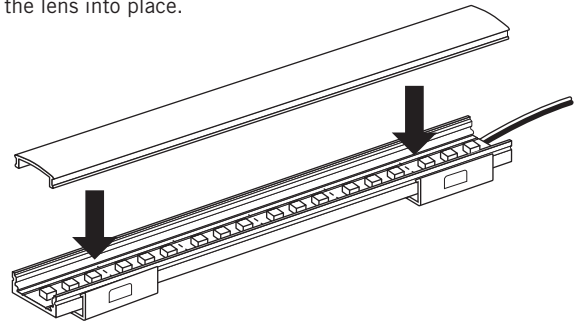

5. Slide the encaps into place.

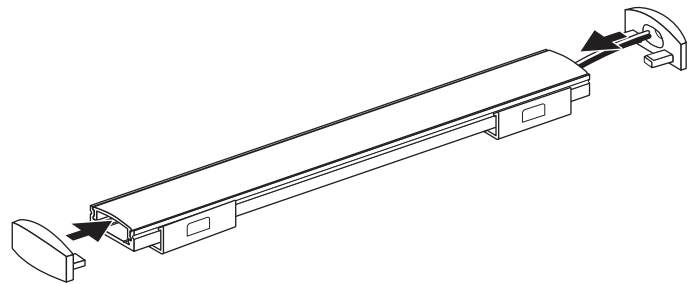

### Warning

1. Use only Class 2 rated components not exceeding 30VDC or 15VAC when installing the outline lighting in wet locations or 60VDC or 42.4V peak ac when installing the outline lighting in a dry or damp location.
2. Do not go over 5 amps to match class 2 requirements.

CLASS  
2

100W  
MAX

4 AMP MAX  
↓ 24V

5 AMP MAX  
↓ 12V

\* The LED strips are sold separately.