

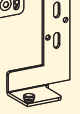









Beschlägegarnituren inkl. Einbauanleitung
Garnitures de ferrure instructions de montage comprises
Fitting sets incl. mounting instructions

mod. GR 25 kg	
	Paar paire pair 1 x
	Paar paire pair 1 x
	Set à 4 Stk. 1 x
	1 x
	1 x
	2 x
Bestell-Nr./no. d'article/ordering code	
einzelverpackt emballées séparément packing per one set	056.3081.171

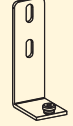
mod. H 25 kg	
	2 x
	2 x
	1 x
	1 x
	2 x
Bestell-Nr./no. d'article/ordering code	
einzelverpackt emballées séparément packing per one set	056.3077.171

Profile und Einzelteile (Verpackungseinheiten beachten)
Profils et pièces détachées (tenir compte du conditionnement resp. des unités de vente)
Profiles and components (packing quantities see below)

Zubehör / Accessories / Accessoires

Einfachlaufschiene, Alu eloxiert, gelocht

Single top running track, aluminium anodized, pre-drilled
Rail de roulement simple, en alu anodisé, perforé

Gr./Size	Art. No./Cat. No.
2500 mm	056.3041.250
3500 mm	056.3041.350
6000 mm	056.3041.600

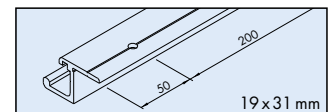

Einfachführungsschiene, Alu, gelocht

Single guide track, aluminium, pre-drilled
Rail de guidage simple, en alu, perforé

Gr./Size	Art. No./Cat. No.
2500 mm	056.3079.250
3500 mm	056.3079.350
6000 mm	056.3079.600

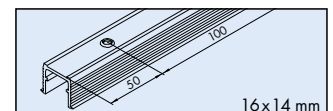

Glas-Rahmenprofil, Alu eloxiert

Glass frame profile, aluminium anodized
Profil de cadre à verre, en alu anodisé

Gr./Size	Art. No./Cat. No.
2500 mm	056.3070.250
3500 mm	056.3070.350
6000 mm	056.3070.600

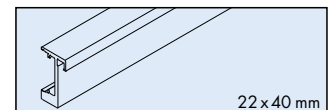

Dichtungsprofil, Kunststoff grau, für Glas-Rahmenprofil

Sealing profile, plastic grey, for glass frame profile
Profil d'étanchéité, en plastique gris, pour profil à cadre en verre

Gr./Size	Art. No./Cat. No.
2500 mm	040.3061.250

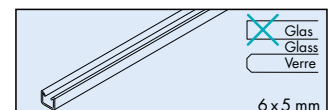

Zwischenstopper, Kunststoff grau

Intermediate stop, plastic grey
Butée intermédiaire, plastique gris

Gr./Size	Art. No./Cat. No.
5x	056.3049.081

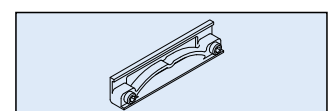

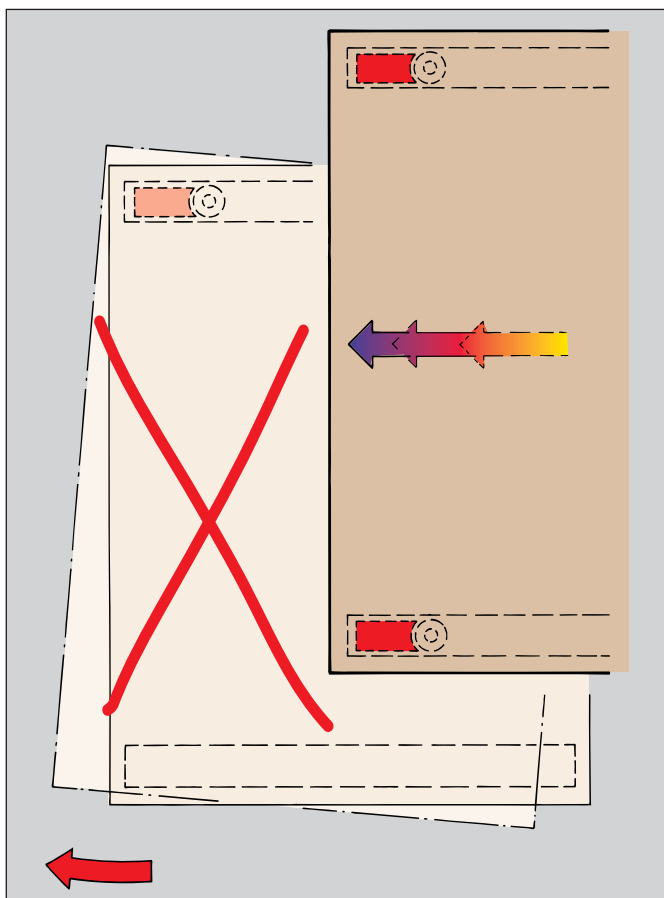

Hohe Betriebssicherheit dank 4-Punkt-Führung und 4-Punkt-Stopfung

Sécurité élevée grâce au guidage et stoppage 4 points
Thanks to 4 point guide system we achieve high operational safety and reliability

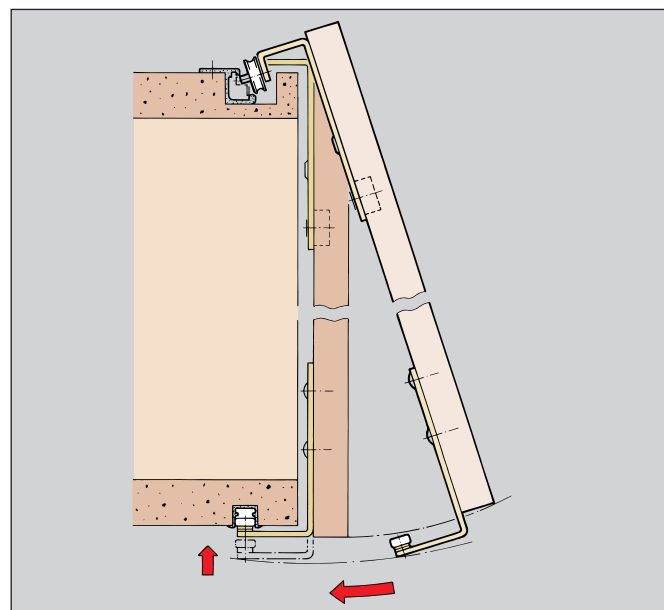

Einfache Türmontage

Montage simple de la porte
Easy mounting of the doors

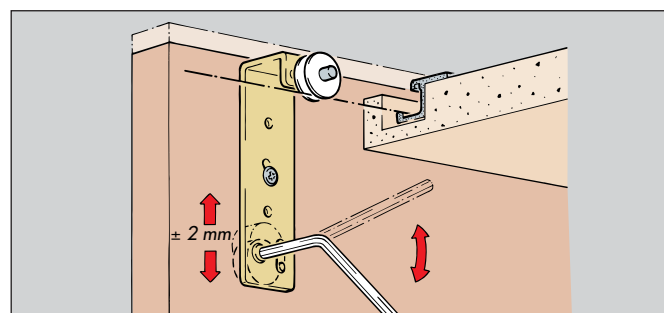

Exzenterhöhenverstellung

Réglage de la hauteur par excentrique
Eccentric bush height adjustment

Einsatzideen / Idées de montage / Applications

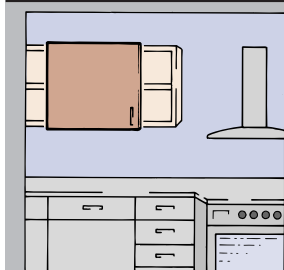

Küche/cuisine/kitchen

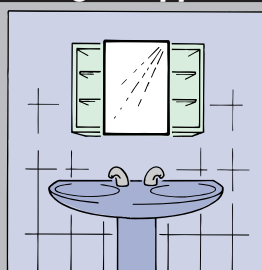

Bad/bain/bath

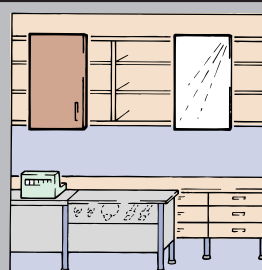

Laden/magasin/shop

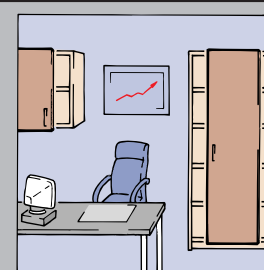

Büro, Wohnen/bureau/office

Technische Daten

- Flügelgewicht max. 25 kg
- Türstärken Holz 19 - 26 mm
- Türstärke Glas 4 mm
- Laufwerke mit kunststoffummanteltem Kugellager (KL)

Technische Änderungen vorbehalten

Caractéristiques techniques

- Poids du vantail max. 25 kg.
- Epaisseur de la porte en bois 19-26 mm
- Epaisseur de la porte en verre 4 mm
- Galet à roulement à billes plastifié (KL)

Sous réserve de modifications techniques

Technical data

- Door weight max. 25 kg
- Door thickness wood 19-26 mm
- Door thickness glass 4 mm
- Plastic clad ball bearings (KL)

Subjected to technical modifications

Nutzen Sie unsere technische Unterstützung für spezielle Schrank-Konstruktionen!

Nous vous conseillons volontiers pour toute construction spéciale

Make use of our technical support for special cabinet designs

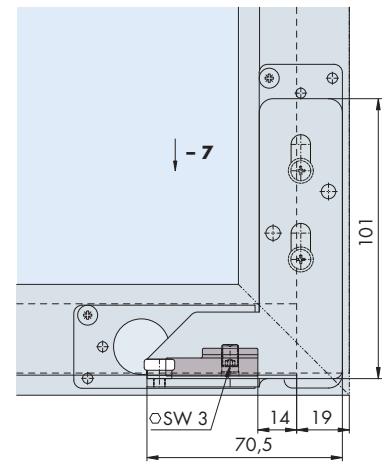
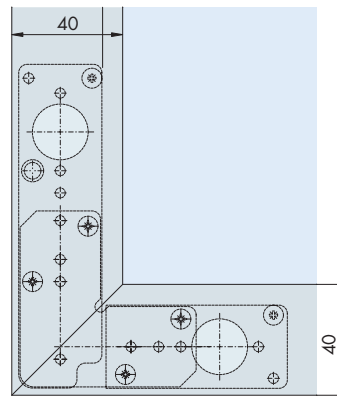
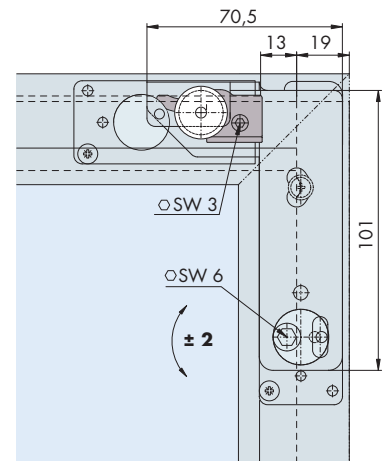
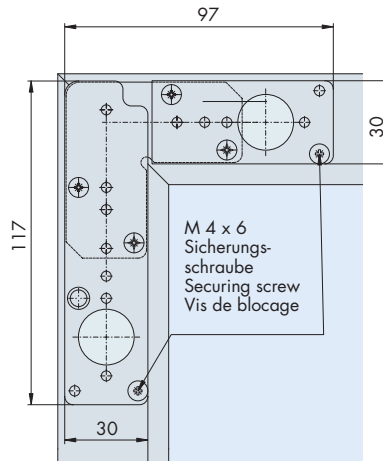
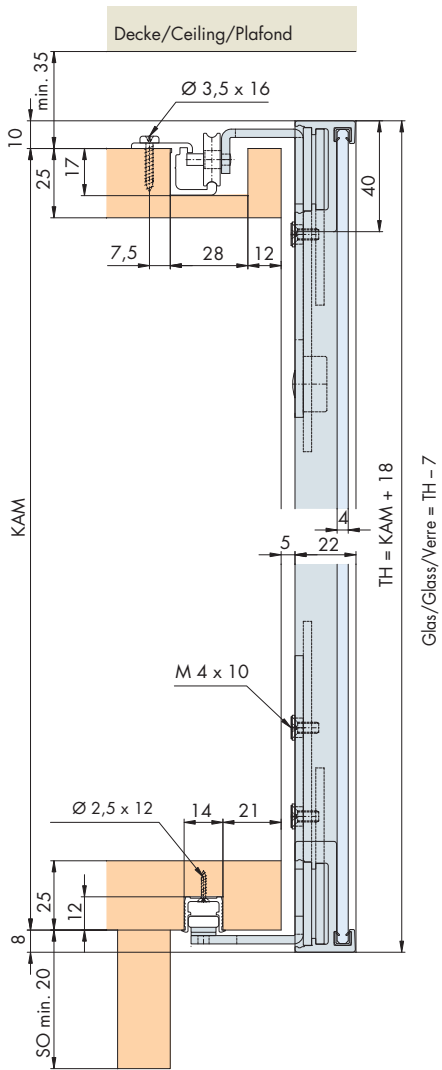

GR

für Glas-Schiebetüren mit Alu-Rahmenprofil

pour portes en verre coulissantes à cadre

for framed glass sliding doors

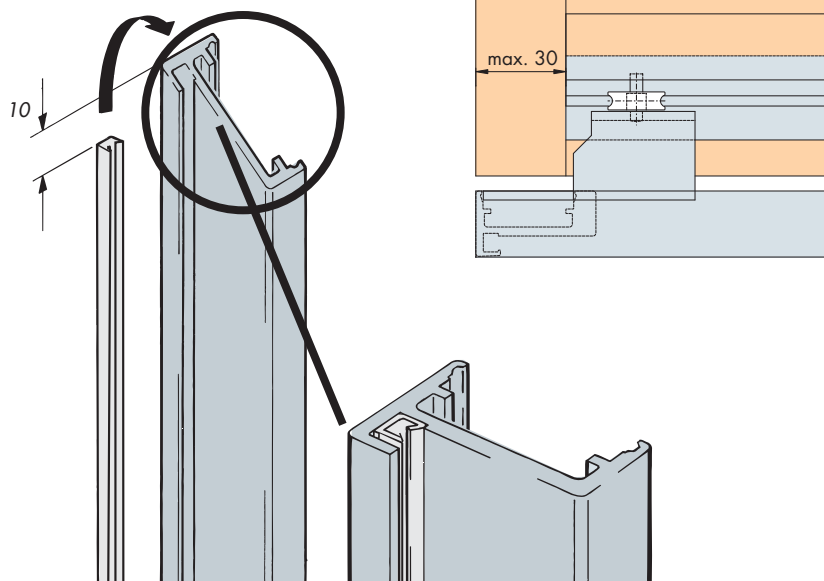

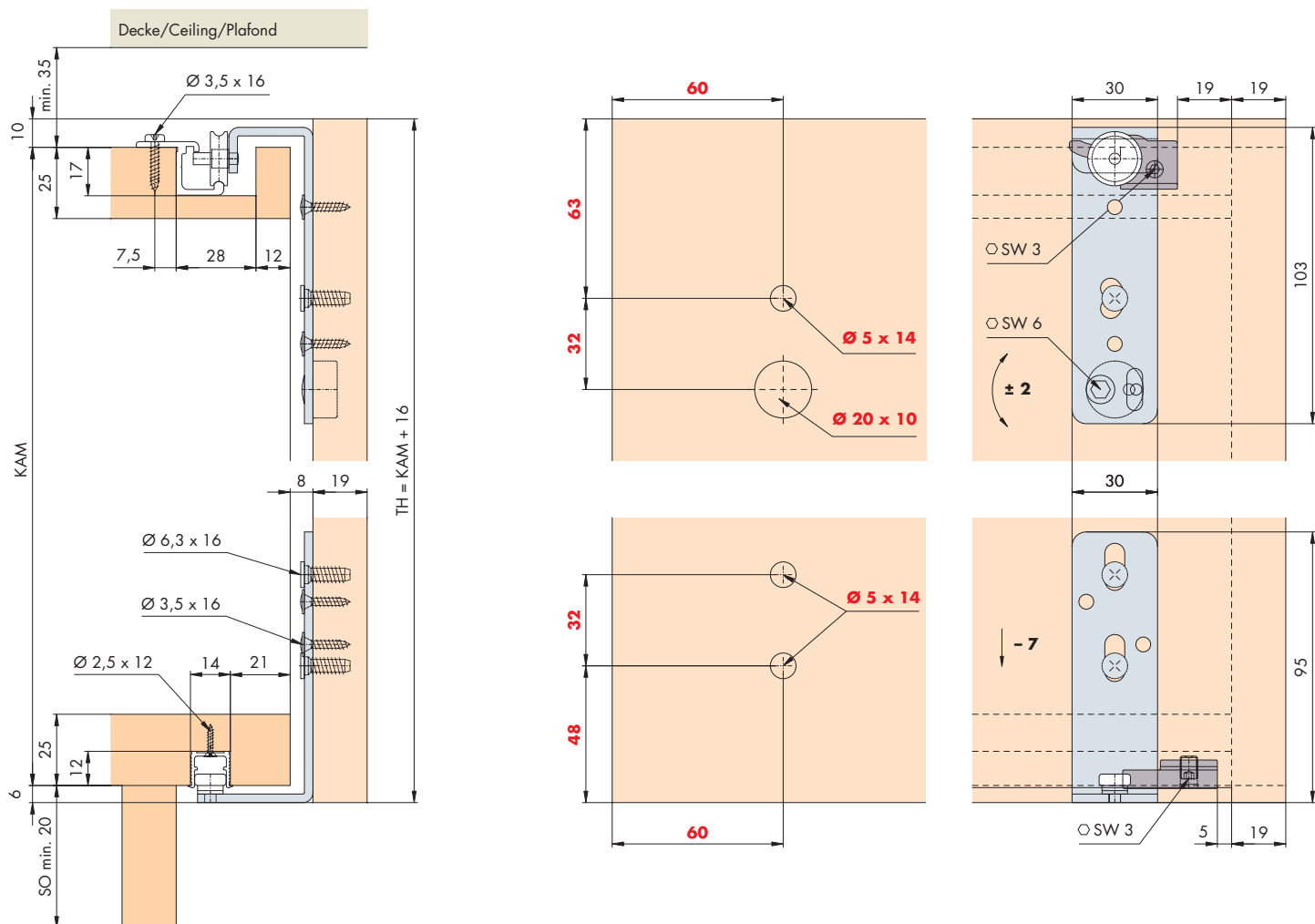

H

für Holz-Schiebtüren

pour portes en bois coulissantes

for wooden sliding doors

Wichtige Montagehinweise:

Laufschiene inwendig reinigen. Stopper vor der Schienenmontage einsetzen. Stopper müssen oben und unten gleichzeitig anschlagen. Nach der Höhenjustierung alle Vorbefestigungsschrauben festziehen und alle zusätzlichen Sicherungsschrauben anbringen.

Important:

Nettoyer l'intérieur du rail de roulement. Mettre les butées avant de monter le rail. Le contact des butées doit être simultané en haut et en bas. Après avoir ajusté la hauteur, serrer toutes les vis de fixation et mettre toutes les vis de blocage supplémentaire.

Important notes for mounting:

Always clean inside of tracks. Stoppers to be inserted before mounting of the track. Top and bottom stoppers must be hit at the same time. After height adjustment is completed tighten up all temporarily fixed screws and fit all additional securing screws.