



Nº OF DOORS
x KIT



INLAY
DOOR SYSTEM



BYPASS
DOOR SYSTEM



MAX DOOR
WEIGHT



DOOR
THICKNESS

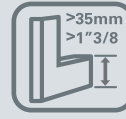

MIN DOOR
FRAME HEIGHT



DOOR
MATERIAL

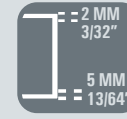

GAP DOOR-TRACK
GAP DOOR-FLOOR



CENTRAL DRIVE
TECHNOLOGY

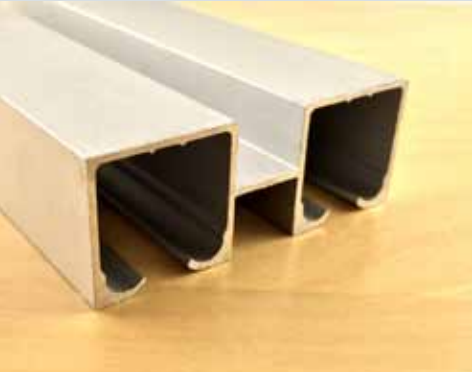

Track U45DRT AL



Carrier DN 50 Clip



Balanced
Movement



Encapsulated
Ball Bearings

Height
Regulation

DESCRIPTION

- Top sliding system for wood doors up to 50 kg (110 lbs).

APPLICATIONS

- Ideal for closet applications.

FEATURES

- The Clip-on installation feature provides a fast and easy mount and dismantling of the door.
- The doors can be delivered to the jobsite ready to be installed.
- Our new Central Drive Technology encapsulates the ball bearings in the body of the carrier, transmitting a balanced movement to the wheels and ensuring major protection against dust, grime and other external agents.
- Extremely quiet movement due to the central drive technology.
- Minimum gap between the door and track (2mm - 3/32").
- Stoppers with retention device installed inside the track will retain the door in position.



SALINITY
TEST



ANSI-BHMA *



ROLLER



DOOR THICKNESS
20-35mm - 25/32" - 1 1/8"

NEW! AVAILABLE
MAY 2014

TRACK U45DRT SMOOTH AL

PART NUMBER	DESCRIPTION
• 021U45DRT351	Track U45DRT Smooth Double AL 2m (6.5 ft)
• 021U45DRT352	Track U45DRT Smooth Double AL 3m (9.85 ft)
• 021U45DRT35-08	Track U45DRT Smooth Double AL 8 ft
• 021U45DRT35-12	Track U45DRT Smooth Double AL 12 ft

MASTER PACK: 4 units

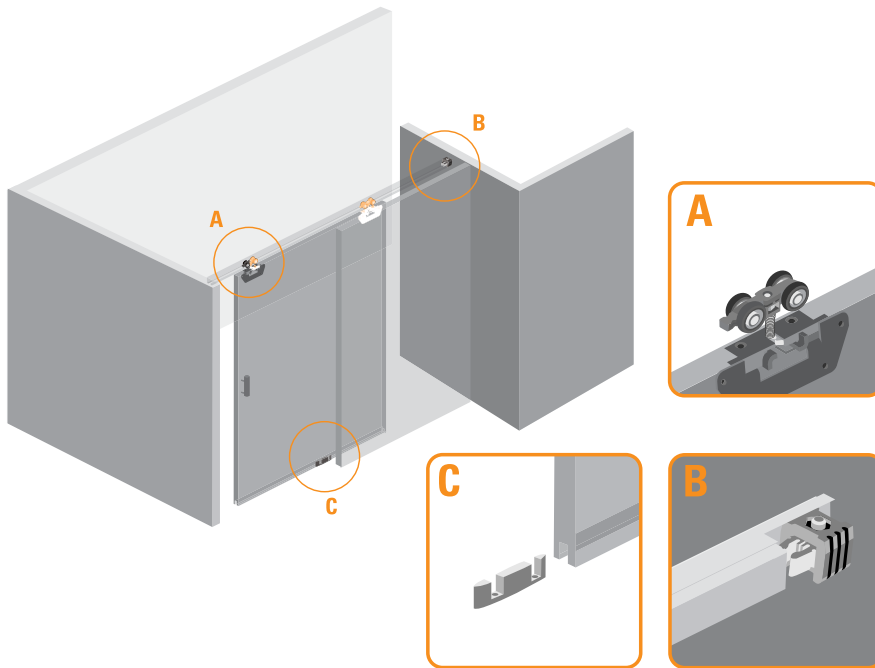

Frontal View

Lateral View

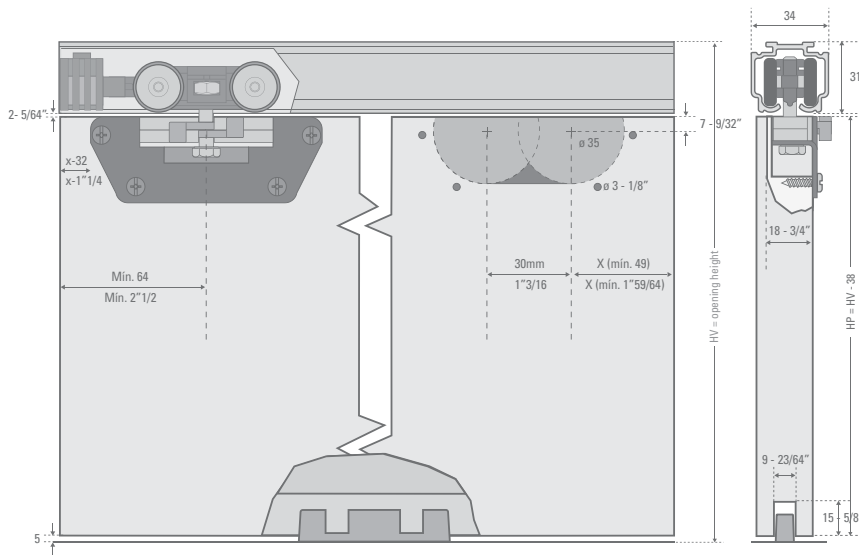

**DN 50 Clip,
set for 2 doors**

PART NUMBER: 10100256051

- A** 4 Carriers DN 50
- B** 4 Mounting plate Brackets
- C** 4 Stoppers with retention device
- D** 2 Floor guide GP-12
- E** Screws

MASTER PACK: 4 sets
MASTER PACK SIZE: 8"25/32 x 7"13/32 x 7"11/64

ALL DIMENSIONS ARE IN MM., CM., KG. USA DIMENSIONS ARE APPROXIMATE

(*) Product tested using ANSI-BHMA protocol. For more information see the glossary of terms

info@ducasseeusa.com | www.ducasseeindustrial.com