

SÉRIE 30145300  
 FEUILLE D'INSTALLATION  
 30145300 SERIES  
 INSTALLATION SHEET

1. Installation

1. Appuyer et coller le ruban DEL sur le profilé-insert dissipateur de chaleur (suivre les guides 10 mm). Acceptera un ruban DEL 10 mm de large maximum.\*

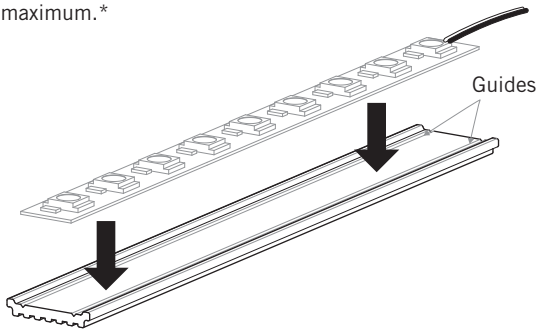

2. Glisser l'insert à l'intérieur de la lentille.

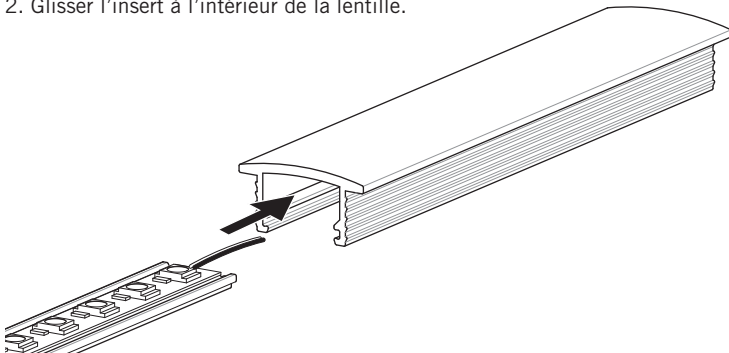

1. Installation

1. Press and glue the LED Strip Tape onto the heatsink insert profile (follow 10 mm guides). Will accept a 10 mm wide strip maximum.\*

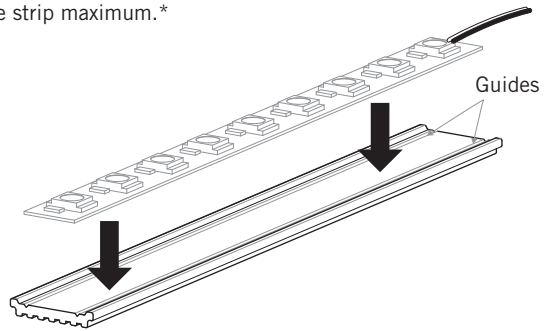

2. Slide the insert into the lens.

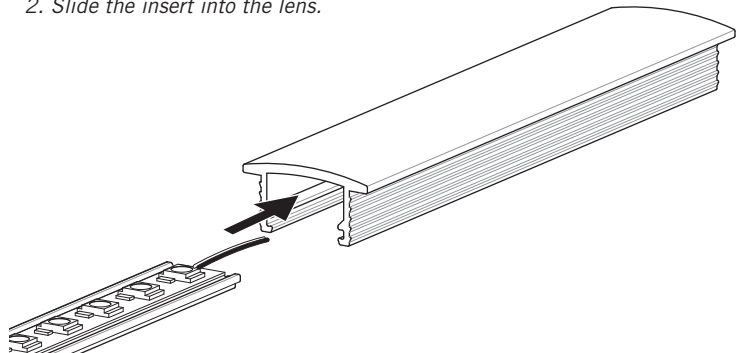

Safe, Fast and Easy to install with the ELED POWER  
 Installation simple et rapide avec le système de connexion  
 ELED POWER



## 1. Installation

3. Mettre le luminaire en place.

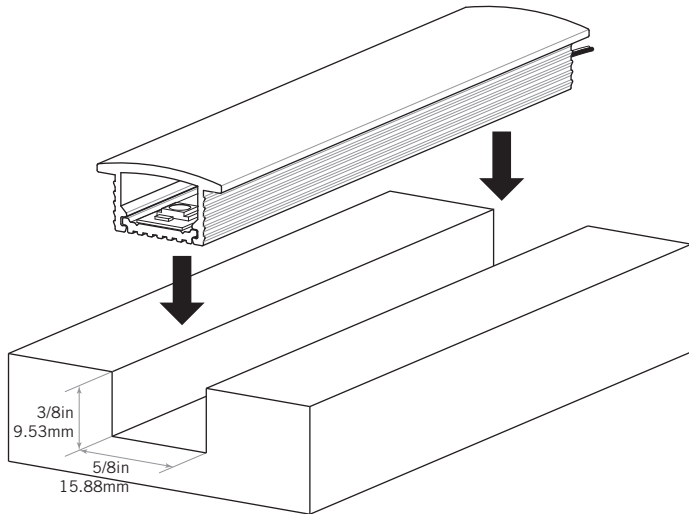

## 1. Installation

3. Insert the lighting fixture in place.

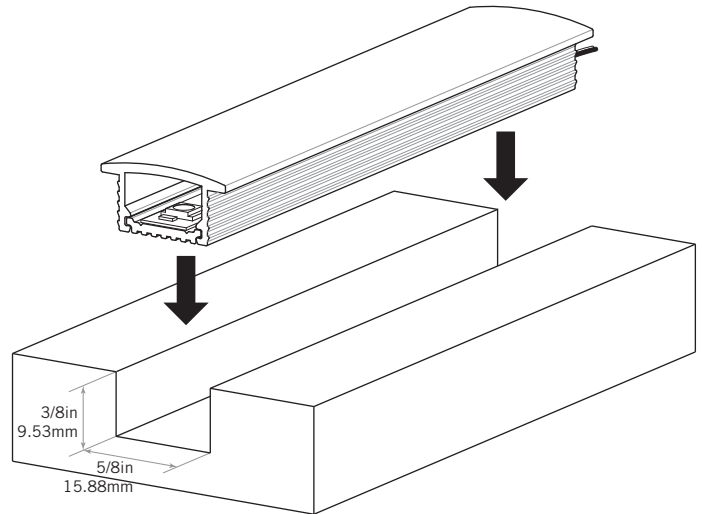

### Mise en garde

1. Utiliser seulement des composantes Certifiées Classe 2 n'excédant pas 30VCC ou 15VAC lors d'une installation dans un endroit mouillé ou 60VCC ou 42.4V ca maximum lors d'une installation dans un endroit sec ou humide.
2. Ne pas dépasser 5 ampères pour respecter les normes classe 2.

CLASSE  
2

100W  
MAX

4 AMP MAX  
↓ 24V

5 AMP MAX  
↓ 12V

\* Les rubans DEL sont vendus séparément.



### Warning

1. Use only Class 2 rated components not exceeding 30VDC or 15VAC when installing the outline lighting in wet locations or 60VDC or 42.4V peak ac when installing the outline lighting in a dry or damp location.
2. Do not go over 5 amps to match class 2 requirements.

CLASS  
2

100W  
MAX

4 AMP MAX  
↓ 24V

5 AMP MAX  
↓ 12V

\* The LED strips are sold separately.