

# ZIPBOLT™ UT-ANGLED RAIL BOLT

## INSTALLATION INSTRUCTIONS MODEL#11.550

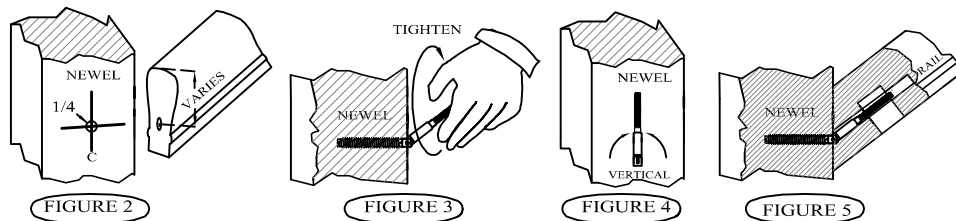
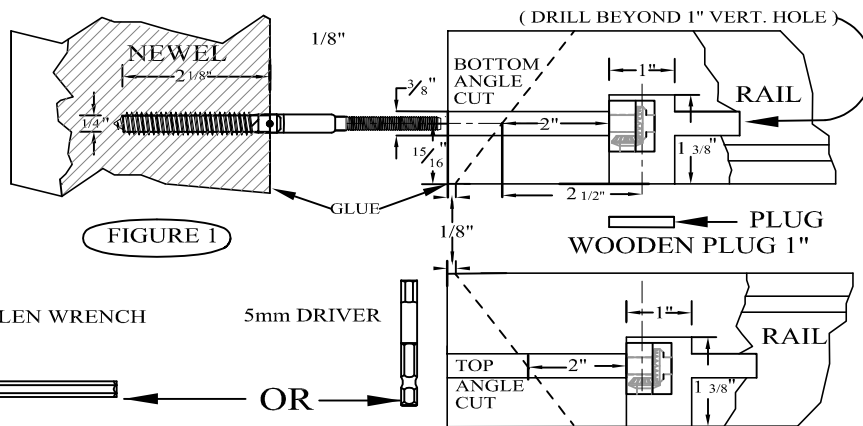
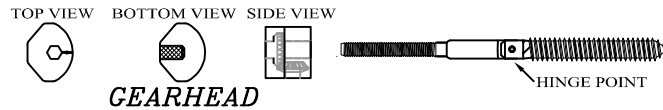

- CUT RAIL 90 DEGREE SQUARE. THEN MARK PROPER ANGLE ON RAILING 1/8" IN FROM END OF 90 DEGREE CUT. (FIG 1)
- MARK CENTER OF RAIL ON 90 DEGREE CUT, UP 15/16" FROM BOTTOM OF RAIL.(FIG. 1)
- DRILL A 1" DIA. HOLE IN BOTTOM OF RAIL ON CENTERLINE 2-1/2" FROM WHERE THE ANGLE AND 15/16" DIMENSION INTERSECT. HOLE SHOULD BE 1-3/8" DEEP.
- DRILL A 3/8" DIA. HOLE IN END OF RAIL. HOLE SHOULD BE 3" - 3-1/2" DEEP DRILLING PAST 1" HOLE. (FIG. 1) IT IS VERY IMPORTANT THAT THE 3/8" HOLE IS DRILLED BEFORE CUTTING THE ANGLE ON THE RAIL.
- MEASURE 1/8" IN FROM END OF 90 DEGREE CUT IN RAIL . MARK TO THE CORRECT PITCH AND START THE CUT AT THAT POINT. (FIG. 1)
- MEASURE DISTANCE FROM TOP OF RAIL TO CENTER OF 3/8" HOLD ON PITCH CUT. (FIG.2)
- MARK NEWEL IN CENTER AND AT PROPER HEIGHT TO ACHIEVE RAIL HEIGHT. (FIG. 2)
- DRILL 1/4" PILOT HOLE 2-1/8" DEEP. (FIG.2)
- INSTALL RAIL BOLT IN POST WITH 2-7/8" OF BOLT PROTRUDING. (FIG 3) VERIFYING THAT THE BOLT ENDS IN THE VERTICAL POSITION. (FIG.4)
- SLIDE RAIL ON TO BOLT AND "DRY FIT" TO BE SURE OF PROPER ANGLE AND FIT. IF ANOTHER CUT IS NEEDED TAKE THE LEAST AMOUNT OFF TO CORRECT CUT. (FIG 5) THE 3/8" DEEP HOLE THAT WAS DRILLED HAS ALLOWED ENOUGH ROOM FOR YOU TO MAKE THIS ADJUSTMENT.

WHEN PROPER FIT IS COMPLETE, GLUE, INSERT GEAR HEAD AND TIGHTEN INTO PLACE WITH 5MM DRIVER OR ALLEN WRENCH. GLUE AND INSERT A WOODEN 1" DIA PLUG. SAND FLUSH WITH BOTTOM OF RAIL.

**SUPPORTING TEMPLATE ON OTHER SIDE. CAN BE USED IN MOST APPLICATIONS**