

DN 80 VD

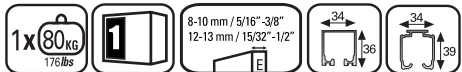

Verre Glass
 Rail de chariot U21, plat Carrier Track U21 Flat
 Rail de chariot U21 Carrier Track U21

H1min= HV - 114mm
 H1max= HV - 103 mm
 AP= AV/2 + 20mm.

H1min= HV - 114mm
 H1max= HV - 100 mm
 AP= AV/2 + 20mm.

H1min= HV - 111mm
 H1max= HV - 100 mm
 AP= AV/2 + 20mm.

H1min= HV - 111mm
 H1max= HV - 97 mm
 AP= AV/2 + 20mm.

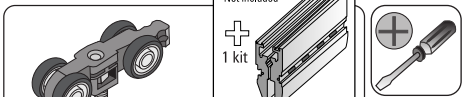
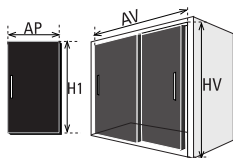

Non inclus Not included
 + 1 kit

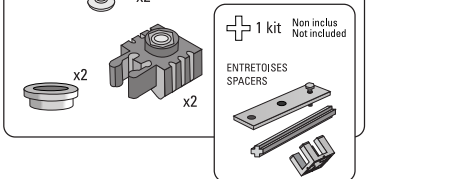

Non inclus Not included
 + 1 kit
 ENTRETOISES SPACERS

mm	Pouces en décimales	Fraction approx.	mm	Pouces en décimales	Fraction approx.
mm	Decimal inches	Approx Fraction	mm	Decimal inches	Approx Fraction
1	0.0394	3/64	6	0.2362	15/64
2	0.0787	5/64	7	0.2756	9/32
3	0.1181	1/8	8	0.3150	5/16
4	0.1575	5/32	9	0.3543	23/64
5	0.1969	13/64	10	0.3937	25/64

Toutes les mesures sont exprimées en millimètres

All measurements in millimeters

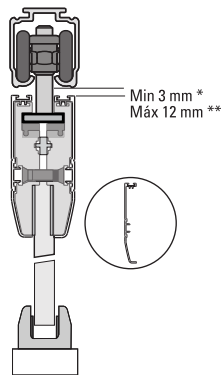
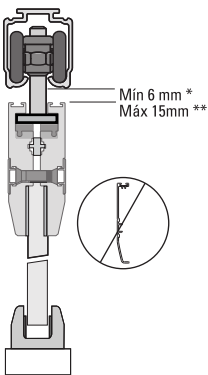

* Réglage avec H1 max.
 * Regulation with H1max.

** Réglage avec H1 min.
 ** Regulation with H1min

1

1.1

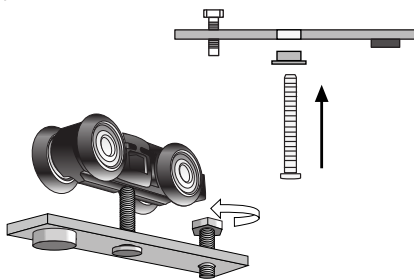

1.2

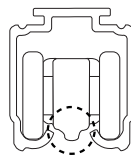
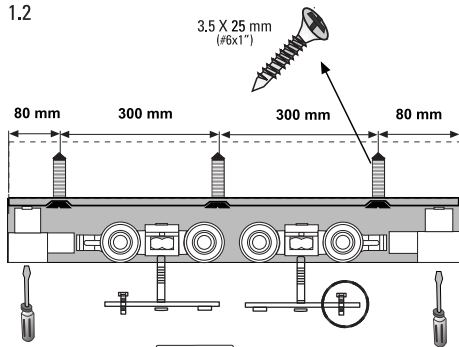

2

2.1

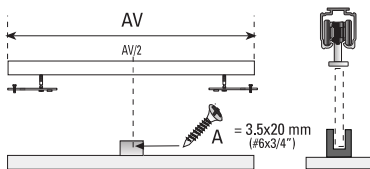
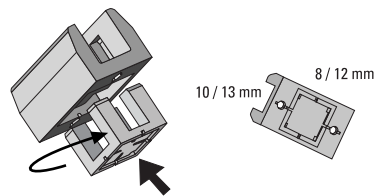

2.2

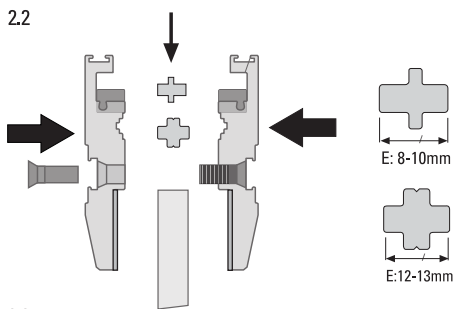

2.3

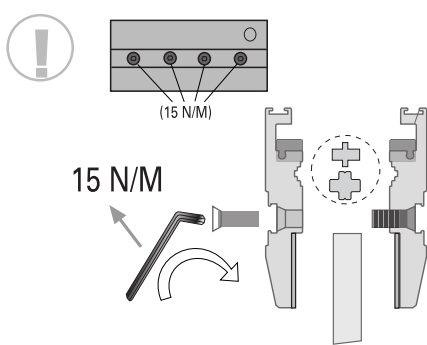

3

3.1

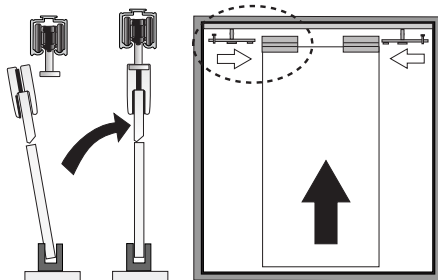

3.2

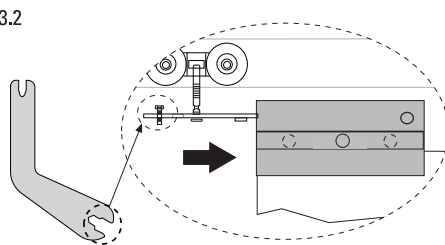

4

4.1

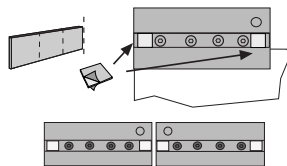

4.2

OPTION 1

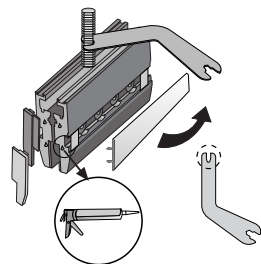

OPTION 2

Bordure pour chariots pour porte en verre - non inclus
Fascia for Glass carriers - not included

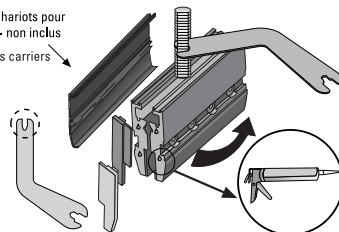

* ACCESSOIRES / ACCESSORIES

Support en montage mural, large
Wide Wall Mounting Bracket
E= $\leq 50\text{mm}$

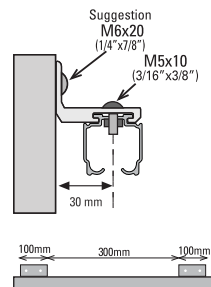

Butoir pour porte en verre
Glass Stopper

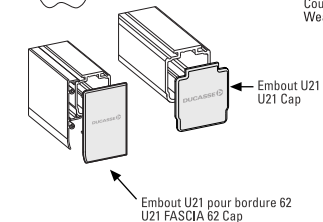
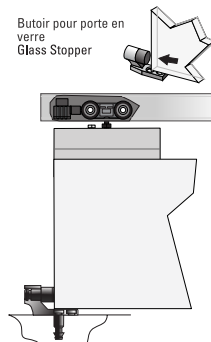

Rail de chariot large, verre statique
Static glass wide carrier track
E = 8mm - 13mm

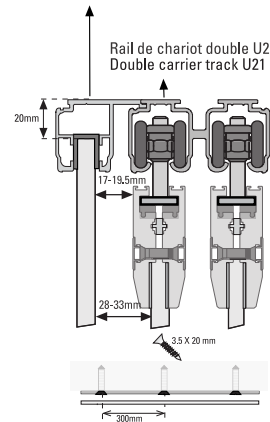

Rail de chariot, verre à faible statique
Low static glass carrier track
E = 8mm - 13mm

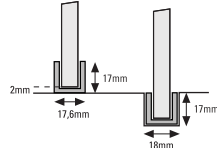

Coupe-froid
Weatherstrippings

