

CROWDERFRAME 'C' SLIDING POCKET DOOR KIT

WITH C-411 SPINWHEEL HANGER



CROWDERFRAMES ARE THE ANSWER WHERE SPACE IS LIMITED OR WHERE THE SWINGING OF A HINGED DOOR IS UNDESIRABLE OR INCONVENIENT. ENJOY THE BENEFITS OF HIDING THE DOOR IN A WALL FOR A CLEAN AND SPACIOUS LOOK! CAN BE INSTALLED IN ONE CONTINUOUS PIECE FOR SINGLE OR DOUBLE DOORS.

NEW!

CYCLE TESTED PRECISION BALL BEARINGS. SMOOTH AND SILENT SLIDING DOORS!

ROLL FORMED STEEL UPRIGHTS FOR LESS DEFLECTION AND EASY TO SCREW INTO FOR DRYWALL FASTENING!

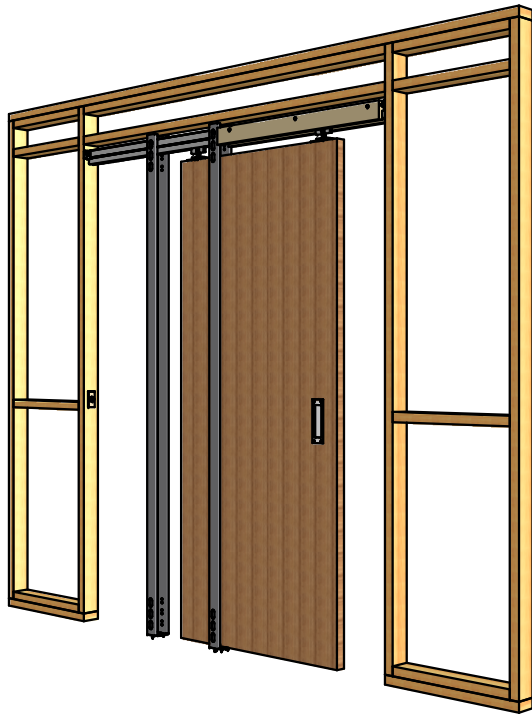

TOOLS REQUIRED

- 1" DRYWALL SCREWS ONLY (SUPPLIED)
- DRILL OR IMPACT DRIVER
- SAW (IF REQUIRED)
- TAPE MEASURE
- PENCIL
- LEVEL
- CHALK LINE
- STEP/SMALL LADDER
- SQUARE
- 3/8" HEX DRIVER BIT
- ROBINSON DRIVER BIT OR SCREWDRIVER
- 3/8" DRILL BIT
- 1/8" DRILL BIT
- 1/2" WRENCH

CHART A

ROUGH OPENING SIZE







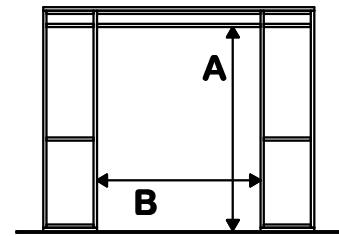





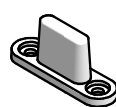

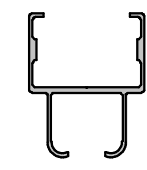
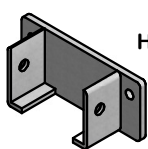
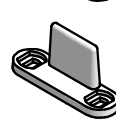

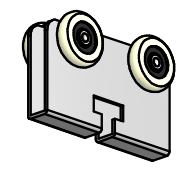
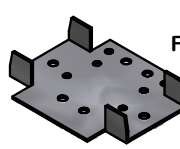
ROUGH OPENING HEIGHT (A) FOR DOORS UP TO 7' MUST BE AT LEAST 90-1/2" (2399 mm). ROUGH OPENING HEIGHT (A) FOR DOORS UP TO 8' MUST BE AT LEAST 102-1/2" (2604 mm).

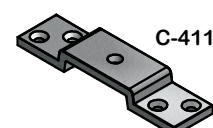
DOOR WIDTH	ROUGH OPENING WIDTH (B)
2'-0" (610 mm)	48-3/8" (1229 mm)
2'-2" (661 mm)	52-3/8" (1330 mm)
2'-4" (711 mm)	56-3/8" (1432 mm)
2'-6" (762 mm)	60-3/8" (1534 mm)
2'-8" (813 mm)	64-3/8" (1635 mm)
2'-10" (864 mm)	68-3/8" (1737 mm)
3'-0" (915 mm)	72-3/8" (1838 mm)

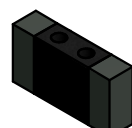
TO DETERMINE ROUGH OPENING WIDTH FOR NON-STANDARD DOORS, MULTIPLY DOOR WIDTH BY TWO (2) AND ADD 3/8".



PARTS LIST (FOR STANDARD TYPE C POCKET DOOR KIT)

-  STEEL UPRIGHTS (4)
-  5/16" HEX NUT (4)
-  1" X 3" X 72" MDF BOARD (1)
-  C-1201 CENTRE GUIDE FOR 1-3/8" DOOR (2)
-  5/16" EXTERNAL TOOTH LOCK WASHER (4)
-  TYPE 'C' EXTRUDED ALUMINUM HEADER (1)
-  HEADER BRACKET (2)
-  C-1202 OFFSET GUIDE FOR 1-3/4" DOOR (2)
-  #10 X 2" FLATHEAD SCREWS (8)
-  C-411 HANGER (2)
-  FOOT BRACKET (2)
-  C-99 RUBBER DOME BUMPER (1)
-  #10 X 1-1/2" SELF DRILLING SCREWS (8)
-  C-411 TOP PLATE (2)
-  C-411 T-BOLT (2)
-  C-100 DOOR STOP (1)
-  #10 X 1-1/4" SCREWS (5)
-  C-411 SPINWHEEL (2)
-  1/4" - #14 X 3/4" HEX TEK SCREW (8)
-  #8 X 3/4" SCREWS (10)
-  3/16" SPACER WASHERS (6)
-  1" FINE THREAD DRYWALL SCREWS (25)



K.N. CROWDER MFG. INC.
 1220 BURLOAK DRIVE
 BURLINGTON, ONTARIO, CANADA, L7L 6B3
 TELEPHONE: 905-315-9788 - FAX: 905-315-8090
 TOLL FREE FAX: 1-800-567-0123

K.N. CROWDER INC.
 210 EIGHTH STREET SOUTH
 LEWISTON, NEW YORK, U.S.A. 14092
 TOLL FREE TELEPHONE: 1-866-999-1KNC (1562)
 TOLL FREE FAX: 1-800-567-0123

WEBSITE: www.kncrowder.com --- E-MAIL: customerservice@kncrowder.com

STEP 1

CUT ALUMINUM HEADER TO CORRECT SIZE IF REQUIRED. (STANDARD LENGTH IS 71-7/8") TO DETERMINE HEADER LENGTH TAKE 2 X THE DOOR WIDTH AND SUBTRACT 1/8".
EXAMPLE: DOOR WIDTH IS 36" THEREFORE $36" \times 2 = 72" - 1/8" = 71-7/8"$.

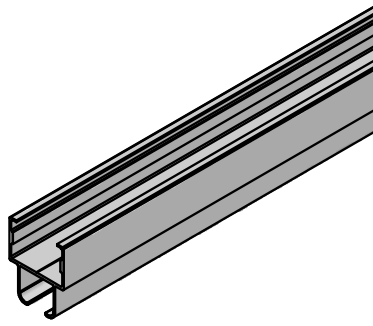

STEP 2

REFER TO CHART B FOR HEADER BRACKET LOCATION. MARK A LINE ON WALL STUD FOR TOP OF HEADER BRACKET.

HEADER BRACKET HEIGHT

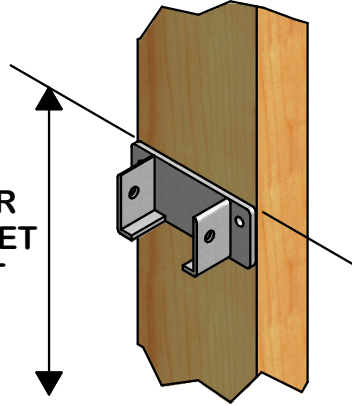

STEP 3

SECURE ONE HEADER BRACKET IN PLACE WITH #10 X 1-1/4" SCREWS (2) ON THE LINE AS MARKED IN STEP 2.

CHART B

HEADER BRACKET HEIGHT

SET TOP OF BRACKET AT FOLLOWING DIMENSIONS. (1/2" CLEARANCE UNDER DOOR INCLUDED)

DOOR HEIGHT	BRACKET HEIGHT*
6'-8" (2032 mm)	85-1/16" (2161 mm)
6'-10" (2083 mm)	87-1/16" (2211 mm)
7'-0" (2134 mm)	89-1/16" (2262 mm)
8'-0" (2438 mm)	101-1/16" (2567 mm)

*FOR THICK FLOOR FINISHES, IT MAY BE NECESSARY TO SHIM FLOOR BRACKETS AND ADJUST HEADER BRACKET HEIGHT ACCORDINGLY.

CHART C

FLOOR BRACKET LOCATION

DOOR WIDTH	DIMENSION C	DIMENSION D*
2'-0" (610 mm)	12-7/16" (316 mm)	24-7/16" (621 mm)
2'-2" (661 mm)	13-7/16" (341 mm)	26-7/16" (672 mm)
2'-4" (711 mm)	14-7/16" (367 mm)	28-7/16" (722 mm)
2'-6" (762 mm)	16-7/16" (418 mm)	30-7/16" (773 mm)
2'-8" (813 mm)	16-7/16" (418 mm)	32-7/16" (824 mm)
2'-10" (864 mm)	18-7/16" (468 mm)	34-7/16" (875 mm)
3'-0" (915 mm)	20-7/16" (519 mm)	36-7/16" (926 mm)

* ASSUME 3/4" JAMB TRIM

STEP 4

PLACE HANGERS INTO HEADER TRACK WITH T-SLOT FACING SAME SIDE OF OPENING (FIGURE 1). PUT ONE END OF HEADER INTO THE HEADER BRACKET INSTALLED IN STEP 3. USING A LEVEL TO CHECK HEADER (FIGURE 2), PLACE OTHER BRACKET ON OPPOSITE END AND SECURE TO STUD WITH #10 X 1-1/4" SCREWS (2) (FIGURE 3).

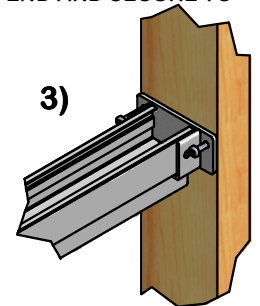
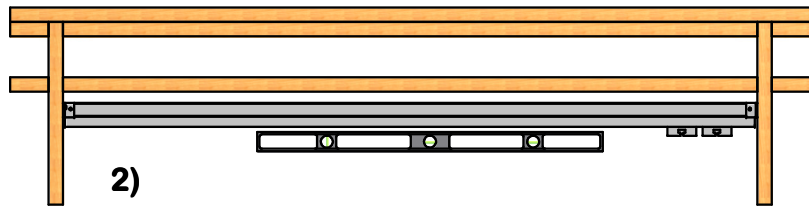
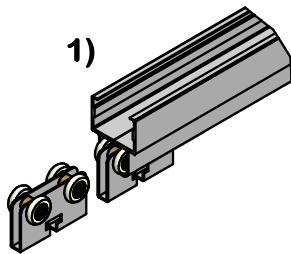

STEP 5

SECURE HEADER TO HEADER BRACKETS WITH 1/4" #14 X 3/4" HEX TEK SCREWS (4).
NOTE: IMPACT DRIVER IS IDEAL FOR THIS STEP OR PRE-DRILL WITH 9/64" BIT IF DESIRED.

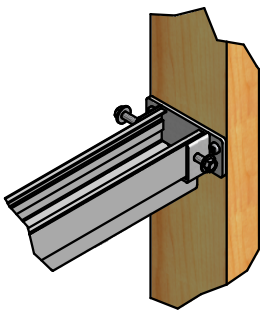

STEP 7

LOCATE AND MARK LINES PERPENDICULAR TO THE CHALK LINES OF THE WALL FOR FOOT BRACKET LOCATION. REFER TO CHART "C" FOR THE MEASUREMENTS. SEE ILLUSTRATIONS.

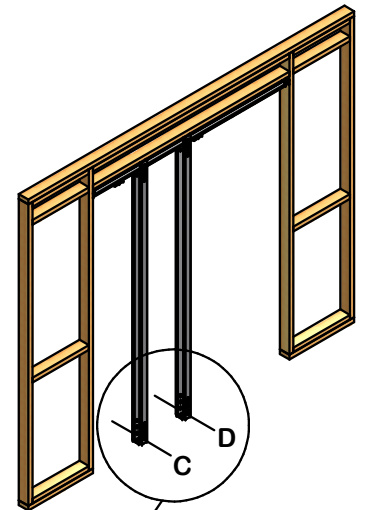

STEP 8

POSITION FOOT BRACKETS AT LINE DETERMINED IN PREVIOUS STEP. CENTRE BETWEEN WALL LINES MARKED IN STEP 6. SEE ILLUSTRATION FOR HOLE ORIENTATION. SECURE TO FLOOR WITH #8 X 3/4" SCREWS (4).

STEP 6

PLACE CHALK LINE AGAINST THE BOTTOM STUDS OF THE WALL TO MARK THE LINE OF THE OPENING ON BOTH SIDES.

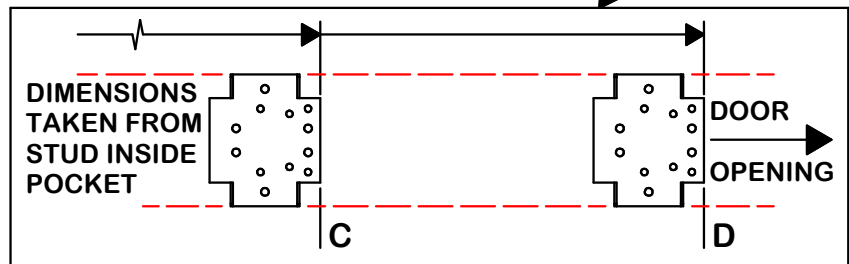
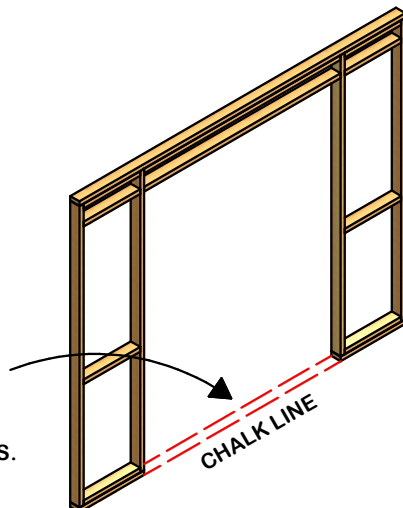

STEP 9

LOCATE AND SECURE C-1201 CENTRE GUIDES OR C-1202 OFFSET GUIDES ON FOOT BRACKET CLOSEST TO DOOR OPENING WITH #8 X 3/4" SCREWS (4). IF AN OPTIONAL GUIDE SYSTEM HAS BEEN PURCHASED INSTALL IN PLACE OF STANDARD GUIDES. (SEE BACK PAGE)

USE C-1201 GUIDES FOR 1-3/8" DOOR

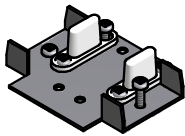

OR

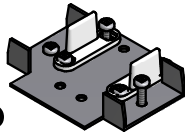

USE C-1202 GUIDES FOR 1-3/4" DOOR

STEP 10

POSITION STEEL UPRIGHTS ON FOOT BRACKET WITH LARGE OVAL CLEARANCE HOLES FACING OUT. THE UPRIGHTS ARE PUNCHED SYMMETRICALLY AND EITHER END CAN BE UP (OR DOWN). THE ROLLED SEAM ON THE SIDE WALL OF THE UPRIGHT SHOULD FACE THE BACK OF THE POCKET- OTHERWISE IT WILL BE DIFFICULT TO SCREW OPENING TRIM TO THE UPRIGHT. PLUMB THE UPRIGHTS VERTICALLY AND SECURE TO HEADER WITH 1/4" - #14 X 3/4" HEX TEK SCREWS (4) AND 5/16" EXTERNAL TOOTH LOCK WASHERS (4).

NOTE: IMPACT DRIVER IS IDEAL FOR THIS STEP OR PRE-DRILL WITH 9/64" BIT IF DESIRED.

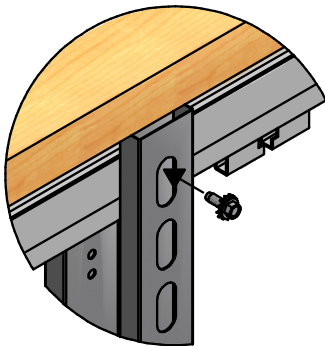
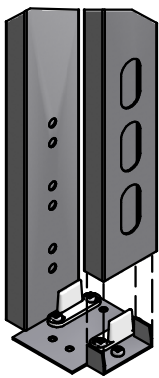

STEP 11

CUT THE SUPPLIED 1" X 3" MDF BOARD TO THE APPROPRIATE LENGTH (DOOR WIDTH LESS 3/4") AND FASTEN TO HEADER OVER OPENING SECTION WITH #10 X 1-1/2" S.D.S. SCREWS (3 PER SIDE). PRE-DRILL HOLES ON BOARD WITH 13/64" DRILL BIT, 5/8" DOWN FROM THE TOP EDGE OF BOARD.

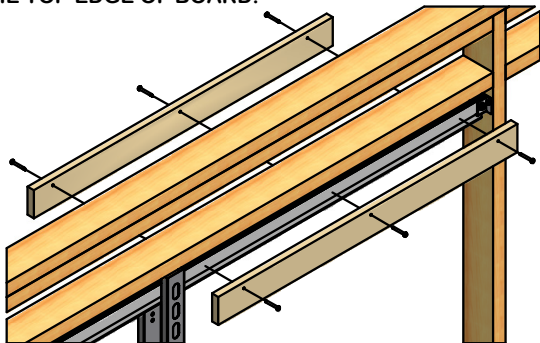

STEP 12

A) LOCATE CLEARANCE HOLE FOR HANGER STUD 3-1/2" FROM EACH EDGE OF DOOR. DRILL WITH 3/8" BIT AT LEAST 2" DEEP.

B) CENTER TOP PLATE OVER HOLE, MARK SCREW HOLE LOCATIONS AND PRE-DRILL WITH 1/8" BIT AT LEAST 1-1/2" DEEP.

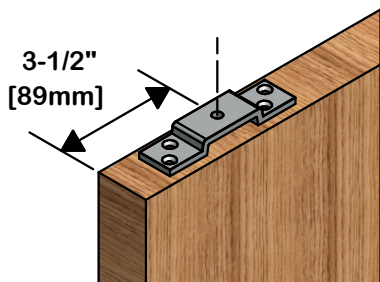

STEP 13

PREPARE TOP PLATE ASSEMBLIES (2 SETS) AS FOLLOWS: TOP PLATE (1) WITH T-BOLT (1), 5/16" HEX NUTS (2) AND SPIN-WHEEL (1).

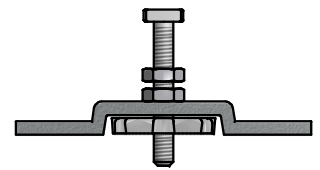

STEP 14

MOUNT TOP PLATE ASSEMBLIES ON DOOR AND SECURE WITH #10 X 2" FLATHEAD SCREWS (8).

STEP 15

INSTALL OPTIONAL PRODUCTS IF PURCHASED SUCH AS GUIDE CHANNELS, CUP PULLS, DOOR LOCKS, ETC. INDIVIDUAL INSTRUCTIONS ARE PROVIDED WITH THE RESPECTIVE PRODUCT.

STEP 16

PLACE BACK END OF DOOR INTO POCKET OPENING AND PLACE REAR T-BOLT INTO HANGER SLOT. REPEAT FOR FRONT HANGER.

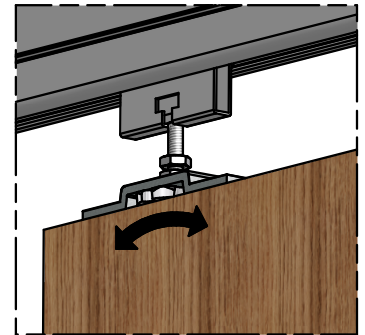
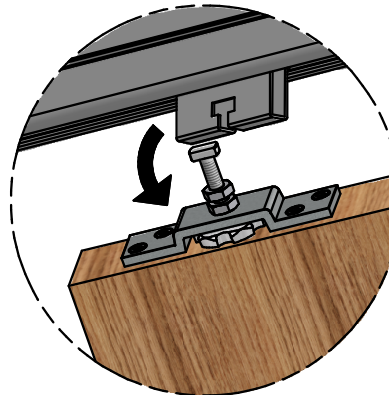

STEP 17

ADJUST DOOR HEIGHT AND PLUMB VIA SPINWHEEL. LOCK ADJUSTMENT BY TIGHTENING HEX NUT AGAINST TOP PLATE. PREVENT UNINTENTIONAL DISCONNECTION OF DOOR FROM HANGER BY LOCKING SECOND HEX NUT AGAINST UNDERSIDE OF HANGER.

STEP 18

INSTALL C-99 RUBBER DOME BUMPER ON FRAME STUD AT BACK OF POCKET. MOUNT AT MID HEIGHT OF DOOR WITH #10 X 1-1/4" SCREW (1). WHEN DOOR IS OPENED IT WILL BE CUSHIONED BY BUMPER. SHIM WITH 3/16" FENDER WASHERS (1-6) TO SUIT THE TRIM BEING USED AT POCKET OPENING SO THAT DOOR EDGE IS FLUSH WITH TRIM WHEN DOOR IS FULLY OPEN.

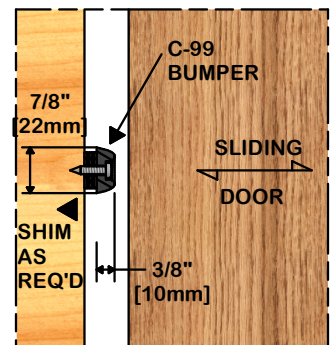

STEP 19

THE C-100 BUMPER MAY BE USED TO STOP THE DOOR BEFORE STRIKING JAMB WHEN CLOSING. POSITION THE STOP IN THE TRACK AND SECURE WITH #10 X 1-1/2" S.D.S SCREWS (2).

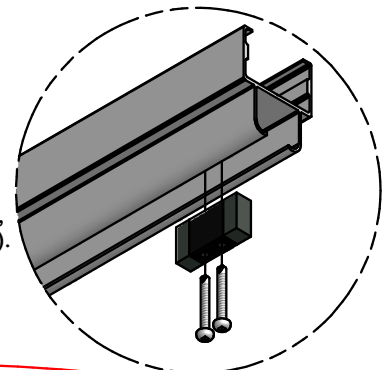

STEP 20

FINISH PROJECT WITH FINISHING REQUIREMENTS SUCH AS DRYWALL, TRIM, DOOR JAMS, ETC (BY OTHERS). SUGGESTION: ONE SIDE OF FASCIA TRIM SHOULD BE MADE 'EASILY' REMOVABLE FOR FUTURE ACCESS TO ADJUSTMENTS.

CAUTION:

USE 1" DRYWALL SCREWS ONLY (PROVIDED) WHEN SECURING DRYWALL TO UPRIGHTS. LONGER SCREWS WILL PENETRATE INSIDE FACE OF STEEL UPRIGHT AND DAMAGE DOOR. FASTEN DRYWALL TO BOTTOM OF STEEL UPRIGHT FIRST WORKING UP TO THE TOP.

HOW IT ALL COMES TOGETHER

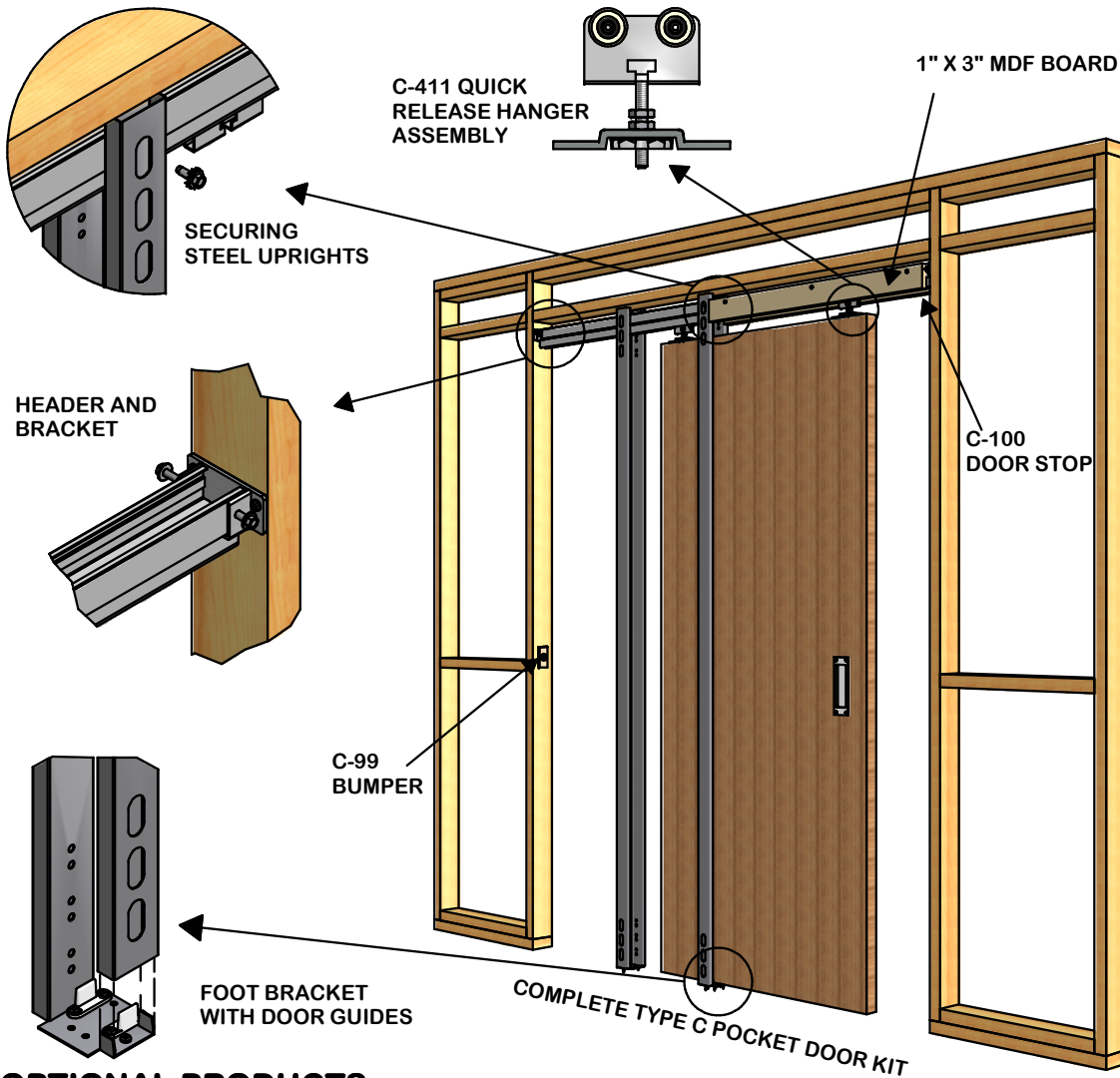

TYPE C POCKET DOOR KIT SECTION VIEW

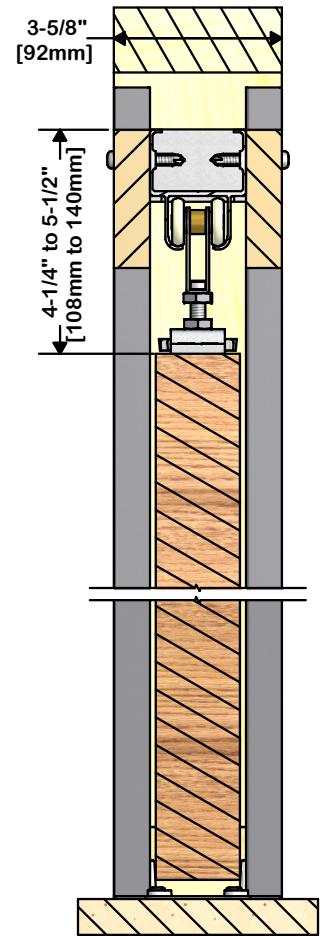

OPTIONAL PRODUCTS

POCKET DOOR KITS ARE AVAILABLE FOR DOUBLE DOOR APPLICATIONS AND NON-STANDARD DOOR SIZES SUCH AS:

- 8'-0" HIGH DOORS*
- 3'-2" WIDE DOORS**
- 3'-4" WIDE DOORS**
- 3'-6" WIDE DOORS**
- 4'-0" WIDE DOORS**

-CONTACT US FOR OTHER SPECIAL SIZES AND APPLICATIONS.

-SHIM KIT FOR 2" X 6" WALL CONSTRUCTION AVAILABLE.

* STANDARD STEEL UPRIGHTS ARE REPLACED BY LONGER ONES TO ACCOMMODATE UP TO 8'-0" HIGH DOORS.

**FOR DOORS WIDER THAN 3'-0", SIX (6) UPRIGHTS ARE PROVIDED TO SUPPORT THE LONGER HEADER.

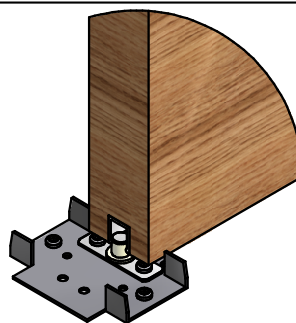

C-200 GUIDE WITH C-201 GUIDE CHANNEL

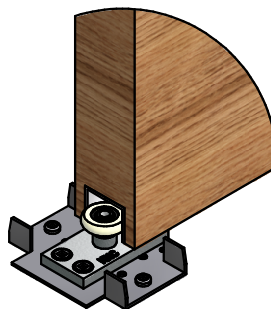

C-913 GUIDE WITH C-914 GUIDE CHANNEL



C-35 DOOR LOCK



C-90L DOOR LOCK



SEE MORE @ KNCROWDER.COM