

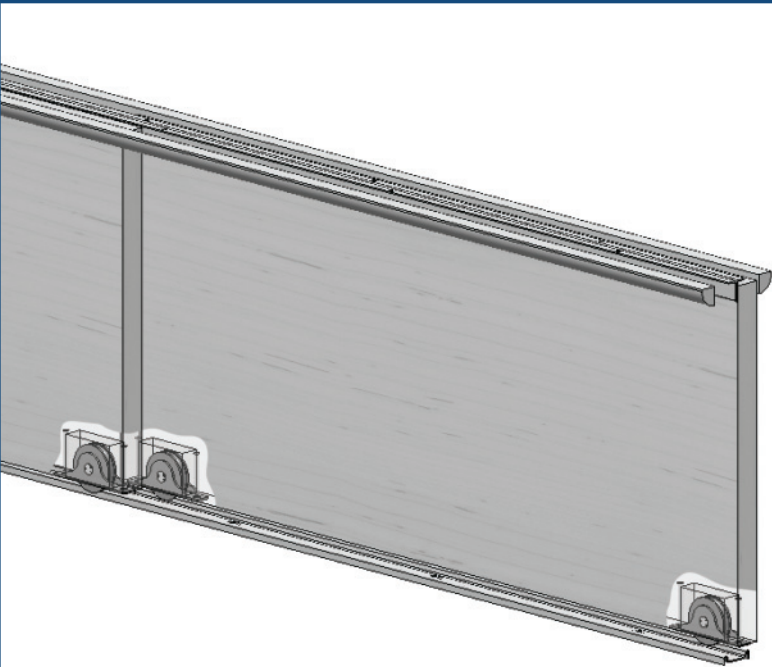

# Metal Tracks and Sheaves for Sliding Wood Doors

## SLIDING DOOR TRACK

- For sliding wood doors
- 6' to 12' lengths available
- Cut to fit



### Complete Assembly Example

(469 Double Track + 430 Ball Bearing Round Groove Sheave  
+ 953 Upper T Guide for Ball Bearing Track)

### Applications

Provides smooth track system for sliding wood doors to move back and forth with ease. Ideal for larger wood door installations.

**Mounting:** Recessed or Surface

**Material:** Steel, Zinc or Bronze

### Finishes:

Plain Finish Wrought Steel (STL),  
Stainless Steel (SS), Steel (STL), Zinc (ZC):  
Long-lasting, corrosion resistant finish

### Features:

- Installs quickly and easily with nails or glue
- Allows door to slide easily and quietly
- Can be mounted on surface or recessed
- Upper T Guide separates sliding doors at top
- Components can be easily cut to fit any opening up to 12 feet
- Variety of sheaves available to accommodate various installation needs
- Made in the USA
- Available from open stock

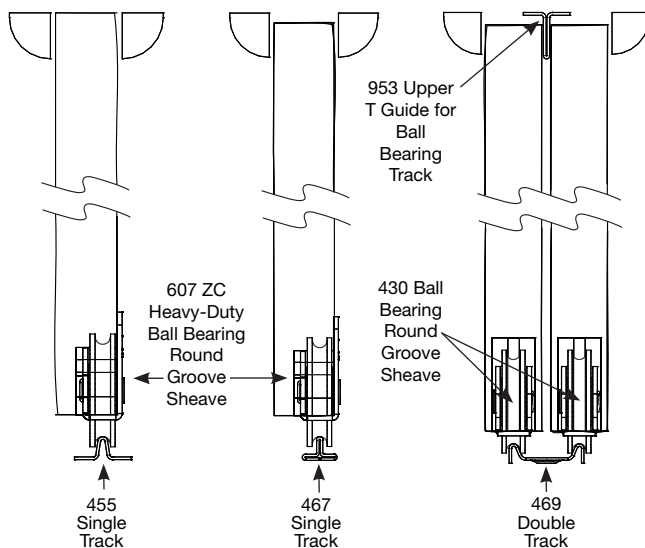

### Cross Section Examples

## Metal Tracks



**455  
Single Track**

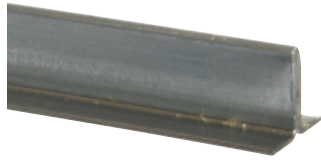

**467  
Single Track**



**469  
Double Track**

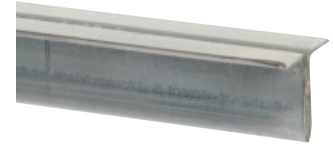

**953  
Upper T Guide  
for Ball Bearing Track**

Standard Pack (1/carton)									
Description	Width	Height	Length	Weight	Plain Finish Wrought Steel	Stainless Steel	Plain Finish Steel	Zinc Plated Steel	Pre-coated Steel
455 STL Single Track (Plain Finish Wrought Steel)	21/32"	5/16"	144"	1.5 lbs.	455 STL 144*	-	-	-	-
455 SS Single Track (Stainless Steel)	21/32"	5/16"	144"	1.5 lbs.	-	455 SS 144*	-	-	-
467 Single Track (Plain Finish Steel)	21/32"	5/16"	144"	1.8 lbs.	-	-	467 STL 144*	-	-
469 Double Track (72")	1"	1/4"	72"	1.3 lbs.	-	-	-	469 ZC 72**	-
469 Double Track (96")	1"	1/4"	96"	1.7 lbs.	-	-	-	469 ZC 96**	-
469 Double Track (144")	1"	1/4"	144"	2.5 lbs.	-	-	-	469 ZC 144**	-
953 Upper T Guide for Ball Bearing Track (Separates sliding doors at top.)	5/8"	5/8"	144"	2.2 lbs.	-	-	-	-	953 ZC 144

\*Includes 1/2" nails. \*\*Includes 1/2" x No. 5 flathead wood screws.

## Sheaves



**400A STL**  
Ball Bearing Sheave Drive Type



**402 STL**  
Ball Bearing Sheave

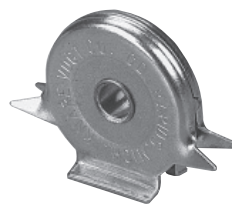

**580 STL**  
Nylon Round Groove Sheave  
(for light doors)



**582 STL**  
Nylon Round Groove Sheave

Enclosed Sheaves									
Description	Packed	Weight (lbs./box)	Case Size (height x width)	Flange Size (length x width)	For KV Track Numbers:				Steel (STL)
					450	455	467	469	
400A Ball Bearing Sheave, Drive Type	100/box	4.63	1-1/4" x 5/16"	1-3/4" x 9/16"	x	x	x	x	400A STL
402 Ball Bearing Sheave	100/box	6.93x	1-1/4" x 5/16"	2-1/4" x 5/16"	x	x	x	x	402 STL
580 Nylon Round Groove Sheave, Drive Type (For light doors.)	100/box	3.93	1-1/4" x 5/16"	1-3/4" x 9/16"	x	x	x	x	580 STL
582 Nylon Round Groove Sheave (For light doors.)	100/box	5.12	1-1/4" x 5/16"	2-1/4" x 5/16"	x	x	x	x	582 STL



**413X BR**  
Bronze Wheel  
(with Brass-look frame)  
on Self Lubricating  
Bearing



**427 STL**  
Ball Bearing Round  
Groove Sheave

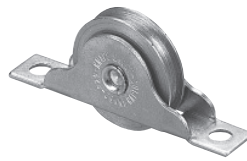

**429 STL**  
Round Groove Sheave



**430 STL**  
Ball Bearing Round  
Groove Sheave



**430 N STL**  
Ball Bearing Sheave  
with Flat Neoprene  
Wheel



**592 STL**  
Nylon Convex Wheel  
(for thin doors)



**594 NYLON** Nylon  
Round Groove Wheel  
(for doors up to  
1-1/8" thick)



**607 ZC**  
Heavy-Duty Ball  
Bearing Round  
Groove Sheave



**620 STL**  
Axle Bearing  
Grooved Steel Roller

Sheaves										
Description	Packed	Weight (lbs./box)	Frame Size (height x width)	Wheel Size	For KV Track Numbers:				Brass-look (BR)	Steel (STL)
					450	455	467	469		
413X Bronze Wheel (with Brass-look frame) on Self Lubricating Bearing	50/box (w/screws)	7.06	2-15/16" x 7/16"	1-3/16" Dia.	x	x	x	x	413X BR	-
427 Ball Bearing Round Groove Sheave	50/box	5.87	2-15/16" x 1/2"	1-3/16" Dia.	x	x	x	x	-	427 STL
429 Round Groove Sheave	100/box	6.50	2-1/4" x 3/8"	1" Dia.	x	x	x	x	-	429 STL
430 Ball Bearing Round Groove Sheave	50/box	7.37	2-3/4" x 1/2"	1-3/8" Dia.	x	x	x	x	-	430 STL
430 N Ball Bearing Sheave with Flat Neoprene Wheel (use WITHOUT track)	50/box	6.12	2-3/4" x 1/2"	1-3/8" Dia.	x	x	x	x	-	430 N STL
592 Nylon Convex Wheel (for thin doors)	100/box	2.80	9/32" x 2-1/4"	1-3/16" Dia.		x*			-	592 STL
594 Nylon Round Groove Wheel (for doors up to 1-1/8" thick)	50/box	3.37	2-15/16" x 1/2"	1-3/16" Dia.	x	x	x	x	-	594 NYLON
607 Heavy-Duty Ball Bearing Round Groove Sheave (with side fastening plate)	50/box	9.12	2-5/16" x 1-5/16"	1-3/8" Dia.	x	x	x	x	-	607 ZC
620 Axle Bearing Grooved Steel Roller	100/box	3.75	7/16" x 1-7/8"	11/16" H x 9/32" W	x	x	x	x	-	620 STL

\* For use with inverted KV Track Number 455.

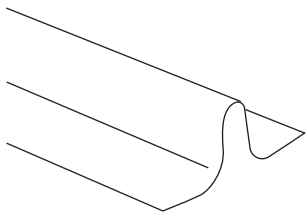

**455**  
Single Track

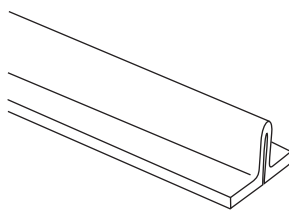

**467**  
Single Track

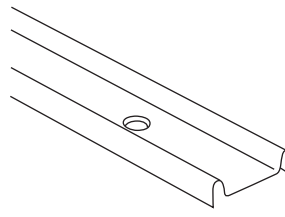

**469**  
Double Track

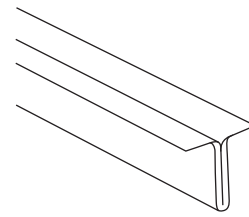

**953**  
Upper T Guide  
for Ball Bearing Track

## 1. PRODUCT NAME

**Metal Tracks and Sheaves for Sliding Wood Doors.** Provides a smooth track system for sliding wood doors to move back and forth with ease.

## 2. MANUFACTURER

Knapé & Vogt  
2700 Oak Industrial Dr. NE, Grand Rapids, MI USA 49505-6026  
(616) 459-3311 | www.kv.com

## 3. PRODUCT DESCRIPTION

**Basic Use:** Metal Tracks and Sheaves for Sliding Wood Doors provide a smooth track system for sliding wood doors to move back and forth with ease. A variety of sheaves provide wheel base to support wood door while gliding smoothly along metal track.

### Composition and Materials:

- 455 STL: Wrought Steel
- 455 SS: Stainless Steel
- 467: Steel
- 469: Zinc
- 953: Pre-coated Steel

### Sizes:

- 455, 467: 21/32" wide x 5/16" high x selected length
- 469: 1" wide x 1/4" high x selected length
- 953: 5/8" wide x 5/8" high x selected length

**Lengths:** 72", 96, 144" (some lengths not available in all tracks.)

**Finishes:** Plain Finish Wrought Steel, Stainless Steel, Steel, Zinc, Precoated Steel.

## 4. TECHNICAL DATA

**Applicable Standards:** Metal Tracks and Sheaves for Sliding Wood Doors are tested to meet or exceed ANSI performance standards as established by BHMA in the Knapé & Vogt™ (KV) recommended application.

Results were obtained by laboratory testing in accordance with ANSI/ BHMA A156.9-2003 performance standard. Actual use conditions will typically result in lower load capacity than laboratory conditions.

Representative testing in a fully configured application is the only way to assure proper performance, durability, and safety.

### Environmental Considerations:

**Environment:** Excessive humidity, salts, or other chemical agents can corrode the finish and attack metal or plastic components.

**Fastening:** Inadequate or incorrect fasteners can result in the track or sheave pulling loose and causing damage.

**Alignment:** Improper track/sheave alignment can result in a sliding door system that is ineffective and unsafe.

1. Lay guide and track in recessed grooves or on surface.
2. Attach with small nails or glue.
3. Height of wood door should be 1-1/4" (3.75mm) shorter than distance between top of guide and bottom of track.
4. Place top of door in guide and swing bottom of door into track.

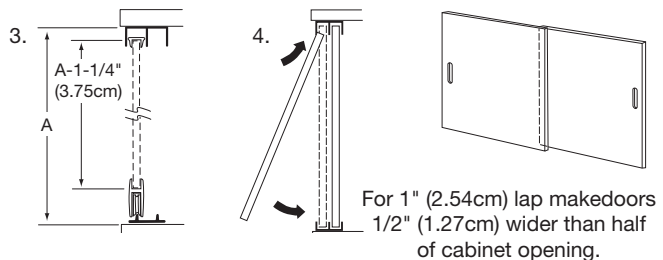

## 6. AVAILABILITY AND COST

**Availability:** Knapé & Vogt™ (KV) products are available from stocking distributors and through KV® Representatives worldwide.

**Cost:** Current pricing is available from area KV® Representatives. Please call for the nearest representative: (800) 253-1561.

## 7. WARRANTY

**Limited Lifetime Warranty:** Knapé & Vogt offers its standard Limited Lifetime Warranty to the initial purchaser of commercial products. This warranty covers defects in materials and workmanship which occur during normal use, and the remedy is limited to repair or replacement of defective products, at KV's option. Certain types of defects and damage are excluded from warranty coverage, costs and expenses are not covered, and additional restrictions apply. A copy of the Limited Lifetime Warranty, with all warranty details, limitations and disclaimers, is available on the Customer Care Connection location at [www.kv.com](http://www.kv.com) or from KV Customer Service, 2700 Oak Industrial Drive, Grand Rapids, MI 49505, (800) 253-1561.

## 8. MAINTENANCE

Metal Tracks and Sheaves for Sliding Wood Doors require no maintenance. Inspect for proper fit periodically and adjust when necessary. Replace as required or recommended by application.

## 9. TECHNICAL SERVICES

Knapé & Vogt™ and area representatives can assist with any application. For further information, or for the name of the representative nearest you, please call Knapé & Vogt™ Customer Service: (800) 253-1561 or visit our website at: [www.kv.com](http://www.kv.com).

## 10. FILING SYSTEMS

Additional product information, data sheets, application sheets, and a full catalog are available upon request from Knapé & Vogt™.

**BHMA** *Knapé & Vogt products follow the ANSI testing standards established by BHMA.*

*Knapé & Vogt reserves the right to change product specifications at any time without notice and without incurring responsibility for existing units. This information conforms to editorial style prescribed by The Construction Specifications Institute.*