

APPLICATIONS: For use in lateral files, heavy duty cabinets, and tool boxes where an interlock/anti-tilt system is used as a security locking system. Use with Accuride interlock slide models 3621 for metal or 3641 for wood applications.

Part Number 4180-0345-XE
For Use With Interlock Slide
Models 3621 and 3641

Cabinet Gang Locking System

The Gang Locking System is designed to interface with an eccentric cam lock cylinder, mounted either in the cabinet header rail or drawer front. See Figures 1, 2, and 5.

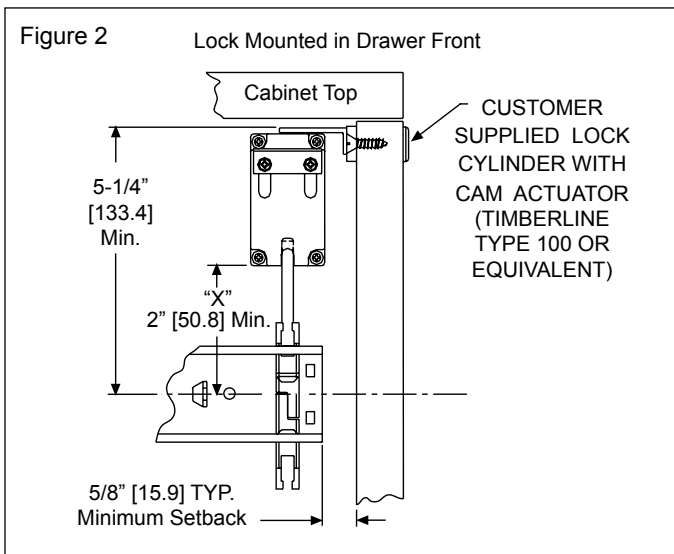
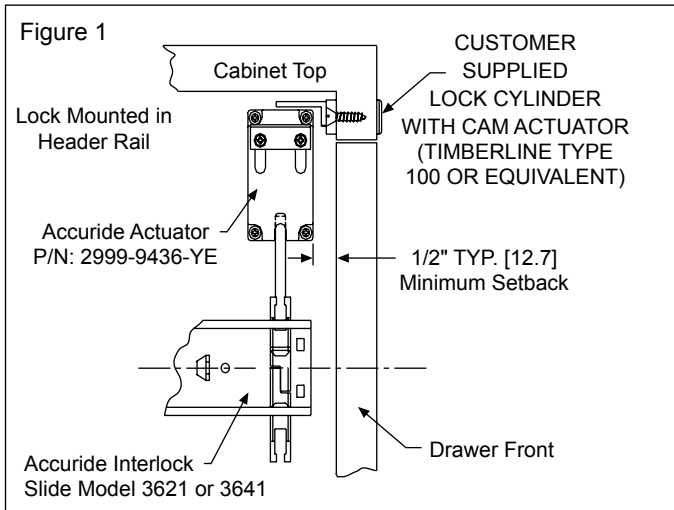

The interface actuator box requires a rod length $1/8$ " [3.2] less than the distance from the uppermost slide centerline to the bottom of the actuator. See Figure 4. The slides require $1/4$ " [6.4] diameter aluminum or steel rods 2" less than slide centerline spacing. See Figure 3. The normal ± 0.020 " tolerance on length applies. Locked position lash is directly proportional to the rods being shorter than nominal length. Lash increases as rod length decreases. The system is designed to prevent installation of rods more than 0.020 " longer than nominal.

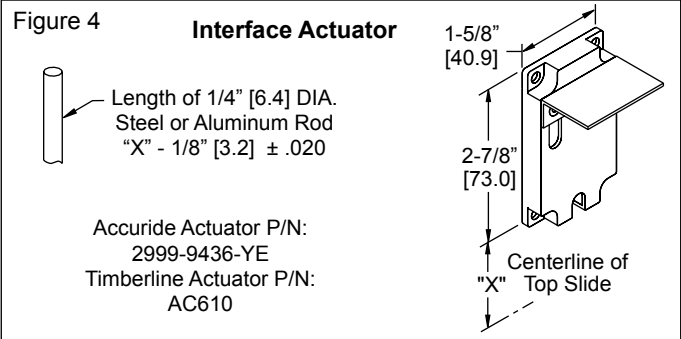
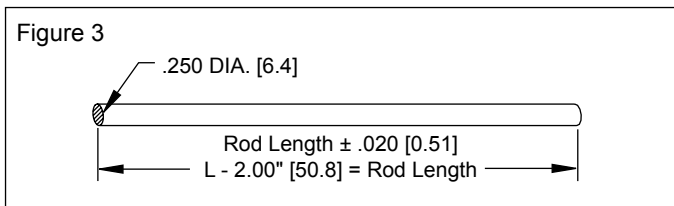

NOTE: For cabinets requiring a lock cylinder mounted in the center of the cabinet, consult Timberline for their #AC600 actuators and related hardware with flexible steel actuating cable. This cable system allows the cabinet to be locked on both sides, if required.

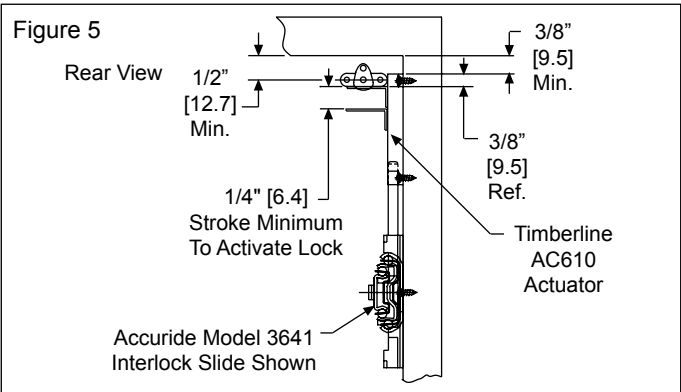

Ordering and Packaging Procedure

Part number 4180-0345-XE, Gang Locking System Interface Kit, is used with Accuride slide models 3621 (metal applications) and model 3641 (wood applications). The **customer supplied** lock cylinder can be mounted in the header rail or drawer front on either side, or both sides of the unit. For lock mounted on **one** side, order 1 kit per unit. For locks mounted on **both** sides, order 2 kits per unit.

Total Kit Required 4 Each 4180-0345-XE
 Gang Locking Kit Part Number _____

(Kit contains one Timberline Actuator #AC610 [Accuride part number 2999-9436-YE] and installation sheet.)

Note: Specifications, materials, prices, terms, and delivery are subject to change without notice.