

Richelieu

3832

Coulisse de tiroir à billes pleine extension
Full extension ball bearing drawer slide

LONGUEUR / LENGTH

- | | |
|--------------------------------------|--------------------------------------|
| <input type="checkbox"/> 12" (300mm) | |
| <input type="checkbox"/> 14" (350mm) | <input type="checkbox"/> 20" (500mm) |
| <input type="checkbox"/> 16" (400mm) | <input type="checkbox"/> 22" (550mm) |
| <input type="checkbox"/> 18" (450mm) | <input type="checkbox"/> 24" (600mm) |

Mesure en pouce approximative / Approximate inch measurement

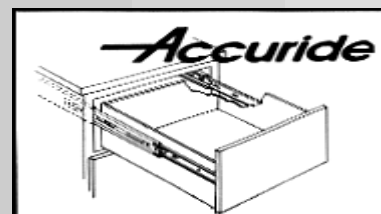

UCT38322G

INSTRUCTIONS D'ASSEMBLAGE

Assemblage du caisson sans cadre

1. Séparez les pièces coulissantes en abaissant le levier de dégagement.
2. Installez les pièces principales du caisson tel qu'indiqué à la Figure 1.
3. Vérifiez que les deux parties du caisson soient verticalement et horizontalement parallèles. Faites les ajustements nécessaires.
4. Installez la pièce du tiroir tel qu'indiqué à la Figure 2, vis-à-vis les fentes verticales.
5. Insérez la partie du caisson et fermez complètement.

FIGURE 1

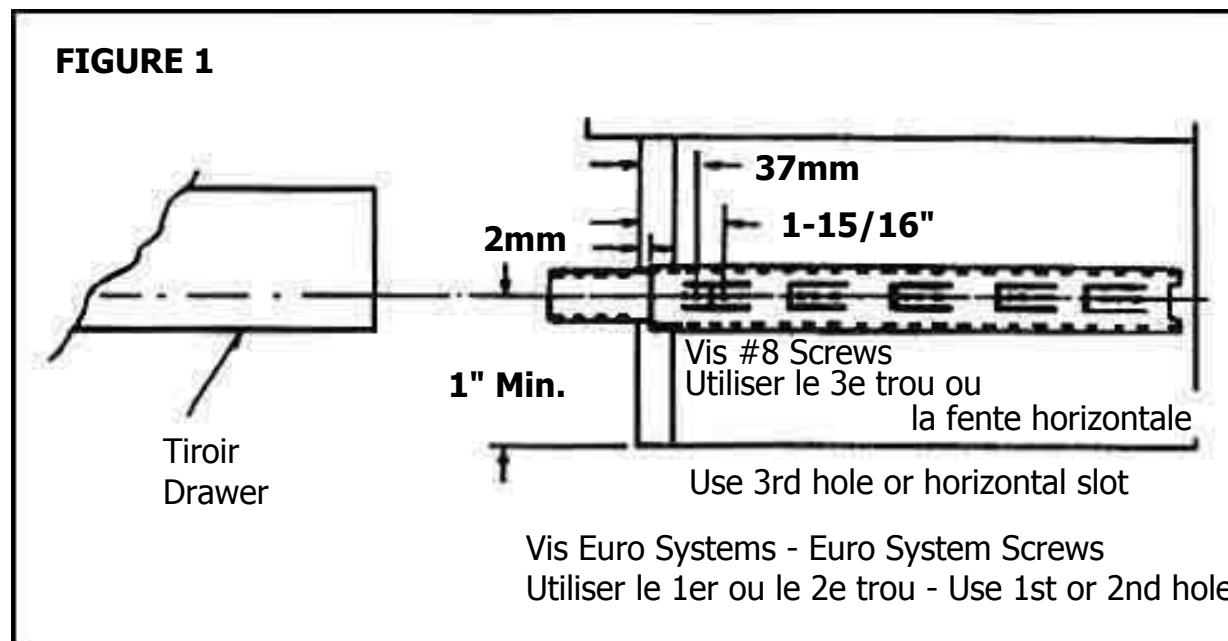

Richelieu

3832

Coulisse de tiroir à billes pleine extension
Full extension ball bearing drawer slide

LONGUEUR / LENGTH

- | | |
|--------------------------------------|--------------------------------------|
| <input type="checkbox"/> 12" (300mm) | <input type="checkbox"/> 20" (500mm) |
| <input type="checkbox"/> 14" (350mm) | <input type="checkbox"/> 22" (550mm) |
| <input type="checkbox"/> 16" (400mm) | <input type="checkbox"/> 24" (600mm) |
| <input type="checkbox"/> 18" (450mm) | |

Mesure en pouce approximative / Approximate inch measurement

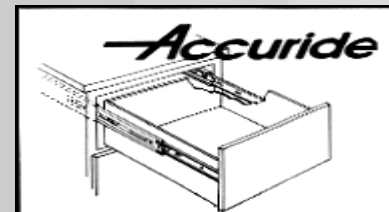

UCT38322G

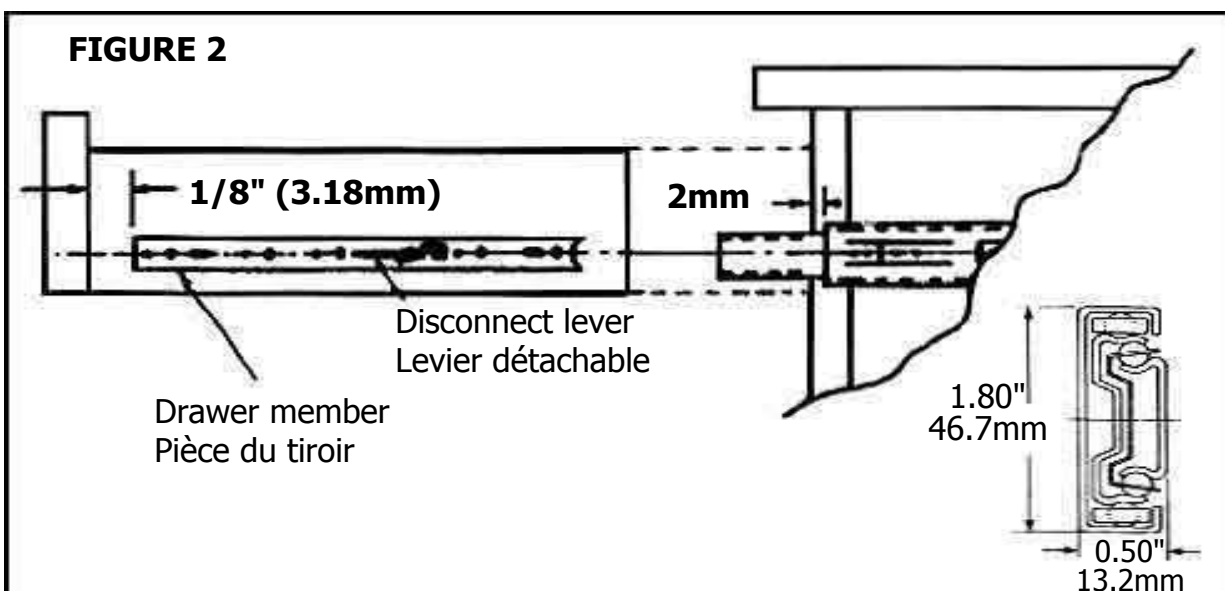

MOUNTING INSTRUCTIONS

Mounting into frameless cabinets

1. Separate slide members by depressing the lever release.
2. Install large cabinet members as shown in Figure 1.
3. Check that both cabinet members are vertically and horizontally parallel. Make necessary adjustments.
4. Install drawer member as shown in Figure 2 through vertical slots. Adjust position and install two more screws in round holes.
5. Insert drawer member and close completely.