

8 7 6 5 4 3 2 1

D

D

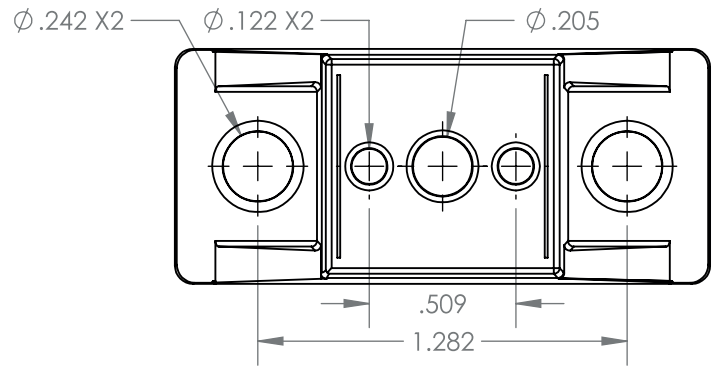

C

C

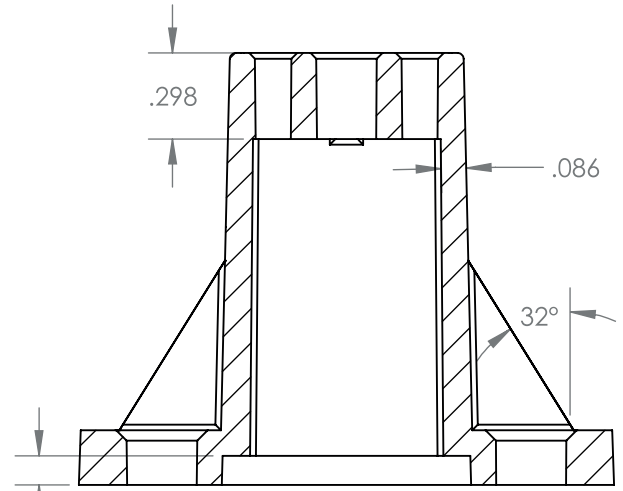

SECTION B-B

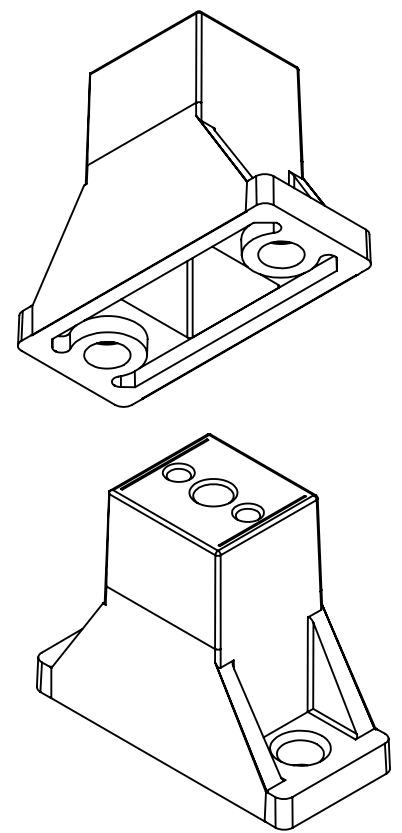
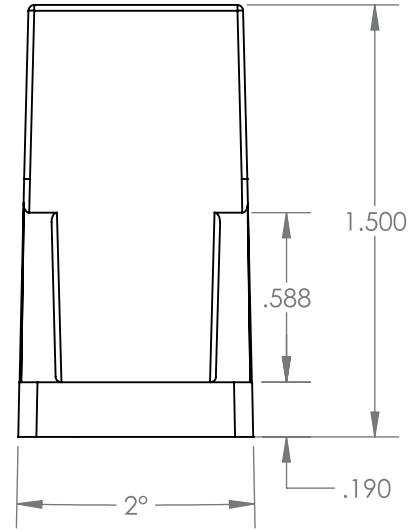

B

B

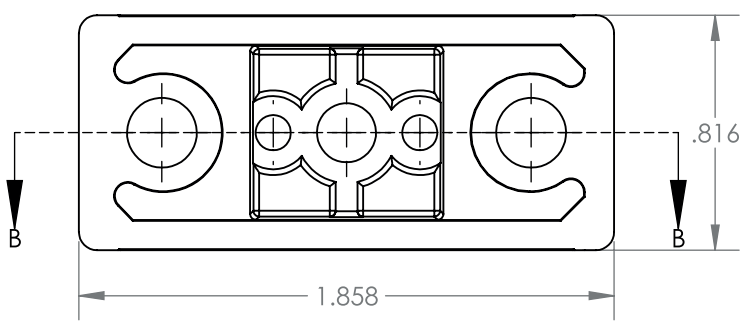

A

A

PART FILE NAME: 3675
 REVISION: P01

UNLESS OTHERWISE SPECIFIED:		
DIMENSIONS ARE IN INCHES AND MILLIMETERS [MM]. TOLERANCES:		
<u>INCHES</u>	<u>MILLIMETERS</u>	
.X: ± 0.1	[X]: $[\pm 3]$	
.XX: ± 0.03	[X.X]: $[\pm 0.8]$	
.XXX: ± 0.015	[X.XX]: $[\pm 0.38]$	
ANGULAR:		
MACHINE: $\pm 0.5^\circ$, BEND: $\pm 1.0^\circ$		
GEOMETRIC TOLERANCING PER: ASME-Y14.5-94		
MATERIAL: NYLON		
DO NOT SCALE		
SCALE: 3:2	WEIGHT: 9.93 g	SHEET 1 OF 1

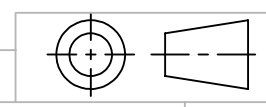

8 7 6 5 4 3 2 1